

AZTECA  GENERAL 25  
CATALOGUE

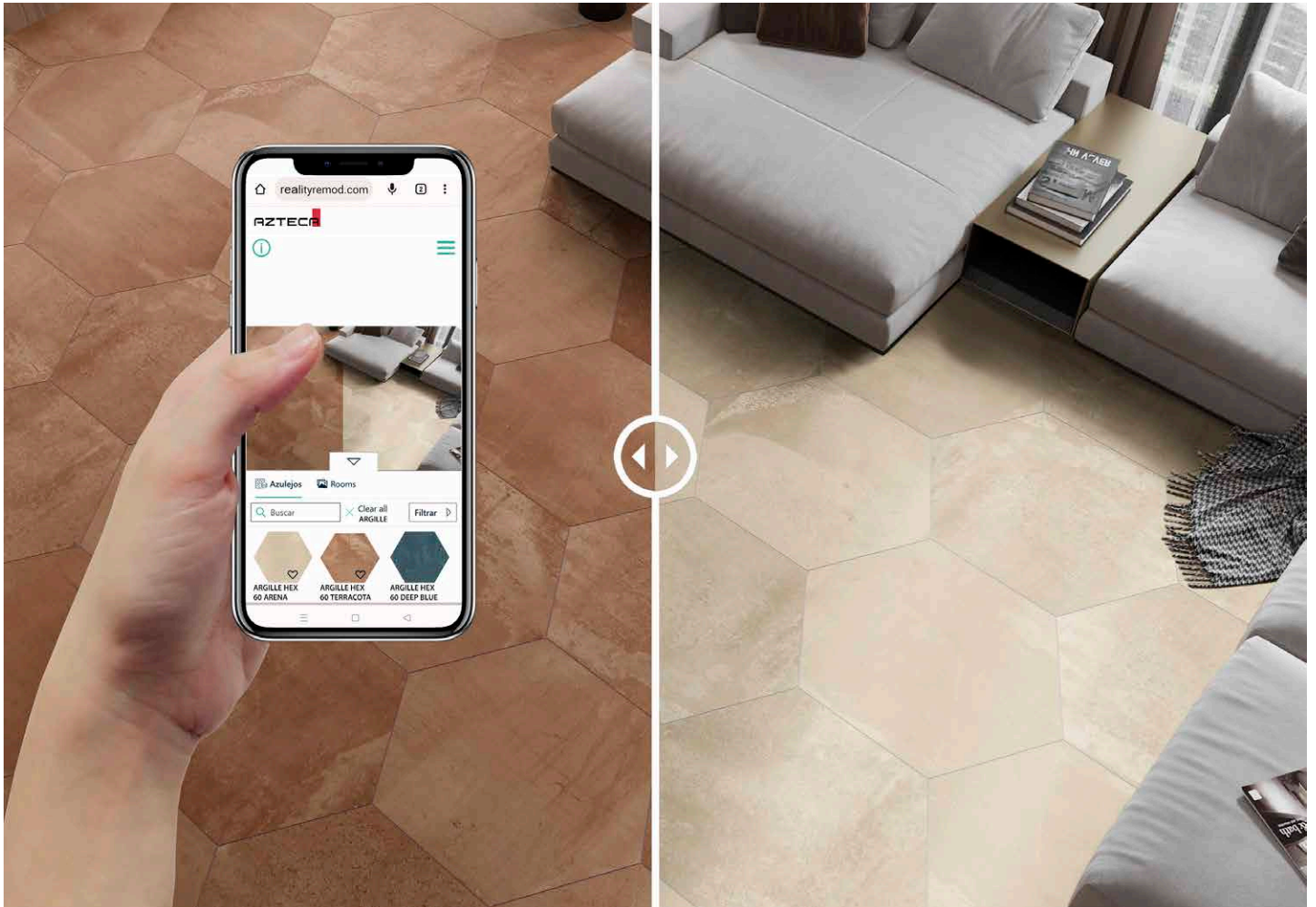

¿Personalizar tu espacio con un solo click? Ahora es posible · *Customize your space in one click? Now is possible*

**PRUEBA AHORA · TRY NOW**  
[www.realityremod.com/azteca](http://www.realityremod.com/azteca)

- Haz una foto · *Take a photo*
- Súbela · *Upload it*
- Prueba tantos diseños como quieras · *Try as many tiles as you like*



Somos una empresa dedicada a la fabricación y comercialización de soluciones de revestimiento cerámico de alto valor añadido con una gran vocación por el servicio, orientado a satisfacer las necesidades de promoción, colocación y decoración de nuestros clientes y prescriptores a nivel mundial. Queremos ser el partner de referencia para nuestros clientes, con independencia de su tamaño y localización; cuando piensen en calidad, diseños diferenciadores y soluciones cerámicas a medida de sus necesidades. 60 años de experiencia fabricando revestimientos y pavimentos cerámicos avalan hoy nuestros principales valores de empresa.

*We are a company dedicated to the manufacture and commercialization of high value-added ceramic tile solutions with service as our main aim, fully directed to the needs of our clients and consultants worldwide regarding sampling, setting tips, decorating needs; and any further issue that may be posed. Our primary goal is to be considered as a lead partner by our clients, regardless of their size and location; when they think of quality, differentiating designs and ceramic solutions tailored to their needs. 60 years of experience manufacturing ceramic floor and wall tiles, and we still uphold our principal company values.*





5
6

BALI

collection

PORCELÁNICO · PORCELAIN | RECTIFICADO · RECTIFIED | DESTONIFICADO V2 · DESTONIFIED V2

3  
 60x120 cm  
23,6"x47,2"

7  
 60x60 cm  
23,6"x23,6"

8  
 30x30 cm  
11,8"x11,8"

FORMATOS DISPONIBLES AVAILABLE FORMATS	ACABADO NATURAL NATURAL FINISH	ACABADO ANTIDESLIZANTE SLIP RESISTANCE FINISH	ACABADO LAPADO BRILLO GLOSSY LAPATTO FINISH
60x120 cm - 23,6"x47,2"	BALI 120   B85	BALI DRY 120   B86	BALI LUX 120   B88
60x60 cm - 23,6"x23,6"	BALI 60   B35	BALI DRY 60   B36	BALI LUX 60   B37
30x30 cm - 11,8"x11,8"	MOSAICO BALI T5   P70	---	MOSAICO BALI LUX T5   P60

TAMAÑO DEL LIENZO: 133x420 cm - GRAPHIC CHART SIZE: 52,4"x165,4"

1  
2 E  
 TAUPE

9  
10 E  
 WHITE

12  
14 E  
 GREY

BALI collection | CEMENTO · CONCRETE

1 Colores disponibles.  
Available colors.

2 Grupo de uso (consultar en página 328).  
Use group (see page 329).

3 Formatos disponibles en las series.  
Size options available in the series.

4 Características de las series: tipo de producto (pasta roja, pasta blanca, porcelánico),  
rectificado y destonificación.  
Series features: product type (red body, white body, porcelain), rectified and shade variation.

5 Imagen de muestra de la gráfica de la colección.  
Sample image of the collection chart.

6 Escala de la gráfica.  
Graphic scale.

7 Acabados disponibles.  
Available finishes.

8 Iconos descriptivos de cada acabado disponible (consultar iconos en la página 336).  
Descriptive icons of each available finish (see icons on page 336).

9 Referencias disponibles mostradas en una tabla según formato y acabado.  
Available references shown in a table according to format and finish.

10 Iconos específicos de las piezas.  
Specific icons of pieces.

11 Nombre de la colección.  
Collection name.

12 Familia a la que pertenece la colección.  
Family to which the collection belongs.

13 Imagen de ejemplo de aplicación de la colección.  
Example image of application of the collection.

14 Relación de las referencias que aparecen en la imagen.  
List of references that appear in the image.

# ÍNDICE POR FORMATOS | INDEX BY FORMATS



PASTA BLANCA  
WHITE BODY

		R120	R90	R3060 RECT.	5x50	6x25	5x25
		40x120 cm 15,7"x47,2"	30x90 cm 11,8"x35,4"	30x60 cm 11,8"x23,6"	5x50 cm 2"x19,7"	6,2x25 cm 2,4"x9,8"	5x25 cm 2"x9,8"
AMAZONAS	214 - 217						
ANETO	100 - 103						
ANGORA	74 - 77						
ARGILLE	16 - 19						
ARMONY	104 - 105						
AURA	300 - 303						
BALI	20 - 29						
BARRICA	186 - 189						
BELLVER	106 - 111						
BROOKLYN	212 - 215						
CALACATTA	218 - 223						
CEMENT	30 - 39						
CERVINO	224 - 227						
COLORS	304 - 307						
COSMOS	156 - 157						
CRISTALLO	228 - 233						
DA VINCI	234 - 235						
DELHI	190 - 193						
DOMINO	116 - 117						
DUBAI	236 - 237						
ELEKTRA	158 - 161						
ESSENZA	308 - 311						
FAME	162 - 165						
FONTANA	238 - 239						
GROUND	118 - 121						
HARLEY	166 - 167						
HERITAGE	78 - 79						
JASPER	240 - 241						
KAI	40 - 47						
KALEIDOSCOPE	80 - 83   312 - 315						
LAMEO	194 - 197						
LEGNO	198 - 203						
MACCHIA VECCHIA	242 - 245						
MARBLEFULL							
BOMBAY	246 - 249						
INVISIBLE	250 - 253						
PATAGONIA	254 - 257						
MIRROR	168 - 169						
NAGOYA	258 - 263						
NAIROBI	204 - 207						
NEBRASKA	208 - 211						
ONYX	264 - 267						
ORION	170 - 173						
PARADOX	268 - 273						
PASSION	274 - 275						
PERLA VENATA	276 - 281						
PORTOPETRO	122 - 127						
SAN FRANCISCO	48 - 53						
SAHARA	174 - 177						
SANTANYI	128 - 131						
SEASTONE	132 - 135						
SENSE	84 - 89						
SHELLSTONE	136 - 143						
SMART	178 - 179						
STONEAGE	144 - 149						
STONECRETE							
DISTRICT	54 - 57						
STREET	58 - 63						
STUDIO	64 - 71						
SYNTHESIS	180 - 183						
TOSCANA	152 - 153						
TURQUETA	316 - 319						
TRAVERTINE							
LACIO	282 - 285						
TIVOLI	286 - 289						
VIENA	90 - 91						
VICHY	290 - 293						
VULCANO	294 - 297						
WHITE	92 - 97						



PORCELÁNICO  
PORCELAIN

		120	9090	60x120	30	20	60	HEX60	3060	15x60	20x20	15x15	5x15
		120x120 cm 47,2"x47,2"	90x90 cm 35,4"x35,4"	60x120 cm 23,6"x47,2"	30x120 cm 11,8"x47,2"	19,4x120 cm 7,6"x47,2"	60x60 cm 23,6"x23,6"	52x60 cm 20,5"x23,6"	30x60 cm 11,8"x23,6"	14,7x60 cm 5,8"x23,6"	20x20 cm 7,9"x7,9"	15x15 cm 5,9"x5,9"	5x15 cm 2"x5,9"
AMAZONAS	214 - 217												
ANETO	100 - 103												
ANGORA	74 - 77												
ARGILLE	16 - 19												
ARMONY	104 - 105												
AURA	300 - 303												
BALI	20 - 29												
BARRICA	186 - 189												
BELLVER	106 - 111												
BROOKLYN	212 - 215												
CALACATTA	218 - 223												
CEMENT	30 - 39												
CERVINO	224 - 227												
COLORS	304 - 307												
COSMOS	156 - 157												
CRISTALLO	228 - 233												
DA VINCI	234 - 235												
DELHI	190 - 193												
DOMINO	116 - 117												
DUBAI	236 - 237												
ELEKTRA	158 - 161												
ESSENZA	308 - 311												
FAME	162 - 165												
FONTANA	238 - 239												
GROUND	118 - 121												
HARLEY	166 - 167												
HERITAGE	78 - 79												
JASPER	240 - 241												
KAI	40 - 47												
KALEIDOSCOPE	80 - 83												
LAMEO	194 - 197												
LEGNO	198 - 203												
MACCHIA VECCHIA	242 - 245												
MARBLEFULL													
BOMBAY	246 - 249												
INVISIBLE	250 - 253												
PATAGONIA	254 - 257												
MIRROR	168 - 169												
NAGOYA	258 - 263												
NAIROBI	204 - 207												
NEBRASKA	208 - 211												
ONYX	264 - 267												
ORION	170 - 173												
PARADOX	268 - 273												
PASSION	274 - 275												
PERLA VENATA	276 - 281												
PORTOPETRO	122 - 127												
SAN FRANCISCO	48 - 53												
SAHARA	174 - 177												
SANTANYI	128 - 131												
SEASTONE	132 - 135												
SENSE	84 - 89												
SHELLSTONE	136 - 143												
SMART	178 - 179												
STONEAGE	144 - 149												
STONECRETE													
DISTRICT	54 - 57												
STREET	58 - 63												
STUDIO	64 - 71												
SYNTHESIS	180 - 183												
TOSCANA	152 - 153												
TURQUETA	316 - 319												
TRAVERTINE													
LACIO	282 - 285												
TIVOLI	286 - 289												
VIENA	90 - 91												
VICHY	290 - 293												
VULCANO	294 - 297												
WHITE	92 - 97												



ÍNDICE POR TIPOLOGÍA DE PRODUCTO | INDEX BY PRODUCT TYPE



CEMENTO | CONCRETE · COTTO

ARGILLE · NEW	16 - 19
BALI	20 - 29
CEMENT · NEW	30 - 39
KAI	40 - 47
SAN FRANCISCO	48 - 53
STONECRETE · DISTRICT	54 - 57
STONECRETE · STREET	58 - 63
STUDIO · NEW	64 - 71



COLOR | COLOR

ANGORA · NEW	74 - 77
HERITAGE	78 - 79
KALEIDOSCOPE · NEW	80 - 83
SENSE	84 - 89
VIENA	90 - 91
WHITE · NEW	92 - 97



PIEDRA | STONE

ANETO	100 - 103
ARMONY	104 - 105
BELLVER	106 - 111
BROOKLYN	112 - 115
DOMINO	116 - 117
GROUND	118 - 121
PORTOPETRO · NEW	122 - 127
SANTANYI · NEW	128 - 131
SEASTONE	132 - 135
SHELLSTONE · NEW	136 - 143
STONEAGE	144 - 149
TOSCANA	150 - 153



METAL | METAL

COSMOS	156 - 157
ELEKTRA	158 - 161
FAME	162 - 165
HARLEY	166 - 167
MIRROR · NEW	168 - 169
ORION	170 - 173
SAHARA · NEW	174 - 177
SMART	178 - 179
SYNTHESIS	180 - 183



MADERA | WOOD

BARRICA	186 - 189
DEHLI	190 - 193
LAMEO · NEW	194 - 197
LEGNO	198 - 203
NAIROBI	204 - 207
NEBRASKA · NEW	208 - 211



MÁRMOL | MARBLE

AMAZONAS · NEW	214 - 217
CALACATTA · NEW	218 - 223
CERVINO	224 - 227
CRISTALLO · NEW	228 - 233
DA VINCI	234 - 235
DUBAI	236 - 237
FONTANA	238 - 239
JASPER	240 - 241
MACCHIA VECCHIA	242 - 245
MARBLEFULL · BOMBAY	246 - 249
MARBLEFULL · INVISIBLE	250 - 253
MARBLEFULL · PATAGONIA	254 - 257
NAGOYA	258 - 263
ONYX	264 - 267
PARADOX · NEW	268 - 273
PASSION	274 - 275
PERLA VENATA · NEW	276 - 281
TRAVERTINE · LACIO	282 - 285
TRAVERTINE · TIVOLI	286 - 289
VICHY · NEW	290 - 293
VULCANO	294 - 297



ONZA | SMALL SIZES





AURA · NEW	300 - 303
COLORS · NEW	304 - 307
ESSENZA · NEW	308 - 311
KALEIDOSCOPE · NEW	312 - 315
TURQUETA · NEW	316 - 319







**ÍNDICE | INDEX**  
**CLASIFICACIÓN ANTIDESLIZANTES | ANTISLIPING CLASIFICATION**

COLECCIÓN COLLECTION	PÁGINA PAGE	ARTÍCULO ARTICLE					
AMAZONAS	214-217	AMAZONAS 9090   120	1		>0,42		
ANETO	100-103	ANETO SOFT 120   60   3060	2	9	>0,42		
		ANETO DRY 120   60	3	10	>0,61		
ARGILLE	16-19	ARGILLE 60   HEX60	3		>0,61		
BALI	20-29	BALI 120   60	2	10	>0,42	>36	
		BALI DRY 120   60	3	11	>0,42	>36	A+B+C
BARRICA	186-189	BARRICA 20   30	2	10	>0,42		
		BARRICA DRY 20   30	3	11	>0,42	>36	
BELLVER	106-111	BELLVER 9090   120   60   3060	1				
		BELLVER DRY 9090   120   60   3060	3	11	>0,61		
CALACATTA	218-223	CALACATTA NAT 120x120   9090   120   60   HEX60   3060	1	9			
		CALACATTA DRY 9090   120   60   HEX60   3060	3		>0,42	>36	
CEMENT	30-39	CEMENT 9090   120   60	1		>0,42		
		CEMENT DRY 9090   120   60	3		>0,61	>36	
DELHI	190-193	DELHI 20	2	10	>0,42	>36	
DOMINO	116-117	DOMINO SOFT 120	1	9	>0,42		
DUBAI	236-237	DUBAI 120   60	1		>0,42		
ELEKTRA	158-161	ELEKTRA LUX 120   60   3060			>0,42		
HARLEY	166-167	HARLEY LUX 60   3060		9			
KAI	40-47	KAI 9090   120   60   HEX60	1				
LEGNO	198-203	LEGNO 30   20	1				
		LEGNO DRY 30   20	3		>0,42	>36	
MACCHIA VECCHIA	242-245	MACCHIA VECCHIA NAT 120   60   3060	1	9			
MARBLEFULL - PATAGONIA	254-257	PATAGONIA 120   60	1				
NAGOYA	258-263	NAGOYA 120   60   3060   15x60	1	9	>0,42		
NAIROBI	204-207	NAIROBI 20	1	9	>0,42		
		NAIROBI DRY 20	3	11	>0,61	>36	A+B+C
NEBRASKA	208-211	NEBRASKA 20   30	1				
		NEBRASKA DRY 20   30	3		>0,42		
PASSION	274-275	PASION LUX 120   60   3060			>0,42		
PERLA VENATA	276-281	PERLA VENATA 9090   120   60   3060	1		>0,42		
SAN FRANCISCO	48-53	SAN FRANCISCO 120   60   HEX60   3060	1	10	>0,42		
		SAN FRANCISCO DRY 120   60   3060	3	11	>0,61	>36	
SANTANYI	128-131	SANTANYI 9090   120   60	1				
		SANTANYI C2 9090   120   60	2				
		SANTANYI DRY 9090   120   60	3		>0,61		
SEASTONE	132-135	SEASTONE 120   60	1	9			
		SEASTONE DRY 120   60	3	11	>0,61		A+B+C
SHELLSTONE	136-143	SHELLSTONE 120x120   9090   120   60   3060	1		>0,42		
		SHELLSTONE DRY 120x120   9090   120   60   3060	3	11	>0,61	>36	
SMART	178-179	SMART LUX 60   3060		10			
STONEAGE	144-149	STONEAGE 120   60   3060	2	10	>0,42	>36	
		STONEAGE DRY 120   60   3060	3	11	>0,42	>36	A+B+C
STONECRETE - DISTRICT	54-57	DISTRICT 9090   120   60   3060	1				
		DISTRICT DRY 9090   120   60	3	11	>0,42		A+B
STONECRETE - STREET	58-63	STREET 9090   120   60   3060	1				
		STREET DRY 9090   120   60	3	11	>0,42		A+B
STUDIO	64-71	STUDIO 120x120   9090   120   60   3060	1	9			
		STUDIO DRY 120x120   9090   120   60   3060	3	11	>0,61	>36	A+B+C
SYNTHESIS	180-183	SYNTHESIS 120   60   3060	1	9	>0,42		
TOSCANA	150-153	TOSCANA 9090   60	1	9	>0,42		
		TOSCANA DRY 9090	3	11	>0,61	>36	A+B+C
TRAVERTINE - LACIO	282-285	LACIO DRY 120	3	11	>0,61		
TRAVERTINE - TIVOLI	286-289	TIVOLI DRY 120	3	11	>0,61		

ÍNDICE ALFABÉTICO | ALPHABETIC INDEX

	<b>A</b>						
215	AMAZONAS LUX 120 FOREST, RAIN, RIVER, WILD	219	CALACATTA GOLD, SILVER NAT 120	25	DECORADO BLOOM R90 TAUPE, WHITE	239	FONTANA LUX 120 CREAM, BROWN, ICE, VISON
215	AMAZONAS 120 FOREST, RAIN, RIVER, WILD	219	CALACATTA GOLD NAT 120X120	25	DECORADO BRUSH R90	239	FONTANA LUX 60 CREAM, BROWN, ICE, VISON
215	AMAZONAS 9090 FOREST, RAIN, RIVER, WILD	219	CALACATTA GOLD, SILVER NAT 3060	25	DECORADO BRUSH R90 GOLD, SILVER		<b>G</b>
101	ANETO DRY 120 DARK GREY, GREY, SAND	219	CALACATTA GOLD, SILVER NAT 60	35, 141	DECORADO CANDY R90	119	GROUND LUX 60 GREY, SNOW, TERRA
101	ANETO DRY 60 DARK GREY, GREY, SAND	219	CALACATTA GOLD, SILVER NAT 9090	35	DECORADO CHLOE R90	121	GROUND R3060 RECT GREY, SNOW, TERRA
103	ANETO R3060R GREY, SAND	219	CALACATTA GOLD, SILVER NAT HEX60	35, 141	DECORADO COZY R90	121	GROUND R90 GAP GREY, SNOW, TERRA
103	ANETO R3060R WALL GREY, SAND	219	CALACATTA GOLD, SILVER NAT HEX60	159	DECORADO ELEKTRA 120 GOLD, SILVER	121	GROUND R90 GREY, SNOW, TERRA
101	ANETO SOFT 120 DARK GREY, GREY, SAND	223	CALACATTA GOLD R120 BOB GLOSSY	159	DECORADO ELEKTRA 3060 GOLD, SILVER		<b>H</b>
101	ANETO SOFT 3060 DARK GREY, GREY, SAND	223	CALACATTA GOLD R120 GLOSSY	159	DECORADO ELEKTRA 60 GOLD, SILVER	167	HARLEY LUX 3060 BLACK, GRAPHITE, SUPERWHITE
101	ANETO SOFT 60 DARK GREY, GREY, SAND	223	CALACATTA GOLD R120 MATT	308	DECORADO FLOWER 15x15 ARTIC, BLUE, BREEZE, CLAY, SIENA, WHITE	167	HARLEY LUX 60 BLACK, GRAPHITE, SUPERWHITE
75	ANGORA R90 GREY, SAND, WHITE	223	CALACATTA GOLD R120 TOP MATT	121	DECORADO GUESS R3060 RECT GREY, TERRA	79	HERITAGE R90 GREEN, BLUE, WHITE
17	ARGILLE 60 DEEP BLUE, AQUAMARINE, ARENA, TEJA, TERRACOTA	223	CALACATTA GOLD, SILVER R3060 RECT GLOSSY	121	DECORADO GUESS R90 GREY, TERRA		<b>I</b>
17	ARGILLE HEX60 DEEP BLUE, AQUAMARINE, ARENA, TEJA, TERRACOTA	223	CALACATTA GOLD, SILVER R3060 RECT MATT	251	DECORADO INVICTUS NAT 120 WHITE	251	INVISIBLE LUX 120 WHITE
17	ARGILLE HEX60 RHOMBOID DEEP BLUE, AQUAMARINE, ARENA, TEJA, TERRACOTA	223	CALACATTA GOLD, SILVER R3060 RECT VALS GLOSSY	45	DECORADO KAI 120 ASH, GRAPHITE, GREIGE, PEARL	251	INVISIBLE LUX 3060 WHITE
105	ARMONY R90 BONE, SNOW	223	CALACATTA GOLD, SILVER R3060 RECT WALL MATT	43	DECORADO KAI 9090 ASH, GRAPHITE, GREIGE, PEARL	251	INVISIBLE LUX 60 WHITE
105	ARMONY R90 DUNES BONE, SNOW	223	CALACATTA GOLD, SILVER R90 BOB GLOSSY	44	DECORADO KAI HEX60 ASH, GRAPHITE, GREIGE, PEARL	251	INVISIBLE NAT 120 WHITE
300	AURA 6,2x25 CLAY, CORAL, GARNET, GRAPHITE, GREY, SAGE, WHITE	223	CALACATTA GOLD, SILVER R90 GLOSSY	47	DECORADO KAROL R120 GREIGE	251	INVISIBLE NAT 3060 WHITE
	<b>B</b>	223	CALACATTA GOLD, SILVER R90 MATT	47	DECORADO KRONOS R120 PEARL	251	INVISIBLE NAT 60 WHITE
21	BALI 120 WHITE, GREY, TAUPE	223	CALACATTA GOLD, SILVER R90 TOP MATT	195	DECORADO LAMEO R120 ROVERE		<b>J</b>
21	BALI 60 WHITE, GREY, TAUPE	31	CEMENT 120 GREY, PEARL, SAND, WHITE	293	DECORADO LAURIER R90 CREMA, GRIS	241	JASPER LUX 60 BEIGE, GREY
21	BALI DRY 120 WHITE, GREY, TAUPE	31	CEMENT 60 GREY, PEARL, SAND, WHITE	285	DECORADO LILY SOFT 120 ARENA, IVORY		<b>K</b>
21	BALI DRY 60 WHITE, GREY, TAUPE	31	CEMENT 9090 GREY, PEARL, SAND, WHITE	169	DECORADO MIRROR R120 GOLD, SILVER	41	KAI 120 ASH, GRAPHITE, GREIGE, PEARL
21	BALI LUX 120 WHITE, GREY, TAUPE	31	CEMENT DRY 120 GREY, PEARL, SAND, WHITE	25, 245	DECORADO PALM R90 WHITE MATT	41	KAI 60 ASH, GRAPHITE, GREIGE, PEARL
21	BALI LUX 60 WHITE, GREY, TAUPE	31	CEMENT DRY 60 GREY, PEARL, SAND, WHITE	308	DECORADO RUSTIC 15x15 ARITC, BLUE, BREEZE, CLAY, SIENA, WHITE	41	KAI 9090 ASH, GRAPHITE, GREIGE, PEARL
25	BALI R90 WHITE, GREY, TAUPE	31	CEMENT DRY 9090 GREY, PEARL, SAND, WHITE	177	DECORADO SAHARA 120 GOLD, SILVER	41	KAI HEX60 ASH, GRAPHITE, GREIGE, PEARL
25	BALI R90 TRICOT WHITE, GREY, TAUPE	35	CEMENT R90 CODE WHITE, SAND	51	DECORADO SAN FRANCISCO HEX60 WHITE	47	KAI R120 GREIGE, PEARL
187	BARRICA 20 BONE, MIEL, NUEZ, CHOCOLATE, GRIS	35	CEMENT R90 GREY, PEARL, WHITE, SAND	85	DECORADO SENDAI R90 WHITE	81	KALEIDOSCOPE 120 CREAM, OFF WHITE, TAUPE, WHITE
187	BARRICA 30 BONE, MIEL, NUEZ, CHOCOLATE, GRIS	35	CEMENT R90 GREY, PEARL, WHITE, SAND	123	DECORADO SPINE R90 NUDE	312	KALEIDOSCOPE 20x20 CREAM, NUDE, OFF WHITE, SAGE, TAUPE, TERRACOTA, WHITE
187	BARRICA DRY 20 GRIS, MIEL, NUEZ	225	CERVINO LUX 120 WHITE, BLACK	85	DECORADO STRIPE R90 GREY, TERRA	81	KALEIDOSCOPE MOSAIC BRICK ORO TAUPE, WHITE
187	BARRICA DRY 30 GRIS, MIEL, NUEZ	225	CERVINO LUX 3060 WHITE, BLACK	69	DECORADO STUDIO R90	81	KALEIDOSCOPE MOSAIC HEX TILIA TAUPE, WHITE
93	BEAUTY R90 WHITE	209	CHEVRON NEBRASKA 60 MIEL, NOGAL, ROBLE	123	DECORADO SUAU R90 SAND, WHITE	95	KEYWEST R90 WHITE
107	BELLVER 120 DARK GREY, GREIGE, GREY, IVORY, SAND	304	COLORS 5x25 GLOSSY BLACK, BLUE, CREAM, DARK GREY, GREEN, GREY, NAVY, TEJA, WHITE	69	DECORADO SYDNEY R3060 RECT.		<b>L</b>
107	BELLVER 3060 DARK GREY, GREIGE, GREY, IVORY, SAND	304	COLORS 5x25 MATT BLACK, BLUE, CREAM, DARK GREY, GREEN, GREY, NAVY, TEJA, WHITE	69	DECORADO SYDNEY R90	283	LACIO DRY 120 ARENA, IVORY
107	BELLVER 60 DARK GREY, GREIGE, GREY, IVORY, SAND	305	COLORS 5x50 GLOSSY BLACK, BLUE, CREAM, DARK GREY, GREEN, GREY, NAVY, TEJA, WHITE	183	DECORADO SYNCRO R90 BLACK, GREY, WHITE	283	LACIO MOSAIC BRICK AGATA IVORY
107	BELLVER 9090 DARK GREY, GREIGE, GREY, IVORY, SAND	305	COLORS 5x50 MATT BLACK, BLUE, CREAM, DARK GREY, GREEN, GREY, NAVY, TEJA, WHITE	81	DECORADO TILIA 120 TAUPE, WHITE	283	LACIO SOFT 120 ARENA, IVORY
109	BELLVER 120 PLANE DARK GREY, GREIGE, GREY, IVORY, SAND	157	COSMOS LUX 3060 BLANCO, BEIGE, NEGRO, ÓXIDO	91	DECORADO VIENA R120 WHITE	283	LACIO SOFT 3060 ARENA, IVORY
111	BELLVER 120 BLOSSOM GREY, IVORY, SAND	157	COSMOS LUX 60 BLANCO, BEIGE, NEGRO, ÓXIDO	191	DELHI 20 ALMOND, ASH, BONE, CHOCOLATE, IVORY	283	LACIO SOFT 60 ARENA, IVORY
107	BELLVER DRY 120 DARK GREY, GREIGE, GREY, IVORY, SAND	229	CRISTALLO 120 AVORIO, BIANCO, GRIGIO, NERO	55	DISTRICT 120 ASH, SAND, WHITE	199	LEGNO 20 BETULLA, FAGGIO, ROVERE, NOCE
107	BELLVER DRY 3060 DARK GREY, GREIGE, GREY, IVORY, SAND	229	CRISTALLO 3060 AVORIO, BIANCO, GRIGIO, NERO	55	DISTRICT 3060 ASH, SAND, WHITE	199	LEGNO 30 BETULLA, FAGGIO, ROVERE, NOCE
107	BELLVER DRY 60 DARK GREY, GREIGE, GREY, IVORY, SAND	229	CRISTALLO 60 AVORIO, BIANCO, GRIGIO, NERO	55	DISTRICT 60 ASH, SAND, WHITE	199	LEGNO DRY 20 BETULLA, FAGGIO, ROVERE, NOCE
107	BELLVER DRY 9090 DARK GREY, GREIGE, GREY, IVORY, SAND	229	CRISTALLO 9090 AVORIO, BIANCO, GRIGIO, NERO	55	DISTRICT 9090 ASH, SAND, WHITE	199	LEGNO DRY 30 BETULLA, FAGGIO, ROVERE, NOCE
247	BOMBAY LUX 120	229	CRISTALLO LUX 120 AVORIO, BIANCO, GRIGIO, NERO	55	DISTRICT DRY 120 ASH, SAND	203	LEGNO R90 TRAIL BETULLA, FAGGIO, ROVERE
247	BOMBAY LUX 60	229	CRISTALLO LUX 3060 AVORIO, BIANCO, GRIGIO, NERO	55	DISTRICT DRY 60 ASH, SAND	225, 245	267 LISTELO 90 FRAME ACERO, COBRE
113	BROOKLYN LUX 120 CREAM, GREY, ICE		<b>D</b>	117	DOMINO SOFT 120 BLACK, WHITE		<b>M</b>
113	BROOKLYN LUX 60 CREAM, GREY, ICE	235	DA VINCI LUX 120 WHITE	237	DUBAI 120 ICE, GREY, TAUPE, GRAPHITE	243	MACCHIA VECCHIA LUX 120 GOLD, SILVER
113	BROOKLYN LUX 9090 CREAM, ICE	235	DA VINCI LUX 3060 WHITE	237	DUBAI 60 ICE, GREY, TAUPE, GRAPHITE	243	MACCHIA VECCHIA LUX 3060 GOLD
	<b>C</b>	235	DA VINCI LUX 60 WHITE	237	DUBAI LUX 120 ICE, GREY, TAUPE, GRAPHITE	243	MACCHIA VECCHIA LUX 60 GOLD
219	CALACATTA GOLD, SILVER DRY 120	235	DA VINCI NAT 120 WHITE	237	DUBAI LUX 60 ICE, GREY, TAUPE, GRAPHITE	243	MACCHIA VECCHIA NAT 120 GOLD, SILVER
219	CALACATTA GOLD, SILVER DRY 3060	25	DECORADO 2 GARDEN R90 WHITE		<b>E</b>	243	MACCHIA VECCHIA NAT 3060 GOLD
219	CALACATTA GOLD, SILVER DRY 60	231	DECORADO 2 HABANA 120 AVORIO-GOLD, BIANCO-GOLD, GRIGIO-SILVER, NERO-GOLD, NERO-SILVER	159	ELEKTRA LUX 120 BLACK, GRAPHITE, SUPERWHITE	243	MACCHIA VECCHIA NAT 60 GOLD
219	CALACATTA GOLD, SILVER DRY 9090	279	DECORADO 2 VICTORY 120 BLANCO-GOLD, CREMA-GOLD, GRIS-SILVER, NEGRO-SILVER	159	ELEKTRA LUX 3060 BLACK, GRAPHITE, SUPERWHITE	245	MACCHIA VECCHIA R90 GOLD MATT, SILVER MATT
219	CALACATTA GOLD, SILVER DRY HEX60	75	DECORADO ALANI R90 WHITE	159	ELEKTRA LUX 60 BLACK, GRAPHITE, SUPERWHITE	17	MOSAICO ARGILLE CROSS ARENA-TERRACOTA
219	CALACATTA GOLD, SILVER LUX 120	312	DECORADO AQUARELLE 20x20 SAGE, WARM	308	ESSENZA 15x15 ARTIC, BLUE, BREEZE, CLAY, SIENA, WHITE	21	MOSAICO BALI LUX T5 WHITE, GREY, TAUPE
219	CALACATTA GOLD, SILVER LUX 3060	18	DECORADO ARGILLE HEX60 ARENA, TEJA, TERRACOTA		<b>F</b>	107	MOSAICO BALI T5 WHITE, GREY, TAUPE
219	CALACATTA GOLD, SILVER LUX 60	300	DECORADO AURA 6,2x25 CORAL, SAGE	163	FAME LUX 120 BLACK, WHITE	107	MOSAICO BELLVER T5 DARK GREY, GREIGE, GREY, IVORY, SAND
219	CALACATTA GOLD, SILVER LUX 9090	75	DECORADO AZAI R90 GREY, SAND, WHITE	163	FAME LUX 3060 BLACK, WHITE	107	MOSAICO BELLVER MURETTO DARK GREY, GREIGE, GREY, IVORY, SAND
		25	DECORADO BELA R90	163	FAME LUX 60 BLACK, WHITE	219	MOSAICO CALACATTA GOLD, SILVER NAT T5
						219	MOSAICO CALACATTA GOLD, SILVER LUX T5



31 MOSAICO CEMENT T5 WHITE, SAND, GREY, PEARL  
 225 MOSAICO CERVINO LUX PICKET BLACK, WHITE, MIX  
 225 MOSAICO CERVINO LUX T5 WHITE, BLACK  
 157 MOSAICO COSMOS LUX 30 NEGRO, ÓXIDO  
 157 MOSAICO COSMOS LUX T5 BLANCO, BEIGE, NEGRO, ÓXIDO  
 229 MOSAICO CRISTALLO HEX AVORIO, BIANCO, GRIGIO, NERO  
 229 MOSAICO CRISTALLO LUX HEX AVORIO, BIANCO, GRIGIO, NERO  
 229 MOSAICO CRISTALLO T5 AVORIO, BIANCO, GRIGIO, NERO  
 229 MOSAICO CRISTALLO LUX T5 AVORIO, BIANCO, GRIGIO, NERO  
 235 MOSAICO DA VINCI LUX T5 WHITE  
 117 MOSAICO DOMINO SOFT I BLACK, MIX  
 117 MOSAICO DOMINO SOFT M WHITE  
 117 MOSAICO DOMINO SOFT T5 BLACK, WHITE  
 237 MOSAICO DUBAI DIAMOND ICE, GREY, GRAPHITE, TAUPE  
 237 MOSAICO DUBAI LUX DIAMOND ICE, GREY, GRAPHITE, TAUPE  
 237 MOSAICO DUBAI T5 ICE, GREY, GRAPHITE, TAUPE  
 237 MOSAICO DUBAI LUX T5 ICE, GREY, GRAPHITE, TAUPE  
 159 MOSAICO ELEKTRA LUX T5 BLACK, GRAPHITE, MIX, SUPERWHITE  
 163 MOSAICO FAME LUX HEX BLACK, PEARL  
 167 MOSAICO HARLEY LUX T5 BLACK, GRAPHITE, MIX, SUPERWHITE  
 251 MOSAICO INVISIBLE LUX HEX WHITE  
 251 MOSAICO INVISIBLE NAT HEX WHITE  
 41 MOSAICO KAI HEX ASH, GRAPHITE, GREIGE, PEARL  
 41 MOSAICO KAI T5 ASH, GRAPHITE, GREIGE, PEARL  
 283 MOSAICO LACIO SOFT V ARENA, IVORY  
 243 MOSAICO MACCHIA VECCHIA NAT PICKET GOLD, SILVER  
 243 MOSAICO MACCHIA VECCHIA LUX PICKET GOLD, SILVER  
 243 MOSAICO MACCHIA VECCHIA NAT T5 GOLD, SILVER  
 243 MOSAICO MACCHIA VECCHIA LUX T5 GOLD, SILVER  
 259 MOSAICO NAGOYA T5 CRYSTAL, GRAPHITE, GREIGE, GREY, MARFIL  
 259 MOSAICO NAGOYA LUX T5 CRYSTAL, GRAPHITE, GREIGE, GREY, MARFIL  
 259 MOSAICO NAGOYA HEX CRYSTAL, GRAPHITE, GREIGE, GREY, MARFIL  
 259 MOSAICO NAGOYA LUX HEX CRYSTAL, GRAPHITE, GREIGE, GREY, MARFIL  
 205 MOSAICO NAIROBI M GRIS, HAYA, ROBLE  
 265 MOSAICO ONYX LUX T5 IVORY, LIGHT GREY, DARK GREY, LIGHT GREEN, LIGHT BLUE  
 265 MOSAICO ONYX LUX V IVORY, LIGHT GREY, DARK GREY, LIGHT GREEN, LIGHT BLUE  
 269 MOSAICO PARADOX HEX GOLD, NATURE, WHITE  
 269 MOSAICO PARADOX LUX HEX GOLD, NATURE, WHITE  
 269 MOSAICO PARADOX T5 GOLD, NATURE, WHITE  
 269 MOSAICO PARADOX LUX T5 GOLD, NATURE, WHITE  
 275 MOSAICO PASSION LUX T5 CHAMPAGNE, GREY, ICE, TAUPE  
 277 MOSAICO PERLA VENATA HEX BLANCO, CREMA, GRIS, NEGRO  
 277 MOSAICO PERLA VENATA LEAF BLANCO, CREMA, GRIS, NEGRO  
 277 MOSAICO PERLA VENATA LUX HEX BLANCO, CREMA, GRIS, NEGRO  
 277 MOSAICO PERLA VENATA LUX LEAF BLANCO, CREMA, GRIS, NEGRO  
 277 MOSAICO PERLA VENATA LUX T5 BLANCO, CREMA, GRIS, NEGRO  
 277 MOSAICO PERLA VENATA T5 BLANCO, CREMA, GRIS, NEGRO  
 175 MOSAICO SAHARA SCINTILLANTE HEX DARK GREY, PEARL, SAND  
 49 MOSAICO SAN FRANCISCO LUX T5 WHITE, GREY, GRAPHITE, OXIDE, BLACK, AQUAMARINE  
 49 MOSAICO SAN FRANCISCO T5 WHITE, GREY, GRAPHITE, OXIDE, BLACK, AQUAMARINE  
 133 MOSAICO SEASTONE T5 GRAPHITE, GREY, TAUPE, WHITE  
 85 MOSAICO SENDAI HEX WHITE  
 137 MOSAICO SHELLSTONE T5 WHITE, GREY, CREAM, GREIGE  
 179 MOSAICO SMART LUX T5 BLACK, GRAPHITE, SUPERWHITE, WHITE  
 65 MOSAICO STUDIO T5 ASH, CREAM, GRAPHITE, GREY, WHITE  
 287 MOSAICO TIVOLI SOFT PICKET ARENA, IVORY  
 295 MOSAICO VULCANO LUX T5 ANTRACITE, BASALTO, MAGMA, QUARZO  
 N  
 259 NAGOYA 120 CRYSTAL, GRAPHITE, GREIGE, GREY, MARFIL

259 NAGOYA 60 CRYSTAL, GRAPHITE, GREIGE, GREY, MARFIL  
 259 NAGOYA 3060 CRYSTAL, GRAPHITE, GREIGE, GREY, MARFIL  
 259 NAGOYA 15x60 CRYSTAL, GRAPHITE, GREIGE, GREY, MARFIL  
 259 NAGOYA LUX 120 CRYSTAL, GRAPHITE, GREIGE, GREY, MARFIL  
 259 NAGOYA LUX 60 CRYSTAL, GRAPHITE, GREIGE, GREY, MARFIL  
 259 NAGOYA LUX 3060 CRYSTAL, GRAPHITE, GREIGE, GREY, MARFIL  
 259 NAGOYA LUX 15x60 CRYSTAL, GRAPHITE, GREIGE, GREY, MARFIL  
 205 NAIROBI 20 GRIS, HAYA, ROBLE  
 205 NAIROBI DRY 20 GRIS, HAYA, ROBLE  
 209 NEBRASKA 20 MIEL, NOGAL, ROBLE  
 209 NEBRASKA 30 MIEL, NOGAL, ROBLE  
 209 NEBRASKA DRY 20 MIEL, NOGAL, ROBLE  
 209 NEBRASKA DRY 30 MIEL, NOGAL, ROBLE  
 209 NEBRASKA HEX60 JENGA MIEL, NOGAL, ROBLE  
 O  
 265 ONYX LUX 120 IVORY, LIGHT GREY, DARK GREY, LIGHT GREEN, LIGHT BLUE  
 265 ONYX LUX 3060 IVORY, LIGHT GREY, DARK GREY, LIGHT GREEN, LIGHT BLUE  
 265 ONYX LUX 60 IVORY, LIGHT GREY, DARK GREY, LIGHT GREEN, LIGHT BLUE  
 267 ONYX R90 IVORY, LIGHT GREY, DARK GREY, LIGHT GREEN, LIGHT BLUE  
 267 ONYX R90 LOT IVORY, LIGHT GREY, DARK GREY, LIGHT GREEN, LIGHT BLUE  
 171 ORION LUX 120 BLUE, GREIGE, TITANIUM, COPPER, PEARL  
 171 ORION LUX 60 BLUE, GREIGE, TITANIUM, COPPER, PEARL  
 171 ORION SCINTILLANTE 120 BLUE, GREIGE, TITANIUM, COPPER, PEARL  
 171 ORION SCINTILLANTE 60 BLUE, GREIGE, TITANIUM, COPPER, PEARL  
 P  
 269 PARADOX 120 GOLD, NATURE, WHITE  
 269 PARADOX 3060 GOLD, NATURE, WHITE  
 269 PARADOX 60 GOLD, NATURE, WHITE  
 269 PARADOX 9090 GOLD, NATURE, WHITE  
 269 PARADOX LUX 120 GOLD, NATURE, WHITE  
 269 PARADOX LUX 3060 GOLD, NATURE, WHITE  
 269 PARADOX LUX 60 GOLD, NATURE, WHITE  
 275 PASSION LUX 120 CHAMPAGNE, GREY, ICE, TAUPE  
 275 PASSION LUX 3060 CHAMPAGNE, GREY, ICE, TAUPE  
 275 PASSION LUX 60 CHAMPAGNE, GREY, ICE, TAUPE  
 255 PATAGONIA LUX 120  
 255 PATAGONIA LUX 60  
 255 PATAGONIA NAT 120  
 255 PATAGONIA NAT 60  
 255 PATAGONIA NAT 9090  
 277 PERLA VENATA 120 BLANCO, CREMA, GRIS, NEGRO  
 277 PERLA VENATA 3060 BLANCO, CREMA, GRIS, NEGRO  
 277 PERLA VENATA 60 BLANCO, CREMA, GRIS, NEGRO  
 277 PERLA VENATA 9090 BLANCO, CREMA, GRIS, NEGRO  
 277 PERLA VENATA LUX 120 BLANCO, CREMA, GRIS, NEGRO  
 277 PERLA VENATA LUX 3060 BLANCO, CREMA, GRIS, NEGRO  
 277 PERLA VENATA LUX 60 BLANCO, CREMA, GRIS, NEGRO  
 123 PORTOPETRO R90 SALT SAND, WHITE  
 123 PORTOPETRO R90 SAND, WHITE  
 S  
 175 SAHARA SCINTILLANTE 120 DARK GREY, PEARL, SAND  
 175 SAHARA SCINTILLANTE 3060 DARK GREY, PEARL, SAND  
 175 SAHARA SCINTILLANTE 60 DARK GREY, PEARL, SAND  
 49 SAN FRANCISCO 120 WHITE, GREY, GRAPHITE, OXIDE, BLACK, AQUAMARINE  
 49 SAN FRANCISCO 3060 WHITE, GREY, GRAPHITE, OXIDE, BLACK, AQUAMARINE  
 49 SAN FRANCISCO 60 WHITE, GREY, GRAPHITE, OXIDE, BLACK, AQUAMARINE  
 49 SAN FRANCISCO HEX60 WHITE, GREY, GRAPHITE, BLACK, AQUAMARINE  
 49 SAN FRANCISCO DRY 120 AQUAMARINE  
 49 SAN FRANCISCO DRY 3060 AQUAMARINE

49 SAN FRANCISCO DRY 60 AQUAMARINE  
 49 SAN FRANCISCO LUX 120 WHITE, GREY, GRAPHITE, OXIDE, BLACK, AQUAMARINE  
 49 SAN FRANCISCO LUX 3060 WHITE, GREY, GRAPHITE, OXIDE, BLACK, AQUAMARINE  
 49 SAN FRANCISCO LUX 60 WHITE, GREY, GRAPHITE, OXIDE, BLACK, AQUAMARINE  
 129 SANTANYI 120 BEIGE, GREY, SAND, WHITE  
 129 SANTANYI 60 BEIGE, GREY, SAND, WHITE  
 129 SANTANYI 9090 BEIGE, GREY, SAND, WHITE  
 129 SANTANYI C2 120 GREY, SAND  
 129 SANTANYI C2 60 GREY, SAND  
 129 SANTANYI C2 9090 GREY, SAND  
 129 SANTANYI DRY 120 GREY, SAND  
 129 SANTANYI DRY 60 GREY, SAND  
 129 SANTANYI DRY 9090 GREY, SAND  
 133 SEASTONE 120 GRAPHITE, GREY, TAUPE, WHITE  
 133 SEASTONE 60 GRAPHITE, GREY, TAUPE, WHITE  
 133 SEASTONE DRY 120 GREY, TAUPE  
 133 SEASTONE DRY 60 GREY, TAUPE  
 85 SENSE R90 BLUE, GREY, ROSE, TERRA, WHITE  
 85 SENSE R90 SKY BLUE, GREY, ROSE, TERRA, WHITE  
 137 SHELLSTONE 120 WHITE, GREY, CREAM, GREIGE  
 137 SHELLSTONE 120x120 WHITE, GREY, CREAM, GREIGE  
 137 SHELLSTONE 3060 WHITE, GREY, CREAM, GREIGE  
 137 SHELLSTONE 60 WHITE, GREY, CREAM, GREIGE  
 137 SHELLSTONE 9090 WHITE, GREY, CREAM, GREIGE  
 137 SHELLSTONE DRY 120 WHITE, GREY, CREAM, GREIGE  
 137 SHELLSTONE DRY 120x120 GREY, CREAM  
 137 SHELLSTONE DRY 3060 WHITE, GREY, CREAM, GREIGE  
 137 SHELLSTONE DRY 60 WHITE, GREY, CREAM, GREIGE  
 137 SHELLSTONE DRY 9090 WHITE, GREY, CREAM, GREIGE  
 141 SHELLSTONE R90 LOT WHITE, GREY, CREAM, GREIGE  
 141 SHELLSTONE R90 WHITE, GREY, CREAM, GREIGE  
 187 SLATS BARRICA 120 BONE, CHOCOLATE, GRIS, MIEL, NUEZ  
 247 SLATS BOMBAY LUX 120  
 251 SLATS INVISIBLE LUX 120 WHITE  
 251 SLATS INVISIBLE NAT 120 WHITE  
 199 SLATS LEGNO 120 BETULLA, FAGGIO, NOCE, ROVERE  
 255 SLATS PATAGONIA LUX 120  
 255 SLATS PATAGONIA NAT 120  
 179 SMART LUX 3060 BLACK, GRAPHITE, SUPERWHITE, WHITE  
 179 SMART LUX 60 BLACK, GRAPHITE, SUPERWHITE, WHITE  
 145 STONEAGE 120 GRAPHITE, GREY, IVORY, SAND  
 145 STONEAGE 3060 GRAPHITE, GREY, IVORY, SAND  
 145 STONEAGE 60 GRAPHITE, GREY, IVORY, SAND  
 145 STONEAGE DRY 120 GRAPHITE, GREY, IVORY, SAND  
 145 STONEAGE DRY 3060 GRAPHITE, GREY, IVORY, SAND  
 145 STONEAGE DRY 60 GRAPHITE, GREY, IVORY, SAND  
 145 STONEAGE LUX 120 GRAPHITE, GREY, IVORY, SAND  
 145 STONEAGE LUX 3060 GRAPHITE, GREY, IVORY, SAND  
 145 STONEAGE LUX 60 GRAPHITE, GREY, IVORY, SAND  
 145 STONEAGE R3060 RECT GRAPHITE, GREY, IVORY, SAND  
 149 STONEAGE R3060 RECT KIT GRAPHITE, GREY, IVORY, SAND  
 59 STONECRETE MOSAIC BRICK AGATA ASH  
 59 STONECRETE MOSAIC BRICK VENEZIA SAND  
 59 STONECRETE MOSAIC HEX RIALTO WHITE  
 59 STONECRETE MOSAIC HEX TULUM SAND  
 STREET 120 ASH, SAND, WHITE  
 STREET 3060 ASH, SAND, WHITE  
 STREET 60 ASH, SAND, WHITE  
 STREET 9090 ASH, SAND, WHITE

59 STREET DRY 120 ASH, SAND  
 59 STREET DRY 60 ASH, SAND  
 59 STREET DRY 9090 ASH, SAND  
 65 STUDIO 120 ASH, CREAM, GRAPHITE, GREY, WHITE  
 65 STUDIO 120x120 ASH, CREAM, GREY, WHITE  
 65 STUDIO 3060 ASH, CREAM, GRAPHITE, GREY, WHITE  
 65 STUDIO 60 ASH, CREAM, GRAPHITE, GREY, WHITE  
 65 STUDIO 9090 ASH, CREAM, GRAPHITE, GREY, WHITE  
 65 STUDIO DRY 120 ASH, CREAM, GRAPHITE, GREY, WHITE  
 65 STUDIO DRY 120x120 ASH, CREAM  
 65 STUDIO DRY 3060 ASH, CREAM, GRAPHITE, GREY, WHITE  
 65 STUDIO DRY 60 ASH, CREAM, GREY, GRAPHITE, WHITE  
 65 STUDIO DRY 9090 ASH, CREAM, WHITE  
 65 STUDIO LUX 120 ASH, CREAM, GRAPHITE, GREY, WHITE  
 65 STUDIO LUX 3060 ASH, CREAM, GRAPHITE, GREY, WHITE  
 65 STUDIO LUX 60 ASH, CREAM, GRAPHITE, GREY, WHITE  
 69 STUDIO R3060 RECT ASH, WHITE  
 69 STUDIO R3060 RECT SLIP ASH, WHITE  
 69 STUDIO R90 ASH, GRAPHITE, WHITE  
 69 STUDIO R90 SLIP ASH, GRAPHITE, WHITE  
 181 SYNTHESIS 120 BLACK, GREY, WHITE  
 181 SYNTHESIS 3060 BLACK, GREY, WHITE  
 181 SYNTHESIS 60 BLACK, GREY, WHITE  
 183 SYNTHESIS R90 BLACK, GREY, WHITE  
 183 SYNTHESIS R90 MILL BLACK, GREY, WHITE  
 T  
 287 TIVOLI SOFT 120 ARENA, IVORY  
 287 TIVOLI SOFT 120 KIDDLE ARENA, IVORY  
 287 TIVOLI SOFT 3060 ARENA, IVORY  
 287 TIVOLI DRY 120 ARENA, IVORY  
 287 TIVOLI MOSAIC HEX CROCHETE ARENA  
 151 TOSCANA 60 BEIGE, BLANCO, GRAFITO, GRIS  
 151 TOSCANA 9090 BEIGE, BLANCO, GRAFITO, GRIS  
 151 TOSCANA DRY 9090 BEIGE, GRIS  
 153 TOSCANA R3060 RECT BEIGE, BLANCO, GRIS  
 153 TOSCANA R3060 RECT SIL BEIGE, BLANCO, GRIS, MIX  
 153 TOSCANA R90 BEIGE, BLANCO, GRIS  
 153 TOSCANA R90 PLANE BEIGE, BLANCO, GRIS  
 316 TURQUETA 5x15 GLOSSY BLUE, GREEN, SALVIA, WHITE  
 316 TURQUETA 5x15 MATT BLUE, GREEN, SALVIA, WHITE  
 U  
 93 UNIK R120 QUEEN WHITE GLOSSY, WHITE MATT  
 93 UNIK R120 WHITE GLOSSY, WHITE MATT  
 93 UNIK R3060 RECT WHITE GLOSSY, WHITE MATT  
 93 UNIK R90 BLACK GLOSSY, WHITE GLOSSY, WHITE MATT  
 93 UNIK R90 BUBBLES BLACK GLOSSY, WHITE GLOSSY, WHITE MATT  
 93 UNIK R90 DUNES WHITE GLOSSY  
 93 UNIK R90 FROST WHITE GLOSSY, WHITE MATT  
 93 UNIK R90 JUNGLE WHITE SHADOW, WHITE SHINY  
 93 UNIK R90 VIBE WHITE GLOSSY, WHITE MATT  
 V  
 291 VICHY LUX 60 BLANCO, CREMA, GRIS  
 293 VICHY R90 BLANCO, CREMA, GRIS  
 91 VIENA R120 WHITE  
 295 VULCANO LUX 120 ANTRACITE, BASALTO, MAGMA, QUARZO  
 295 VULCANO LUX 60 ANTRACITE, BASALTO, MAGMA, QUARZO  
 295 VULCANO LUX 3060 ANTRACITE, BASALTO, MAGMA, QUARZO  
 295 VULCANO MOSAIC BRICK FOLIAGE QUARZO  
 295 VULCANO MOSAIC HEX FOLIAGE QUARZO





**CEMENTO | CONCRETE · COTTO**

ARGILLE · NEW	16 - 19
BALI	20 - 29
CEMENT · NEW	30 - 39
KAI	40 - 47
SAN FRANCISCO	48 - 53
STONECRETE · DISTRICT	54 - 57
STONECRETE · STREET	58 - 63
STUDIO · NEW	64 - 71

**AZTECA**





wall: SANTANYI 120 WHITE (60x120 cm).  
floor: ARGILLE HEX60 ARENA (52x60 cm).



wall: TURQUETA 5x15 GREEN MATT (5x15 cm).  
floor: ARGILLE 60 TERRACOTA (60x60 cm).



# ARGILLE collection

| PORCELÁNICO · PORCELAIN | RECTIFICADO · RECTIFIED | DESTONIFICADO V3 · DESTONIFIED V3 |

ESCALA DE LA GRÁFICA 1/2 - GRAPHIC SCALE 1/2 |

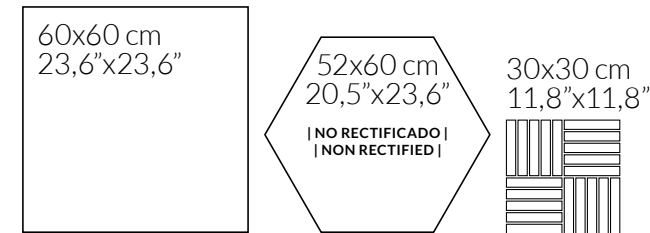

FORMATOS DISPONIBLES AVAILABLE FORMATS	ACABADO NATURAL · NATURAL FINISH
60x60 cm · 23,6"x23,6"	
52x60 cm · 20,5"x23,6"	ARGILLE 60   B35
	ARGILLE HEX60   B12
	DECORADO ARGILLE HEX60   B14 (arena, teja, terracota)
30x30 cm · 11,8"x11,8"	MOSAICO ARGILLE CROSS   P15  (arena-terracota)
Nº DISEÑOS POR FORMATO · Nº DESIGNS BY FORMAT:   60x60: 15   52x60: 15   RHOMBOID 52x60: 8	

| PIEZAS DECORATIVAS · DECORATIVE PIECES |

MOSAICO ARGILLE CROSS | 30x30 cm | P15



ARENA-TERRACOTA



AQUAMARINE ARENA TEJA TERRACOTA DEEP BLUE

COLORES DISPONIBLES · AVAILABLE COLORS |





floor: ARGILLE HEX60 ARENA (52x60 cm), DECORADO ARGILLE HEX60 ARENA (52x60 cm).

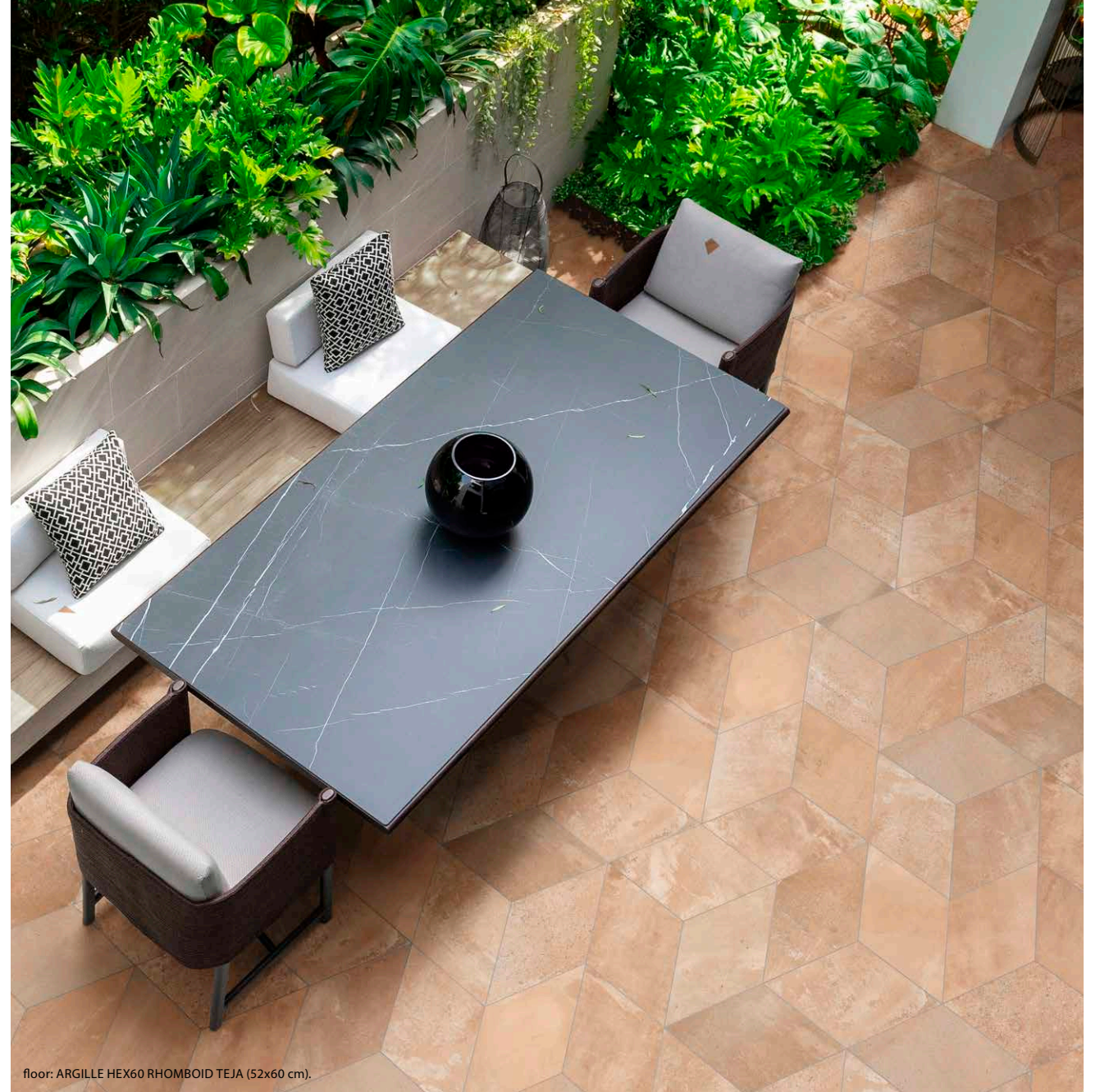

floor: ARGILLE HEX60 RHOMBOID TEJA (52x60 cm).

| PIEZAS DECORATIVAS - DECORATIVE PIECES |

DECORADO ARGILLE HEX60 | 52x60 cm | **B14** Siete piezas diferentes. Unidad de venta: 1 caja. - Seven different pieces. Sales unit: 1 box



ARENA

TEJA

TERRACOTA

| PIEZAS DECORATIVAS - DECORATIVE PIECES |

ARGILLE HEX60 RHOMBOID | 52x60 cm | **B12**

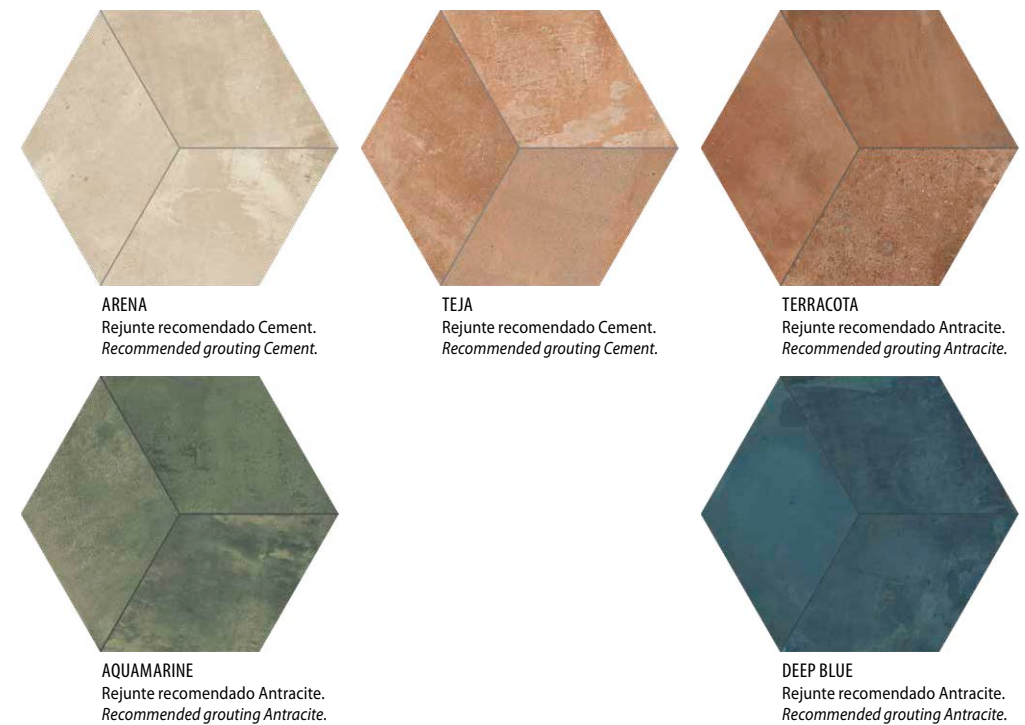

ARENA  
Rejunte recomendado Cement.  
Recommended grouting Cement.

TEJA  
Rejunte recomendado Cement.  
Recommended grouting Cement.

TERRACOTA  
Rejunte recomendado Antracite.  
Recommended grouting Antracite.

AQUAMARINE  
Rejunte recomendado Antracite.  
Recommended grouting Antracite.

DEEP BLUE  
Rejunte recomendado Antracite.  
Recommended grouting Antracite.





wall and floor: BALI LUX 120 GREY (60x120 cm).

# BALI collection

| PORCELÁNICO · PORCELAIN | RECTIFICADO · RECTIFIED | DESTONIFICADO V2 · DESTONIFIED V2 |

| ESCALA DE LA GRÁFICA 1/2 · GRAPHIC SCALE 1/2 |

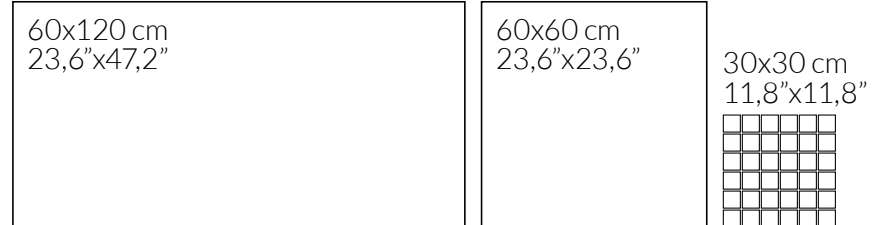

FORMATOS DISPONIBLES AVAILABLE FORMATS	ACABADO NATURAL NATURAL FINISH	ACABADO ANTIDESLIZANTE SLIP RESISTANCE FINISH	ACABADO LAPADO BRILLO GLOSSY LAPATTO FINISH
60x120 cm · 23,6" x 47,2"	BALI 120   B85	BALI DRY 120   B86	BALI LUX 120   B83
60x60 cm · 23,6" x 23,6"	BALI 60   B35	BALI DRY 60   B36	BALI LUX 60   B37
30x30 cm · 11,8" x 11,8"	MOSAICO BALI T5   P70	---	MOSAICO BALI LUX T5   P60
TAMAÑO DEL LIENZO: 133x420 cm · GRAPHIC CHART SIZE: 52,4" x 165,4"			

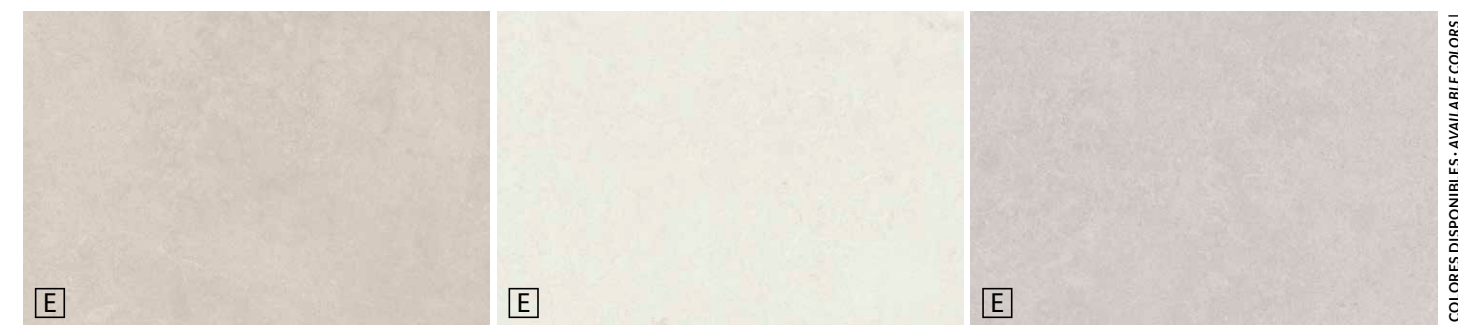

TAUPE

WHITE

GREY

| COLORES DISPONIBLES · AVAILABLE COLORS |





wall: DECORADO BELA R90 (30x90 cm).  
floor: BALI LUX 60 TAUPE Y WHITE (60x60 cm).

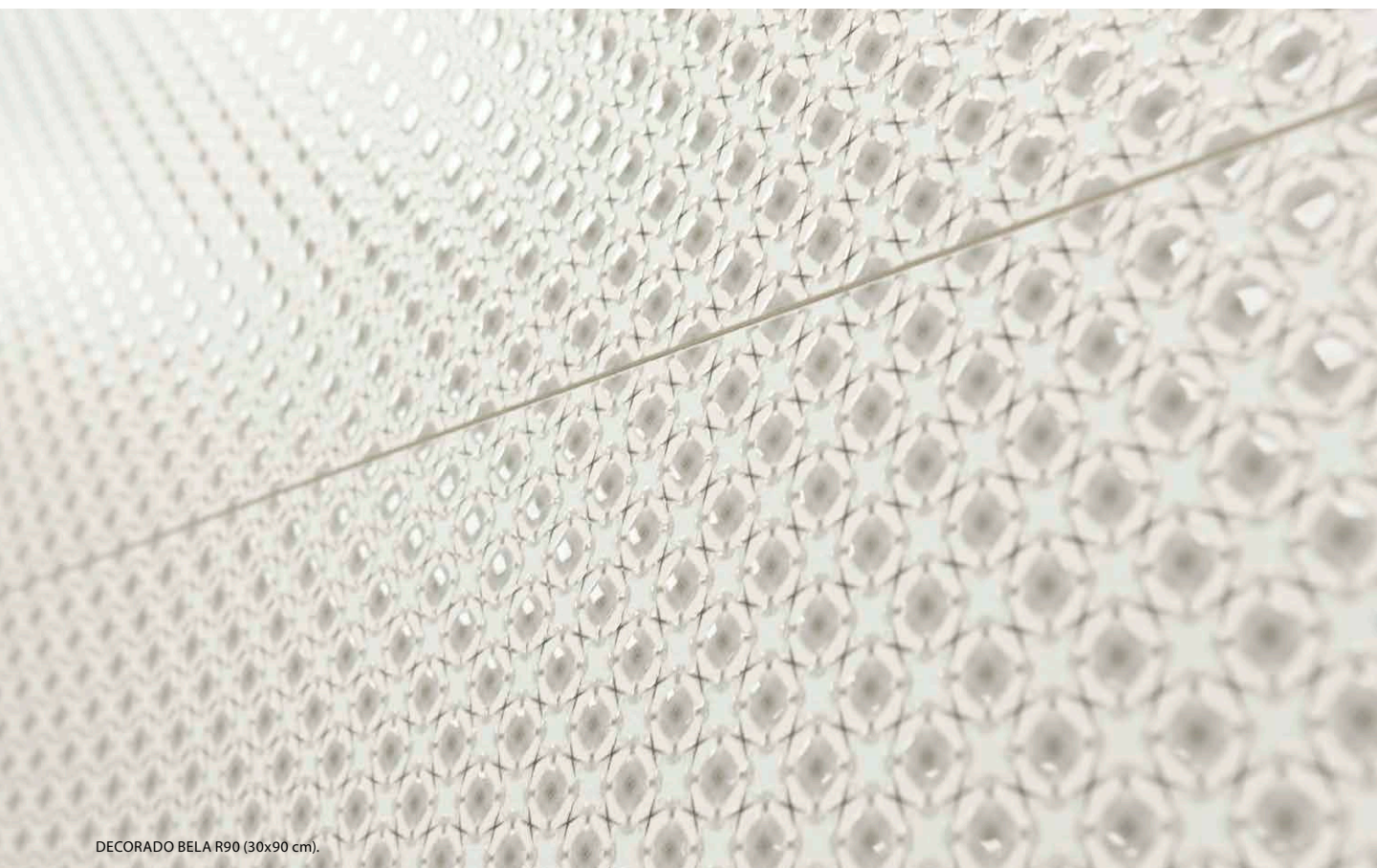

DECORADO BELA R90 (30x90 cm).



wall: BALI 120 WHITE (60x120 cm).  
floor: BALI 120 WHITE (60x120 cm), BALI DRY 120 TAUPE (60x120 cm).





wall: BALI R90 GREY (30x90cm), BALI R90 TRICOT WHITE Y GREY (30x90cm).  
floor: BALI 60 WHITE Y GREY (60x60cm).



BALI R90 TRICOT GREY (30x90cm).

| PIEZAS DECORATIVAS · DECORATIVE PIECES |

DECORADO BELA R90 | 30x90 cm | B44



DECORADO PALM R90 WHITE MATT | 30x90 cm | B44

Cinco piezas diferentes. Unidad de venta: 1 caja. - Five different pieces. Sales unit: 1 box.



DECORADO 2 GARDEN R90 WHITE | 30x90 cm | P74

Formado por dos piezas. Unidad de venta: 1 caja. - It's made up of two pieces. Sales unit: 1 box.



DECORADO BRUSH R90 | 30x90 cm | B44

Tres piezas diferentes. Unidad de venta: 1 caja. - Three different pieces. Sales unit: 1 box.



DECORADO BRUSH R90 | 30x90 cm | P65

Colocación y mantenimiento de baldosas cerámicas con recubrimiento PVD. Página 328.  
Placement and maintenance of ceramic tiles with PVD coating. Page 329.



GOLD



SILVER

BALI R90 TRICOT | 30x90 cm | B43

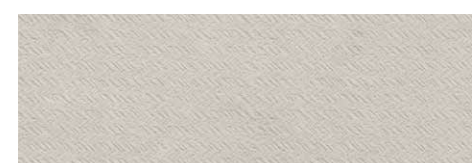

TAUPE

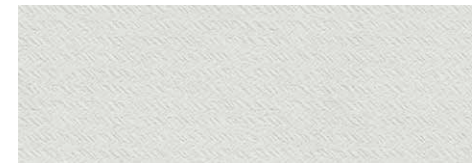

WHITE

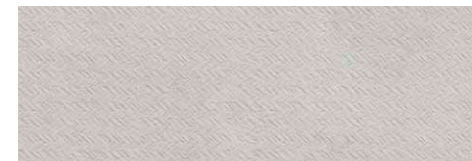

GREY

# BALI

collection

| PASTA BLANCA · WHITE BODY |  
| RECTIFICADO · RECTIFIED |  
| DESTONIFICADO V2 · DESTONIFIED V2 |

30x90 cm  
11,8"x35,4"

FORMATOS DISPONIBLES AVAILABLE FORMATS	ACABADO MATE · MATT FINISH
30x90 cm · 11,8"x35,4"	BALI R90   B42
	DECORADO BELA R90   B44
	DECORADO PALM R90   B44
	DECORADO 2 GARDEN R90   P74
	DECORADO BRUSH R90   B44
	DECORADO BRUSH R90   P65  (gold, silver)
	DECORADO BLOOM R90   B44  (taupe, white)
BALI R90 TRICOT   B43	
TAMAÑO DEL LIENZO: 133x420 cm · GRAPHIC CHART SIZE: 52,4"x165,4"	

DECORADO BLOOM R90 | 30x90 cm | B44

Tres piezas diferentes. Unidad de venta: 1 caja. - Three different pieces. Sales unit: 1 box.



TAUPE

WHITE



TAUPE

WHITE

GREY









wall: DECORADO PALM R90 WHITE MATT (30x90 cm), BALI R90 WHITE (30x90 cm).  
floor: BARRICA 30 NUEZ (30x120 cm).



wall: BALI R90 WHITE Y GREY (30x90 cm), DECORADO BRUSH R90 (30x90 cm).  
floor: BALI LUX 60 GREY (60x60 cm).



DECORADO BRUSH R90 (30x90 cm).









floor: CEMENT 9090 PEARL (90x90 cm)  
table: SHELLSTONE 9090 GREIGE (90x90 cm).

# CEMENT collection

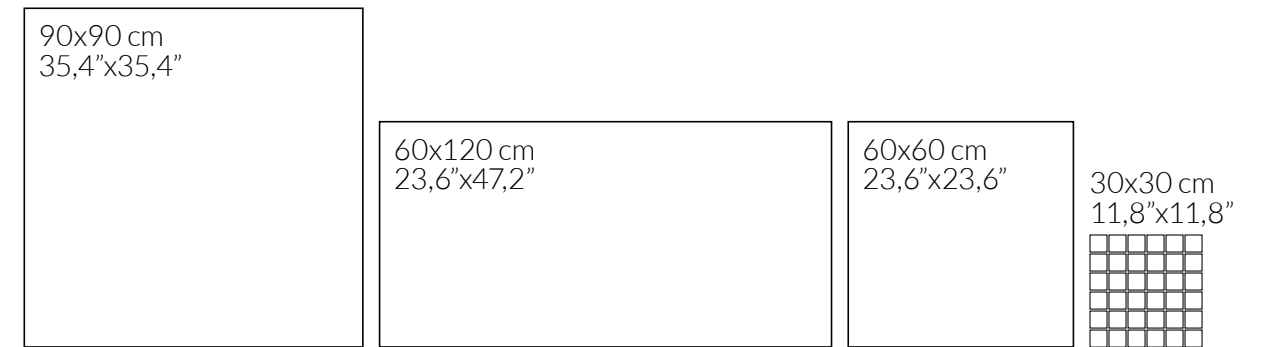
| PORCELÁNICO · PORCELAIN | RECTIFICADO · RECTIFIED | DESTONIFICADO V2 · DESTONIFIED V2 |

ESCALA DE LA GRÁFICA 1/2 - GRAPHIC SCALE 1/2 |



FORMATOS DISPONIBLES AVAILABLE FORMATS	ACABADO NATURAL NATURAL FINISH  1 >0,42	ACABADO ANTIDESLIZANTE SLIP RESISTANCE FINISH  3 >0,61 >36
90x90 cm · 35,4"x35,4"	<b>CEMENT 9090   B50</b>	<b>CEMENT DRY 9090   B51</b>
60x120 cm · 23,6"x47,2"	<b>CEMENT 120   B85</b>	<b>CEMENT DRY 120   B86</b>
60x60 cm · 23,6"x23,6"	<b>CEMENT 60   B35</b>	<b>CEMENT DRY 60   B36</b>
30x30 cm · 11,8"x11,8"	<b>MOSAICO CEMENT T5   P70</b> 	---
TAMAÑO DEL LIENZO: 100x300 cm · GRAPHIC CHART SIZE: 39,4"x118,1"		

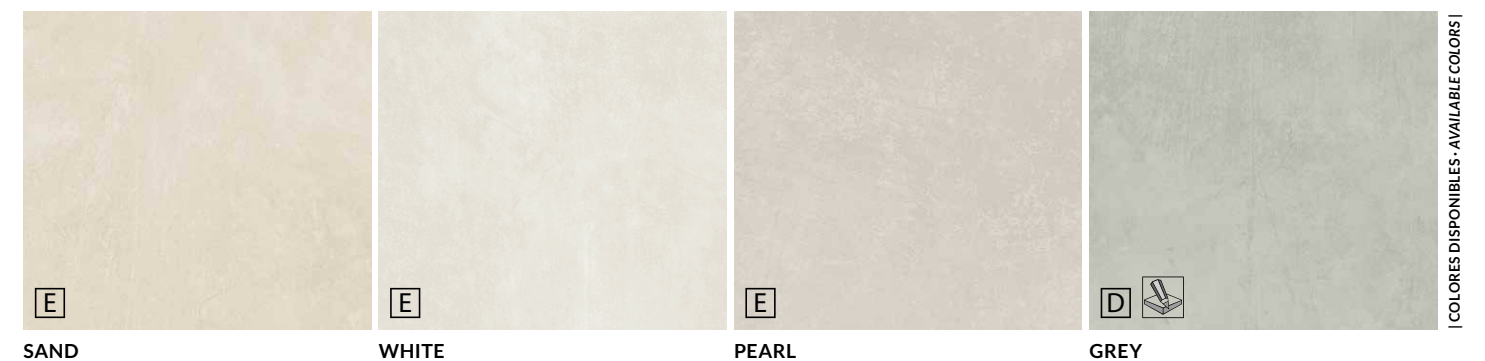

COLORES DISPONIBLES · AVAILABLE COLORS |





wall: CEMENT 120 PEARL (60x120 cm).  
floor: CEMENT 120 GREY (60x120 cm).



floor: CEMENT DRY 120 SAND (60x120 cm).



wall: CEMENT 120 WHITE (60x120 cm).  
floor: CEMENT 120 SAND (60x120 cm).





wall: CEMENT R90 WHITE (30x90cm), DECORADO CHLOE R90 (30x90cm).  
floor: CEMENT 60 GREY (60x60cm).



DECORADO CHLOE R90 (30x90cm).

# CEMENT collection

| PASTA BLANCA · WHITE BODY | RECTIFICADO · RECTIFIED | DESTONIFICADO V2 · DESTONIFIED V2 |

| ESCALA DE LA GRÁFICA 1/2 · GRAPHIC SCALE 1/2 |

**| PIEZAS DECORATIVAS · DECORATIVE PIECES |**

**DECORADO CHLOE R90 | 30x90 cm | B44**  
Tres piezas diferentes. Unidad de venta: 1 caja. · Three different pieces. Sales unit: 1 box.



**DECORADO COZY R90 | 30x90 cm | B44**  
Cinco piezas diferentes. Unidad de venta: 1 caja. · Five different pieces. Sales unit: 1 box.



**DECORADO CANDY R90 | 30x90 cm | B44**  
Cinco piezas diferentes. Unidad de venta: 1 caja. · Five different pieces. Sales unit: 1 box.

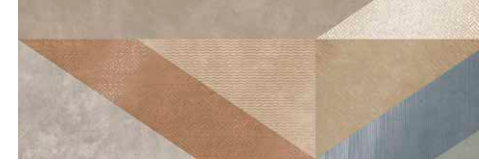

**CEMENT R90 CODE | 30x90 cm | B43**



SAND



WHITE



SAND

WHITE

PEARL

GREY

| COLORES DISPONIBLES · AVAILABLE COLORS |

30x90 cm  
11,8"x35,4"

FORMATOS DISPONIBLES AVAILABLE FORMATS	ACABADO MATE · MATT FINISH 
30x90 cm · 11,8"x35,4"	CEMENT R90   B42
	DECORADO CHLOE R90   B44 
	DECORADO COZY R90   B44 
	DECORADO CANDY R90   B44 
	CEMENT R90 CODE   B43  (sand, white)
TAMAÑO DEL LIENZO: 100x300 cm · GRAPHIC CHART SIZE: 39,4"x118,1"	





wall: CEMENT R90 CODE WHITE (30x90 cm).  
floor: CEMENT 120 GREY (60x120 cm), CEMENT DRY 120 GREY (60x120 cm).



CEMENT R90 CODE SAND (30x90 cm).





wall: CEMENT R90 PEARL (30x90 cm), DECORADO COZY R90 (30x90 cm).  
floor: CEMENT 60 PEARL (60x60 cm).



wall: CEMENT R90 WHITE (30x90 cm), DECORADO CANDY R90 (30x90 cm).  
floor: CEMENT 60 WHITE (60x60 cm).



DECORADO CANDY R90 (30x90cm).





floor: KAI 120 GRAPHITE (60x120 cm)

# KAI collection

| PORCELÁNICO · PORCELAIN | RECTIFICADO · RECTIFIED | DESTONIFICADO V2 · DESTONIFIED V2 |

ESCALA DE LA GRÁFICA 1/2 · GRAPHIC SCALE 1/2 |

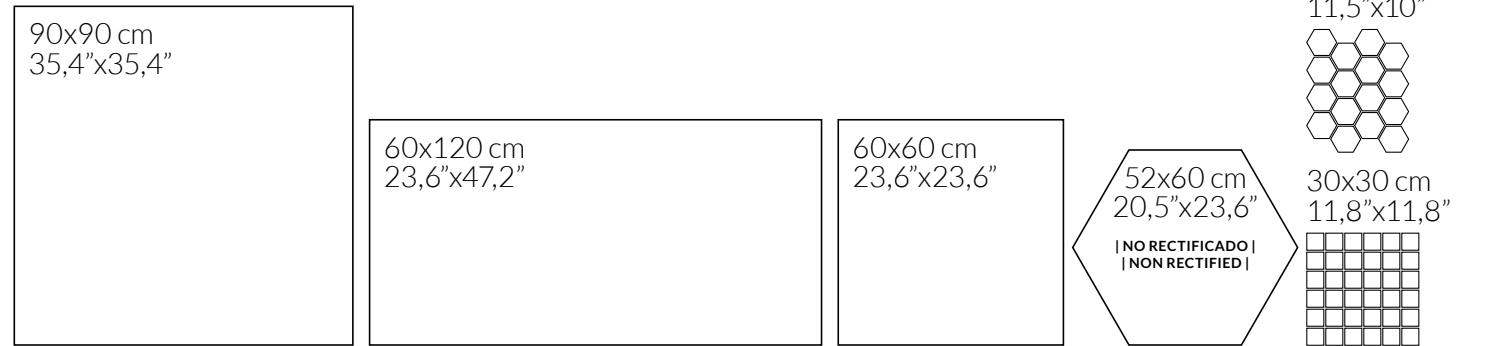

FORMATOS DISPONIBLES AVAILABLE FORMATS	ACABADO NATURAL · NATURAL FINISH
90x90 cm · 35,4"x35,4"	KAI 9090   B50 DECORADO KAI 9090   B53
60x120 cm · 23,6"x47,2"	KAI 120   B85 DECORADO KAI 120   B84
60x60 cm · 23,6"x23,6"	KAI 60   B35
52x60 cm · 20,5"x23,6"	KAI HEX60   B12 DECORADO KAI HEX60   B15
30x30 cm · 11,8"x11,8"	MOSAICO KAI T5   P70
29,3x25,4 cm · 11,5"x10"	MOSAICO KAI HEX   P15
Nº DISEÑOS POR FORMATO · Nº DESIGNS BY FORMAT:   90x90: 8   60x120: 8   60x60: 16   52x60: 16	

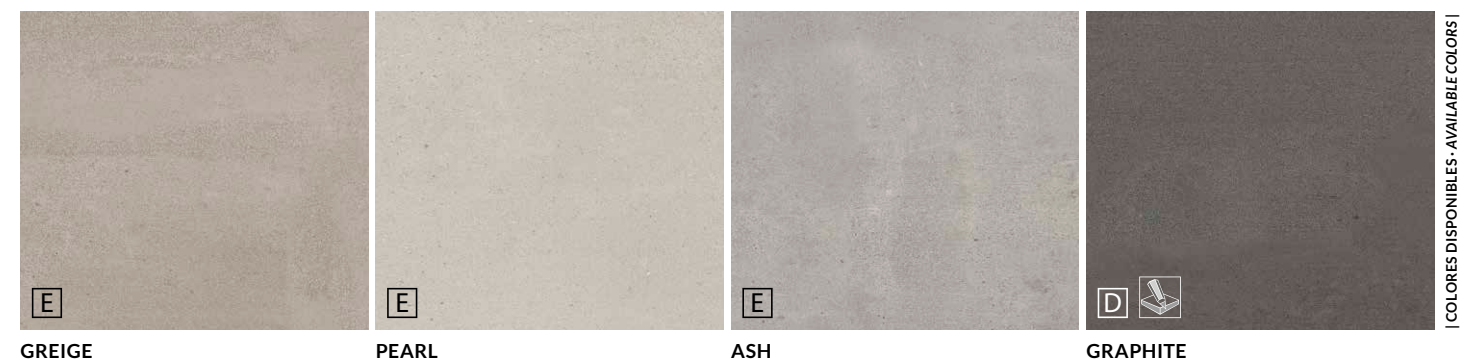

COLORES DISPONIBLES · AVAILABLE COLORS |





floor: KAI 9090 PEARL (90x90 cm).



floor: DECORADO KAI 9090 ASH (90x90 cm).

| PIEZAS DECORATIVAS · DECORATIVE PIECES |

DECORADO KAI 9090 | 90x90 cm | B53

Ocho piezas diferentes. Unidad de venta: 1 caja. · Eight different pieces. Sales unit: 1 box.



PEARL



ASH



GREIGE



GRAPHITE





wall: KAI HEX60 PEARL (52x60 cm), DECORADO KAI HEX60 PEARL (52x60 cm).

| PIEZAS DECORATIVAS - DECORATIVE PIECES |

DECORADO KAI HEX60 | 52x60 cm | B15

Dieciséis piezas diferentes. Unidad de venta: 1 caja. Sixteen different pieces. Sales unit: 1 box.

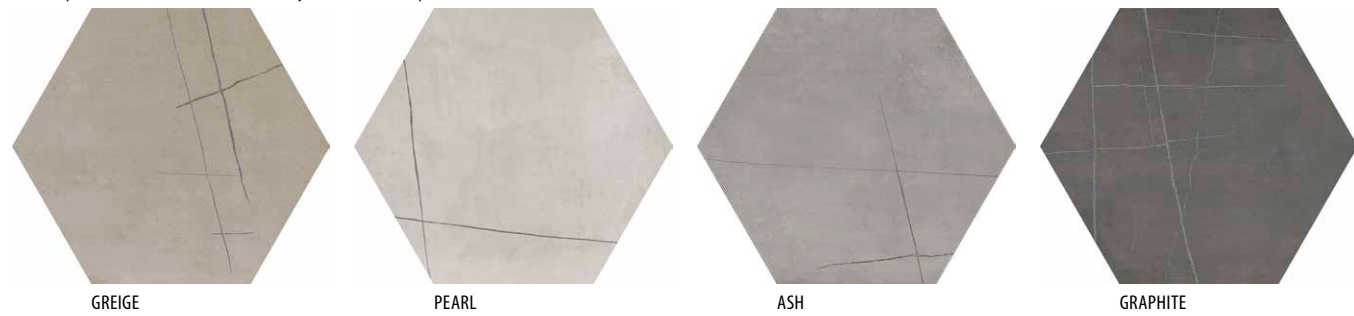

GREIGE

PEARL

ASH

GRAPHITE



floor: KAI 120 GREIGE (60x120 cm), DECORADO KAI 120 GREIGE (60x120 cm).

DECORADO KAI 120 | 60x120 cm | B84

Ocho piezas diferentes. Unidad de venta: 1 caja. Eight different pieces. Sales unit: 1 box.

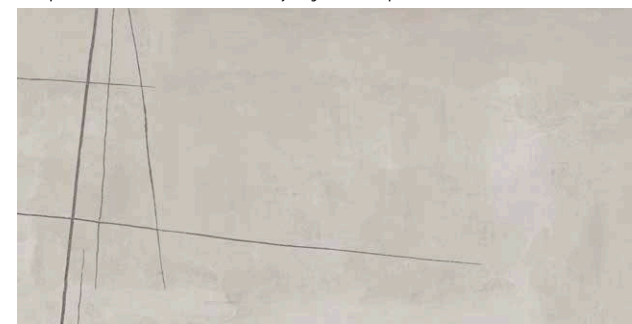

PEARL



ASH

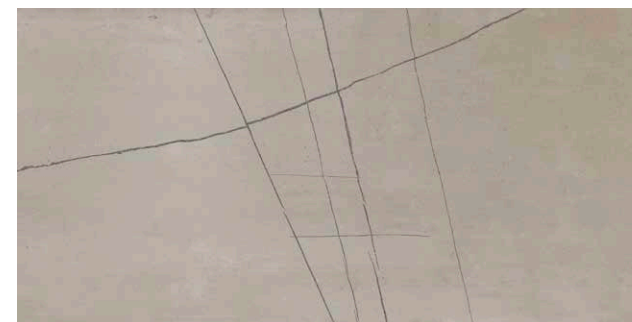

GREIGE



GRAPHITE





wall: KAI R120 GREIGE Y WHITE (40x120 cm), DECORADO KAROL R120 GREIGE (40x120 cm).  
floor: KAI 60 GREIGE (60x60 cm).









wall: DECORADO KAROL R120 GREIGE (40x120 cm).

# KAI collection

| PASTA BLANCA · WHITE BODY | RECTIFICADO · RECTIFIED | DESTONIFICADO V2 · DESTONIFIED V2 |

40x120 cm  
15,7"x47,2"

FORMATOS DISPONIBLES AVAILABLE FORMATS	ACABADO MATE · MATT FINISH   
40x120 cm · 15,7"x47,2"	KAI R120   B94
	DECORADO KRONOS R120   B99  (pearl)
	DECORADO KAROL R120   B95   (greige)
Nº DISEÑOS POR FORMATO · Nº DESIGNS BY FORMAT:   40x120: 6	

## PIEZAS DECORATIVAS · DECORATIVE PIECES |

DECORADO KAROL R120 | 40x120 cm | B95

Tres piezas diferentes. Unidad de venta: 1 caja. · Three different pieces. Sales unit: 1 box.



GREIGE

DECORADO KRONOS R120 | 40x120 cm | B99

Cuatro piezas diferentes. Unidad de venta: 1 caja. · Four different pieces. Sales unit: 1 box.

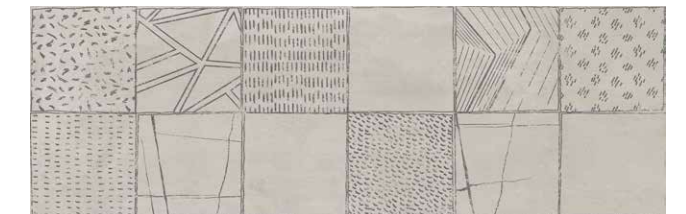

PEARL

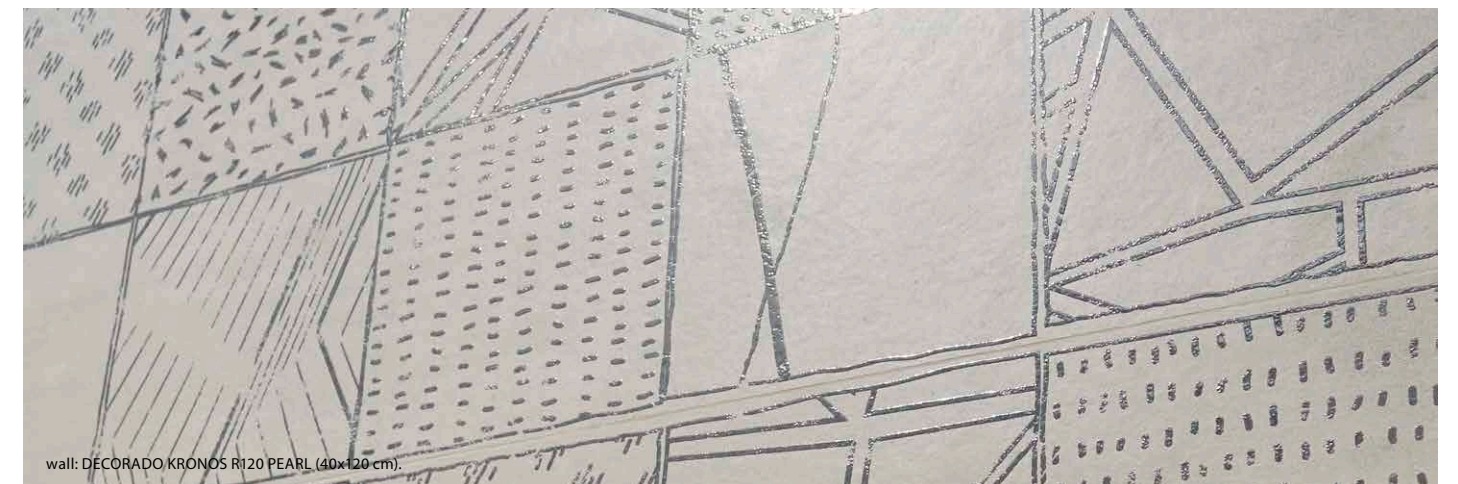

wall: DECORADO KRONOS R120 PEARL (40x120 cm).



GREIGE

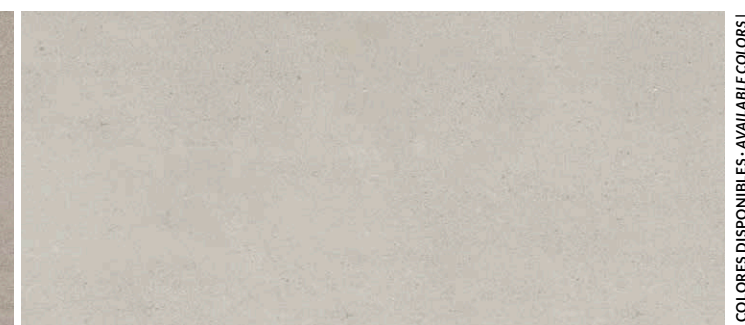

PEARL

COLORES DISPONIBLES · AVAILABLE COLORS |





wall: SAN FRANCISCO 120 WHITE (60x120 cm), SAN FRANCISCO 60 AQUAMARINE (60x60 cm).  
 floor: SAN FRANCISCO 120 AQUAMARINE (60x120 cm).

# SAN FRANCISCO collection

| PORCELÁNICO · PORCELAIN | RECTIFICADO · RECTIFIED | DESTONIFICADO V3 · DESTONIFIED V3 |

| ESCALA DE LA GRÁFICA 1/2 · GRAPHIC SCALE 1/2 |

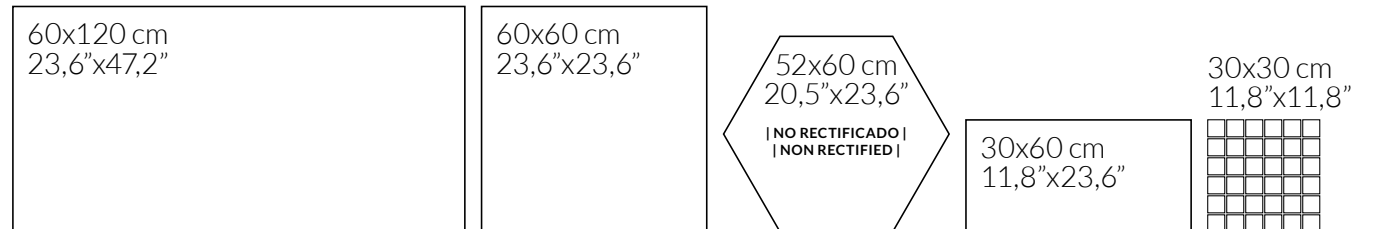

FORMATOS DISPONIBLES AVAILABLE FORMATS	ACABADO NATURAL NATURAL FINISH 	ACABADO ANTIDESLIZANTE SLIP RESISTANCE FINISH 	ACABADO LAPADO BRILLO GLOSSY LAPATTO FINISH 
60x120 cm · 23,6" x 47,2"	SAN FRANCISCO 120   B85	SAN FRANCISCO DRY 120   B86 (aquamarine, white)	SAN FRANCISCO LUX 120   B83
60x60 cm · 23,6" x 23,6"	SAN FRANCISCO 60   B35	SAN FRANCISCO DRY 60   B36 (aquamarine)	SAN FRANCISCO LUX 60   B37
52x60 cm · 20,5" x 23,6"	SAN FRANCISCO HEX60   B12 (excepto color oxide · except oxide color) DECORADO SAN FRANCISCO HEX60   B14 (white)	---	---
30x60 cm · 11,8" x 23,6"	SAN FRANCISCO 3060   B35	SAN FRANCISCO DRY 3060   B36 (aquamarine)	SAN FRANCISCO LUX 3060   B37
30x30 cm · 11,8" x 11,8"	MOSAICO SAN FRANCISCO T5   P70 	---	MOSAICO SAN FRANCISCO LUX T5   P60 
Nº DISEÑOS POR FORMATO · Nº DESIGNS BY FORMAT:   60x120: 10   60x60: 12   52x60: 10   30x60: 24			



AQUAMARINE WHITE GREY GRAPHITE BLACK OXIDE

| COLORES DISPONIBLES · AVAILABLE COLORS |





wall and floor: SAN FRANCISCO HEX60 WHITE (52x60 cm), DECORADO SAN FRANCISCO HEX60 WHITE (52x60 cm), BARRICA 30 NUEZ (30x120 cm).

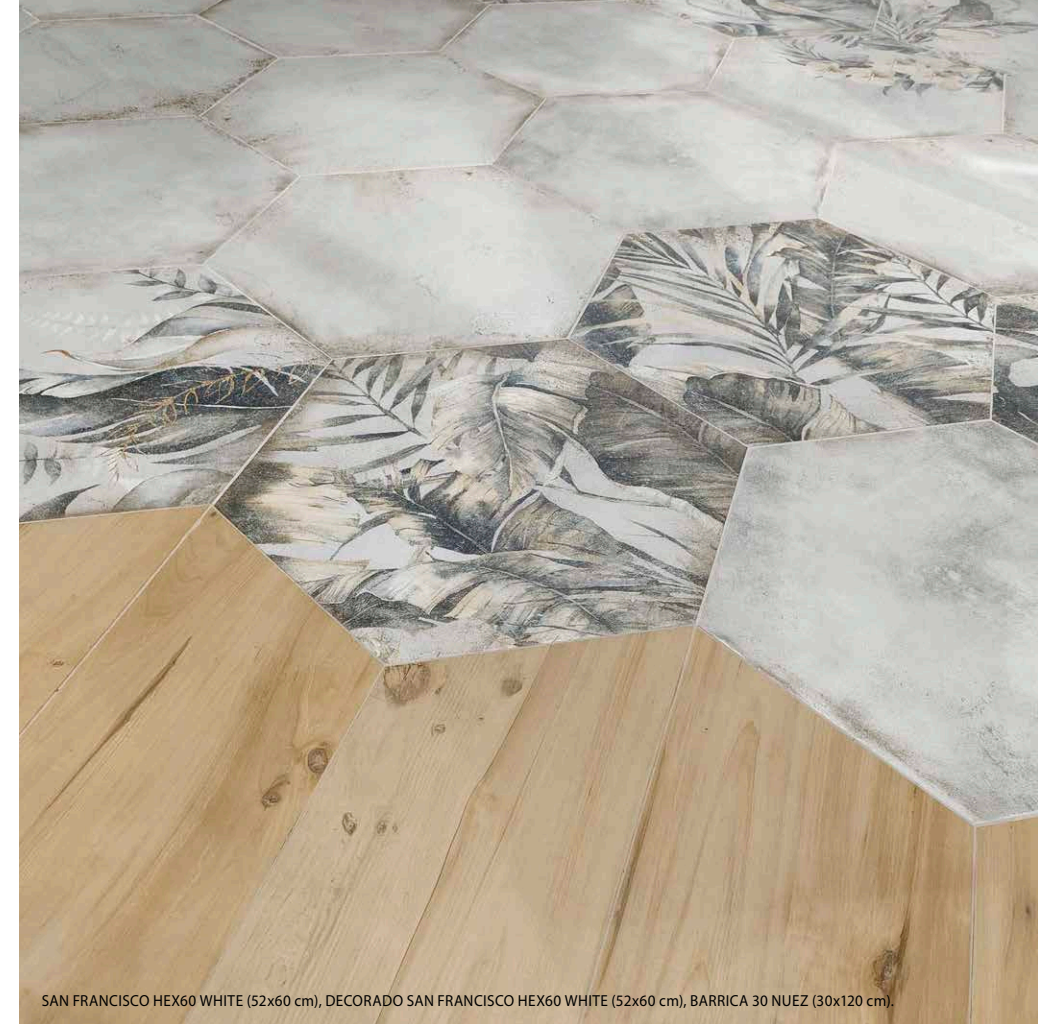

SAN FRANCISCO HEX60 WHITE (52x60 cm), DECORADO SAN FRANCISCO HEX60 WHITE (52x60 cm), BARRICA 30 NUEZ (30x120 cm).

**| PIEZAS DECORATIVAS · DECORATIVE PIECES |**

DECORADO SAN FRANCISCO HEX60 | 52x60 cm | **B14**

Ocho piezas diferentes. Unidad de venta: 1 caja. - Eight different pieces. Sales unit: 1 box



WHITE





wall: SAN FRANCISCO 3060 WHITE (30x60 cm), MOSAICO SAN FRANCISCO TS WHITE (30x30 cm).  
floor: SAN FRANCISCO 60 WHITE (60x60 cm).

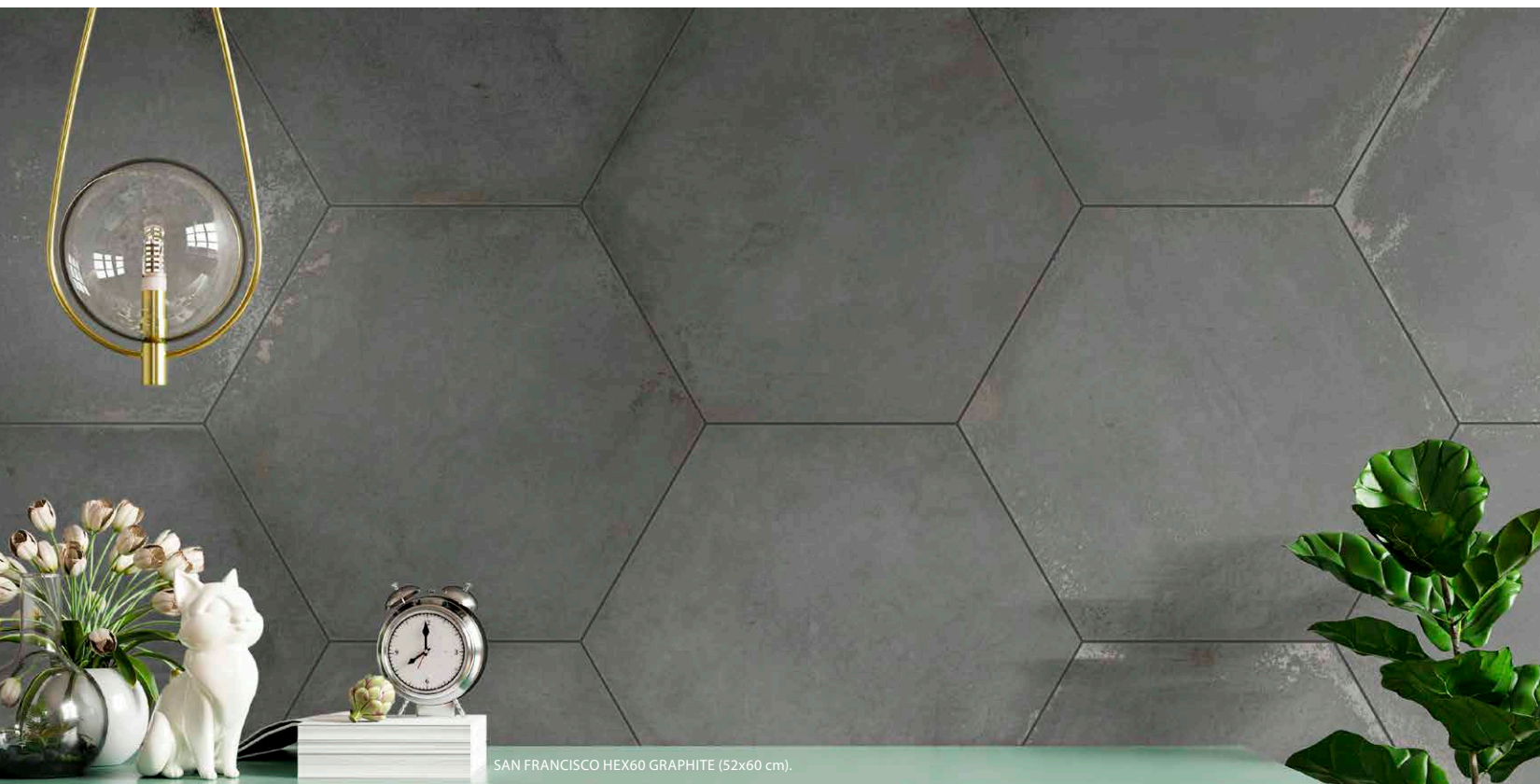

SAN FRANCISCO HEX60 GRAPHITE (52x60 cm).

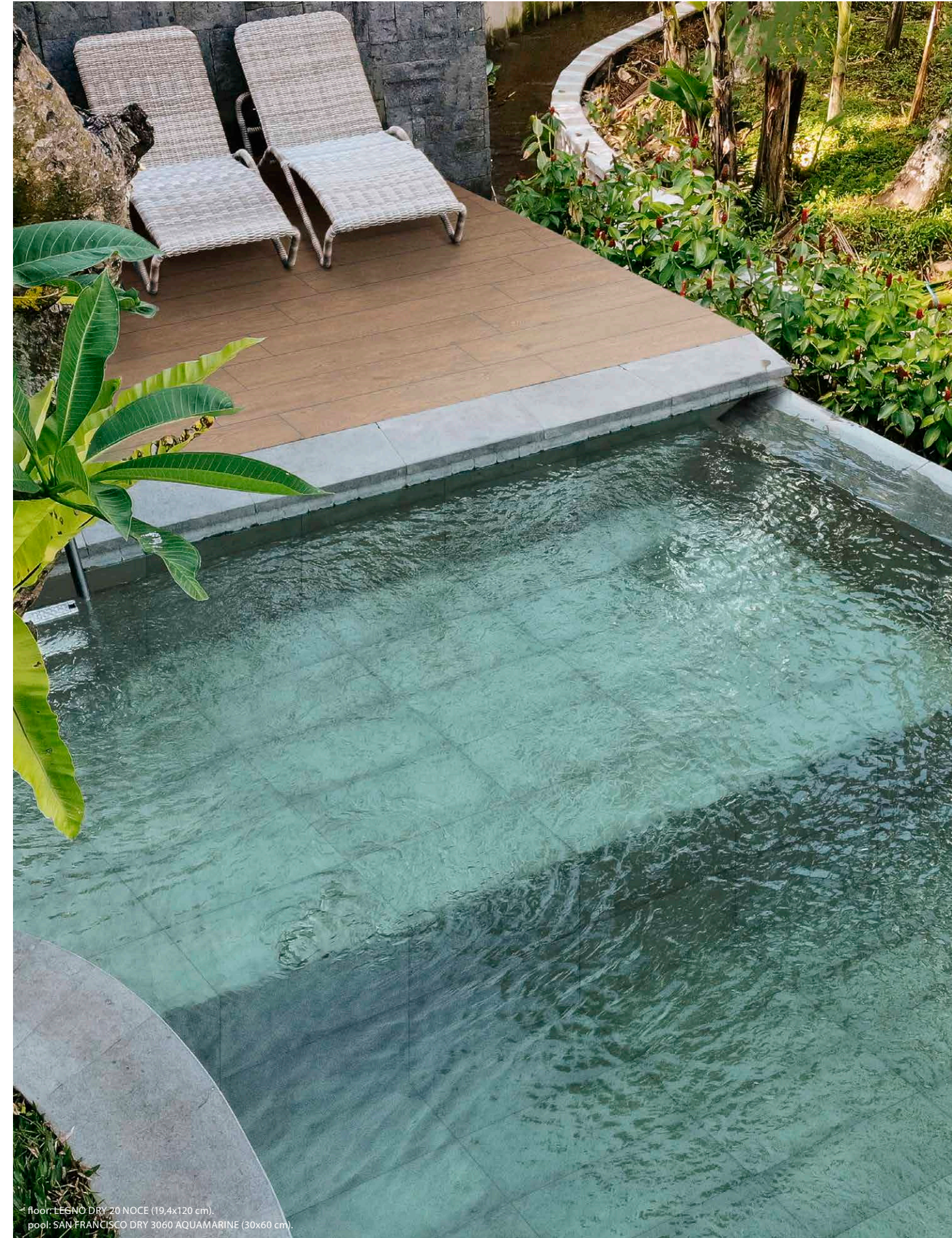

floor: LEGNO DRY 20 NOCE (19,4x120 cm).  
pool: SAN FRANCISCO DRY 3060 AQUAMARINE (30x60 cm).





urban furniture: STREET 120 WHITE (60x120cm).  
floor: DISTRICT 9090 ASH (90x90cm), DISTRICT DRY 9090 ASH (90x90cm).



# STONECRETE DISTRICT collection

| PORCELÁNICO · PORCELAIN | RECTIFICADO · RECTIFIED | DESTONIFICADO V3 · DESTONIFIED V3 |

[ESCALA DE LA GRÁFICA 1/2 - GRAPHIC SCALE 1/2]

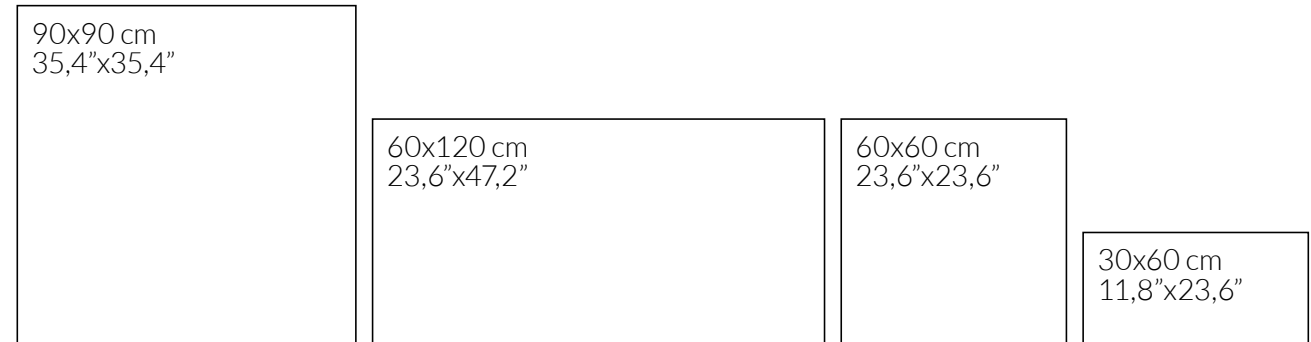

FORMATOS DISPONIBLES AVAILABLE FORMATS	ACABADO NATURAL · NATURAL FINISH	ACABADO ANTIDESLIZANTE · SLIP RESISTANCE FINISH
90x90 cm · 35,4" x 35,4"	DISTRICT 9090   B50	DISTRICT DRY 9090   B51 (sand, ash)
60x120 cm · 23,6" x 47,2"	DISTRICT 120   B85	DISTRICT DRY 120   B86 (sand, ash)
60x60 cm · 23,6" x 23,6"	DISTRICT 60   B35	DISTRICT DRY 60   B36 (sand, ash)
30x60 cm · 11,8" x 23,6"	DISTRICT 3060   B35	---

TAMAÑO DEL LIENZO: DOS LIENZOS 133x360 cm · GRAPHIC CHART SIZE: TWO GRAPHIC CHARTS 52,4" x 141,7"



SAND

WHITE

ASH

[COLORES DISPONIBLES - AVAILABLE COLORS]





wall: DISTRICT 120 ASH (60x120cm), DECORADO CHLOE R90 (30x90 cm), CEMENT R90 WHITE (30x90 cm), SLATS LEGNO 120 ROVERE (18,5x120 cm).  
 floor: DISTRICT 120 ASH (60x120cm).

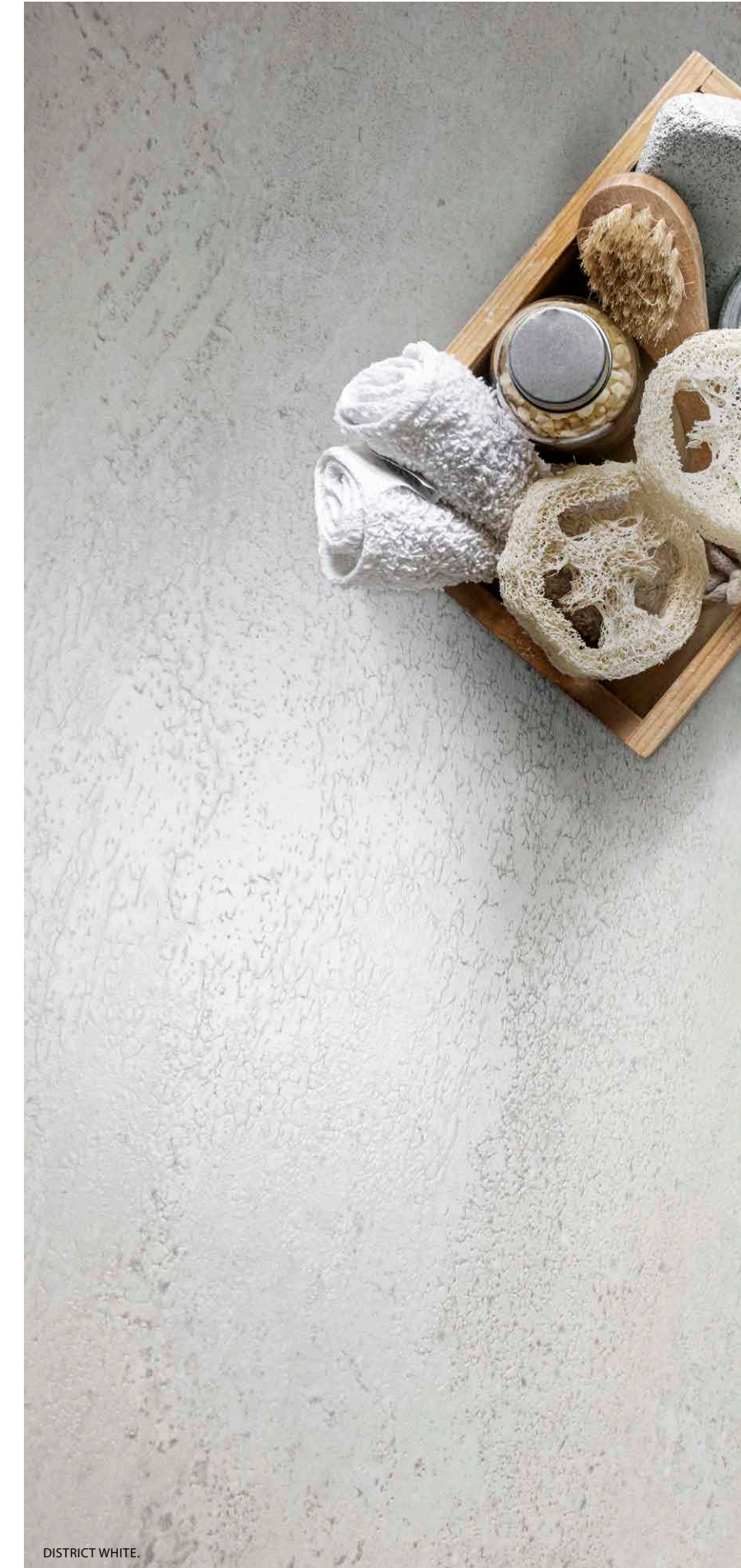

DISTRICT WHITE.





floor: STREET DRY 120 SAND (60x120 cm).

# STONECRETE STREET collection

| PORCELÁNICO · PORCELAIN | RECTIFICADO · RECTIFIED | DESTONIFICADO V3 · DESTONIFIED V3 |

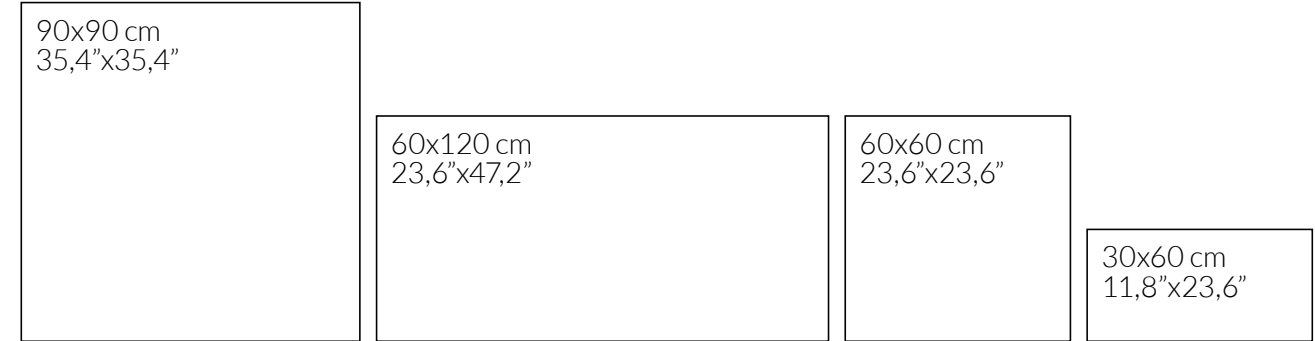

FORMATOS DISPONIBLES AVAILABLE FORMATS	ACABADO NATURAL · NATURAL FINISH 	ACABADO ANTIDESLIZANTE · SLIP RESISTANCE FINISH 
90x90 cm · 35,4"x35,4"	STREET 9090   B50	STREET DRY 9090   B51 (sand, ash)
60x120 cm · 23,6"x47,2"	STREET 120   B85	STREET DRY 120   B86 (sand, ash)
60x60 cm · 23,6"x23,6"	STREET 60   B35	STREET DRY 60   B36 (sand, ash)
30x60 cm · 11,8"x23,6"	STREET 3060   B35	---
29,7x34,5 cm · 11,7"x13,6"	STONECRETE MOSAIC HEX TULUM   P18  (sand)	---
	STONECRETE MOSAIC HEX RIALTO   P18  (white)	---
25x25 cm · 9,8"x9,8"	STONECRETE MOSAIC BRICK VENEZIA   P19  (sand)	---
	STONECRETE MOSAIC BRICK AGATA   P19  (ash)	---
TAMAÑO DEL LIENZO: DOS LIENZOS 133x360 cm · GRAPHIC CHART SIZE: TWO GRAPHIC CHARTS 52,4"x141,7"		

| PIEZAS DECORATIVAS · DECORATIVE PIECES |

STONECRETE MOSAIC HEX TULUM  
| 29,7x34,5 cm | P18



SAND

STONECRETE MOSAIC HEX RIALTO  
| 29,7x34,5 cm | P18

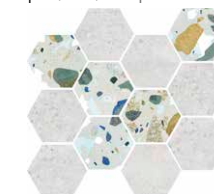

WHITE

STONECRETE MOSAIC BRICK VENEZIA  
| 25x25 cm | P19

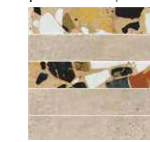

SAND

STONECRETE MOSAIC BRICK AGATA  
| 25x25 cm | P19



ASH



SAND



WHITE



ASH

| COLORES DISPONIBLES · AVAILABLE COLORS |





wall: STREET 120 SAND (60x120cm), FAME LUX 120 WHITE (60x120cm).  
floor: STREET 120 SAND (60x120cm).





wall: DISTRICT 120 WHITE (60x120cm).  
floor: STREET 9890 ASH (90x90cm).



wall and floor: STREET 120 ASH (60x120 cm).



STREET ASH.





wall and floor: STUDIO 120 CREAM (60x120 cm).

# STUDIO collection

| PORCELÁNICO · PORCELAIN | RECTIFICADO · RECTIFIED | DESTONIFICADO V3 · DESTONIFIED V3 |

ESCALA DE LA GRÁFICA 1/2 - GRAPHIC SCALE 1/21

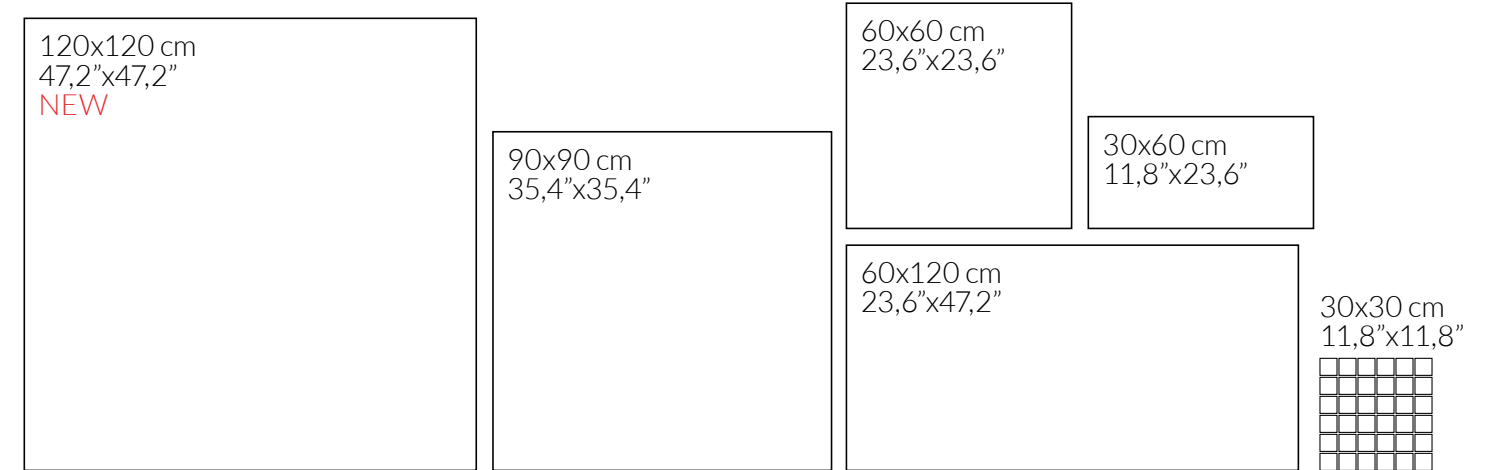

FORMATOS DISPONIBLES AVAILABLE FORMATS	ACABADO NATURAL NATURAL FINISH 	ACABADO ANTIDESLIZANTE SLIP RESISTANCE FINISH 	ACABADO LAPADO BRILLO GLOSSY LAPATTO FINISH 
120x120 cm · 47,2"x47,2"	STUDIO 120x120   B04 (cream, white, grey, ash)	STUDIO DRY 120x120   B11 (cream, ash)	---
90x90 cm · 35,4"x35,4"	STUDIO 9090   B50	STUDIO DRY 9090   B51 (cream, white, ash)	---
60x120 cm · 23,6"x47,2"	STUDIO 120   B85	STUDIO DRY 120   B86	STUDIO LUX 120   B83
60x60 cm · 23,6"x23,6"	STUDIO 60   B35	STUDIO DRY 60   B36	STUDIO LUX 60   B37
30x60 cm · 11,8"x23,6"	STUDIO 3060   B35	STUDIO DRY 3060   B36	STUDIO LUX 3060   B37
30x30 cm · 11,8"x11,8"	MOSAICO STUDIO T5   P70 	---	---
TAMAÑO DEL LIENZO: 175x340 cm · GRAPHIC CHART SIZE: 68,9"x133,9"			



COLORES DISPONIBLES - AVAILABLE COLOURS





floor: STUDIO LUX 60 ASH (60x60 cm).



floor: STUDIO DRY 120x120 ASH (120x120 cm), STUDIO 120x120 ASH (120x120 cm).



wall: STUDIO 3060 WHITE Y ASH (30x60cm), MOSAICO STUDIO T5 GREY (30x30 cm).  
floor: STUDIO 60 GREY (60x60cm).





wall: STUDIO R90 WHITE Y ASH (30x90 cm), DECORADO STUDIO R90 (30x90 cm).  
floor: STUDIO 60 WHITE (60x60 cm).

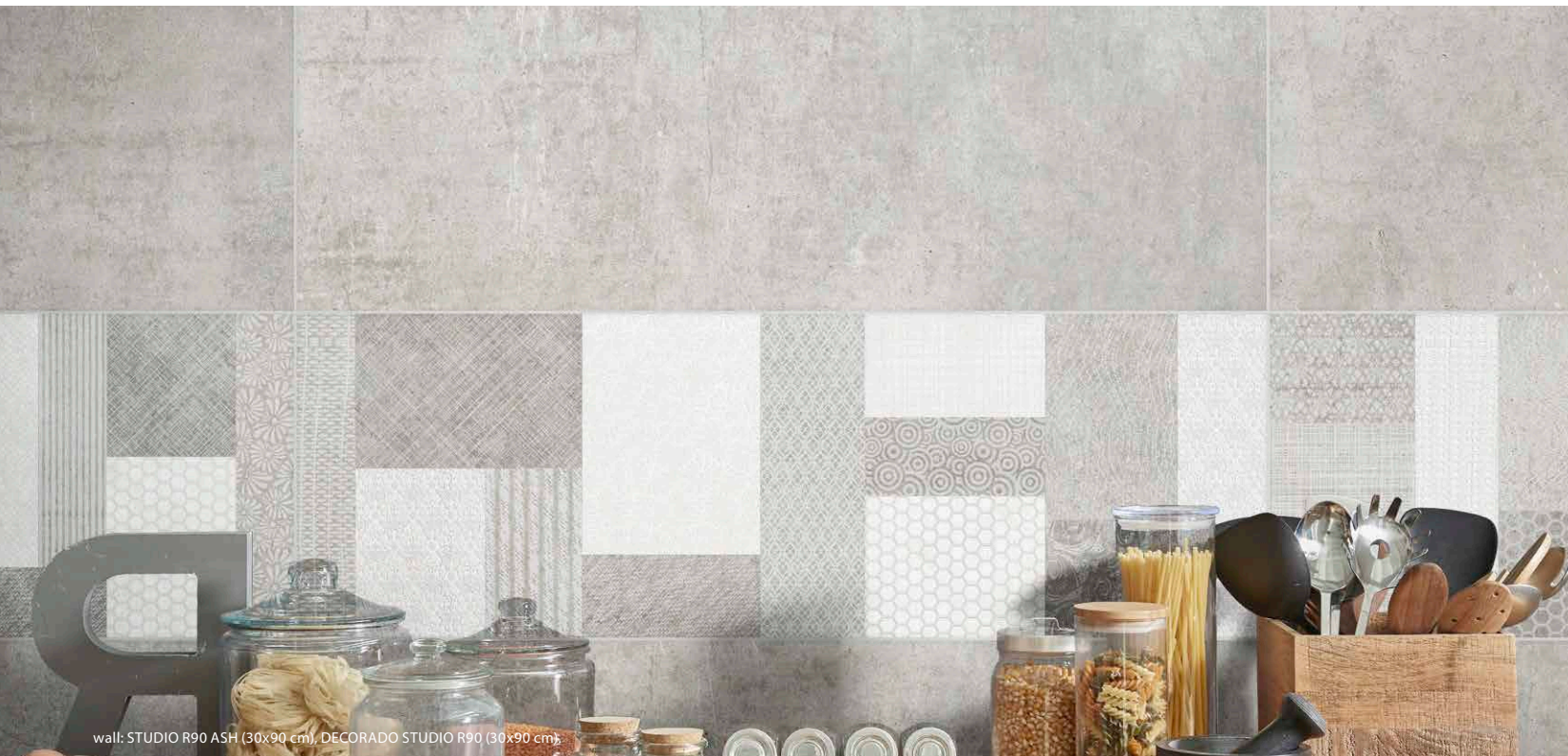

wall: STUDIO R90 ASH (30x90 cm), DECORADO STUDIO R90 (30x90 cm).

| PIEZAS DECORATIVAS · DECORATIVE PIECES |

DECORADO SYDNEY R3060 RECT. | 30x60 cm | B67

Tres piezas diferentes. Unidad de venta: 1 caja. - Three different pieces. Sales unit: 1 box.



STUDIO R3060 RECT. SLIP | 30x60 cm | B67



WHITE



ASH

DECORADO STUDIO R90 | 30x90 cm | B44

Dos piezas diferentes. Unidad de venta: 1 caja. - Two different pieces. Sales unit: 1 box.



DECORADO SYDNEY R90 | 30x90 cm | B44

Tres piezas diferentes. Unidad de venta: 1 caja. - Three different pieces. Sales unit: 1 box.

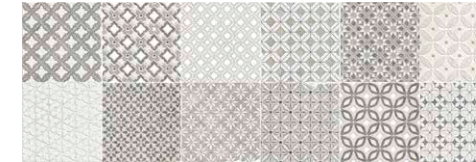

STUDIO R90 SLIP | 30x90 cm | B43



WHITE



ASH



GRAPHITE

# STUDIO collection

| PASTA BLANCA · WHITE BODY |  
| RECTIFICADO · RECTIFIED |  
| DESTONIFICADO V3 · DESTONIFIED V3 |

30x90 cm  
11,8"x35,4"

30x60 cm  
11,8"x23,6"

FORMATOS DISPONIBLES AVAILABLE FORMATS	ACABADO MATE · MATT FINISH
30x90 cm - 11,8"x35,4"	STUDIO R90   B42
	DECORADO STUDIO R90   B44
	DECORADO SYDNEY R90   B44
30x60 cm - 11,8"x23,6"	STUDIO R90 SLIP   B43
	STUDIO R3060 RECT.   B65 (white, ash)
	DECORADO SYDNEY R3060 RECT.   B67
TAMAÑO DEL LIENZO: 175x340 cm · GRAPHIC CHART SIZE: 68,9"x133,9"	



WHITE

ASH

GRAPHITE





wall: STUDIO R3060 RECT. SLIP ASH (30x60 cm).  
floor: STUDIO LUX 60 ASH (60x60 cm).



wall: STUDIO R90 WHITE (30x90 cm), DECORADO SYDNEY R90 (30x90 cm).  
floor: STUDIO 60 GRAPHITE (60x60 cm).





**COLOR | COLOR**

ANGORA - <b>NEW</b>	74 - 77
HERITAGE	78 - 79
KALEIDOSCOPE - <b>NEW</b>	80 - 83
SENSE	84 - 89
VIENA	90 - 91
WHITE - <b>NEW</b>	92 - 97

**AZTECA**





wall: DECORADO AZAI R90 GREY (30x90 cm).



wall: DECORADO AZAI R90 WHITE (30x90 cm).

# ANGORA<sub>collection</sub>

| PASTA BLANCA · WHITE BODY | RECTIFICADO · RECTIFIED | DESTONIFICADO V1 · DESTONIFIED V1 |

| ESCALA DE LA GRÁFICA 1/2 · GRAPHIC SCALE 1/2 |

**| PIEZAS DECORATIVAS · DECORATIVE PIECES |**

DECORADO ALANI R90 | 30x90 cm | **B43**

Tres piezas diferentes. Unidad de venta: 1 caja. Three different pieces. Sales unit: 1 box.



WHITE



DECORADO AZAI R90 | 30x90 cm | **B44**

SAND

WHITE

GREY

30x90 cm  
11,8" x 35,4"

FORMATOS DISPONIBLES AVAILABLE FORMATS	ACABADO MATE · MATT FINISH 
	ANGORA R90   B42
30x90 cm · 11,8" x 35,4"	DECORADO ALANI R90   B43 → (white)
	DECORADO AZAI R90   B44  →

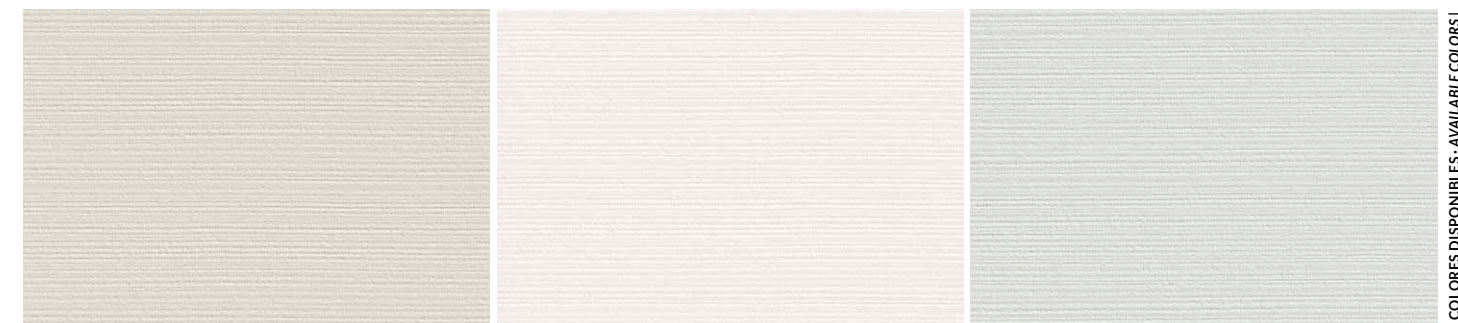

SAND

WHITE

GREY

| COLORES DISPONIBLES · AVAILABLE COLORS |





wall: DECORADO ALANI R90 WHITE (30x90 cm), ANGORA R90 WHITE Y SAND (30x90 cm).  
 floor: SANTANYI 120 BEIGE (60x120 cm).



wall: DECORADO ALANI R90 WHITE (30x90 cm).





wall: HERITAGE R90 GREEN Y WHITE (30x90 cm).  
floor: BALI LUX 60 WHITE (60x60 cm).

# HERITAGE collection

| PASTA BLANCA · WHITE BODY | RECTIFICADO · RECTIFIED | DESTONIFICADO V2 · DESTONIFIED V2 |

**| PIEZAS · PIECES |**

HERITAGE R90 | 30x90 cm | B44



GREEN

Rejunte recomendado Caramelo. - Recommended grouting Caramelo.



WHITE

Rejunte recomendado Manhattan. - Recommended grouting Manhattan.



BLUE

Rejunte recomendado Cement. - Recommended grouting Cement.

30x90 cm  
11,8"x35,4"

<p>FORMATOS DISPONIBLES AVAILABLE FORMATS</p>	<p>ACABADO MATE MATT FINISH</p>
<p>30x90 cm · 11,8"x35,4"</p>	<p>HERITAGE R90   B44</p>
<p>Nº DISEÑOS POR FORMATO · Nº DESIGNS BY FORMAT:   30x90: 4  </p>	



HERITAGE R90 WHITE (30x90 cm).



wall: HERITAGE R90 BLUE (30x90 cm), BARRICA 30 BONE (30x120 cm).  
floor: BARRICA 30 BONE (30x120 cm).

COLORES DISPONIBLES · AVAILABLE COLORS





wall: KALEIDOSCOPE 120 CREAM Y WHITE (60x120 cm).  
floor: KALEIDOSCOPE 120 TAUPE (60x120 cm).



wall: KALEIDOSCOPE 120 WHITE (60x120 cm).  
floor: KALEIDOSCOPE 120 TAUPE (60x120 cm).

# KALEIDOSCOPE collection

| PORCELÁNICO · PORCELAIN | RECTIFICADO · RECTIFIED | DESTONIFICADO V1 · DESTONIFIED V1 |

| ESCALA DE LA GRÁFICA 1/2 · GRAPHIC SCALE 1/2 |

**| PIEZAS DECORATIVAS · DECORATIVE PIECES |**

KALEIDOSCOPE MOSAIC BRICK ORO | 25x25 cm | **P19**

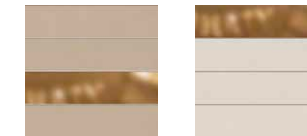

TAUPE WHITE

KALEIDOSCOPE MOSAIC HEX TILIA | 29,7x34,5 cm | **P18**



TAUPE WHITE

DECORADO TILIA 120 | 60x120 cm | **P92**

Formado por dos piezas. Prestar atención a la continuidad del diseño durante la colocación. Unidad de venta: 1 caja.  
Set of two matching pieces. Please pay attention to design ongoing graphic during tile installation. Sales unit: 1 box.



TAUPE



WHITE



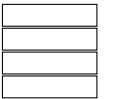



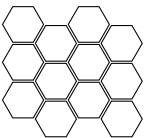

25x25 cm  
9,8"x9,8"



29,7x34,5 cm  
11,7"x13,6"



60x120 cm  
23,6"x47,2"

FORMATOS DISPONIBLES AVAILABLE FORMATS	ACABADO NATURAL NATURAL FINISH  
60x120 cm · 23,6"x47,2"	KALEIDOSCOPE 120   B85  DECORADO TILIA 120   P92   (taupe, white)
29,7x34,5 cm · 11,7"x13,6"	KALEIDOSCOPE MOSAIC HEX TILIA   P18   (taupe, white)
25x25 cm · 9,8"x9,8"	KALEIDOSCOPE MOSAIC BRICK ORO   P19   (taupe, white)
TAMAÑO DEL LIENZO: 100x300 cm · GRAPHIC CHART SIZE: 39,4"x118,1"	

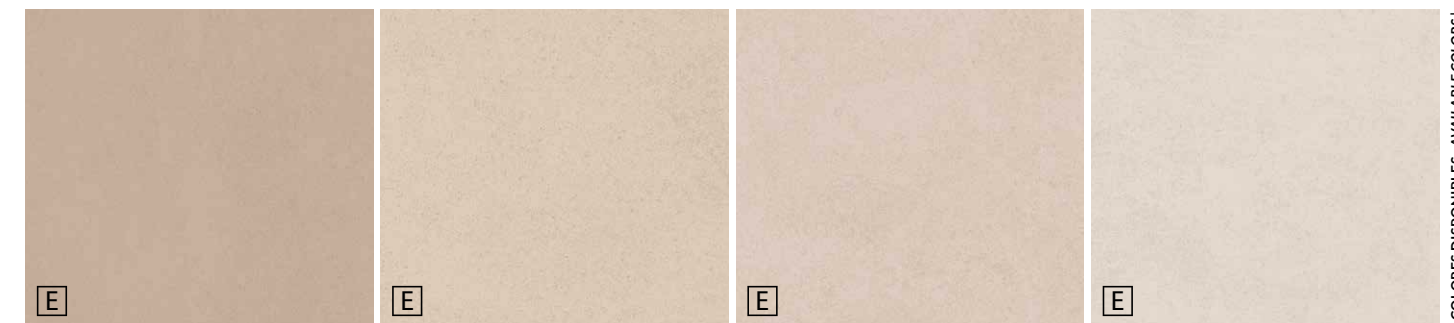

TAUPE

CREAM

OFF WHITE

WHITE

| COLORES DISPONIBLES · AVAILABLE COLORS |





wall: KALEIDOSCOPE 120 TAUPE Y WHITE (60x120 cm), TURQUETA 5x15 SALVIA MATT (5x15 cm).  
floor: KALEIDOSCOPE 120 WHITE (60x120 cm).





wall: SENSE R90 GREY (30x90 cm), DECORADO STRIPE R90 GREY (30x90 cm).  
floor: KAI 60 ASH (60x60 cm).

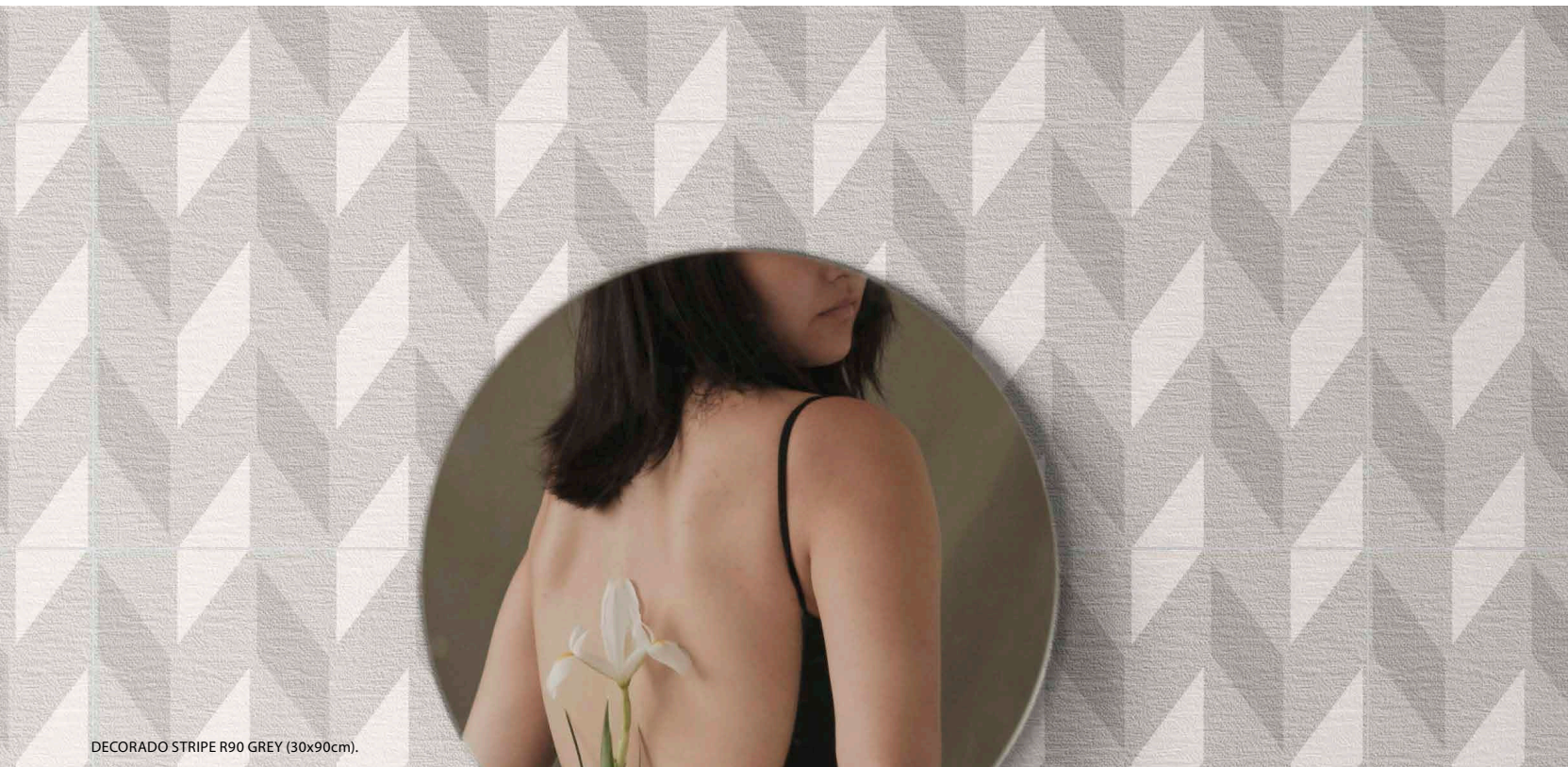

DECORADO STRIPE R90 GREY (30x90cm).

# SENSE collection

| PASTA BLANCA · WHITE BODY | RECTIFICADO · RECTIFIED | DESTONIFICADO V1 · DESTONIFIED V1 |

| ESCALA DE LA GRÁFICA 1/2 · GRAPHIC SCALE 1/2 |

## | PIEZAS DECORATIVAS · DECORATIVE PIECES |

SENSE R90 SKY | 30x90 cm | B43



BLUE



WHITE

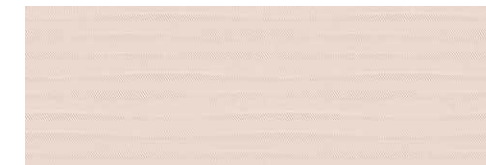

ROSE

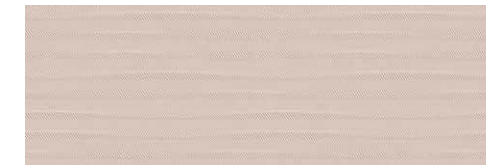

TERRA

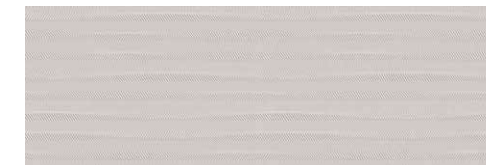

GREY

DECORADO SENDAI R90 | 30x90 cm | B43

Tres piezas diferentes. Unidad de venta: 1 caja. Three different pieces. Sales unit: 1 box.



WHITE

30x90 cm  
11,8"x35,4"

FORMATOS DISPONIBLES AVAILABLE FORMATS	ACABADO MATE · MATT FINISH 
	SENSE R90   B42
	SENSE R90 SKY   B43 
	DECORADO STRIPE R90   B43
	DECORADO SENDAI R90   B43 
30x90 cm · 11,8"x35,4"	MOSAICO SENDAI HEX   P15 

DECORADO STRIPE R90 | 30x90 cm | B43



TERRA



GREY

MOSAICO SENDAI HEX | 29,3x25,4 cm | P15



WHITE



TERRA

ROSE

WHITE

BLUE

GREY

| COLORES DISPONIBLES · AVAILABLE COLORS |





wall: SENSE R90 WHITE (30x90 cm), SENSE R90 SKY WHITE (30x90 cm), DECORADO STRIPE R90 TERRA (30x90 cm)  
 floor: BARRICA 20 Y 30 NUEZ (19,4x120 y 30x120 cm).



SENSE R90 SKY GREY (30x90cm).





DECORADO SENDAI R90 WHITE (30x90 cm).



wall: SENSE R90 WHITE (30x90 cm), DECORADO SENDAI R90 WHITE (30x90 cm), SENSE R90 SKY WHITE (30x90 cm).  
 floor: BELLVER 60 GREY (60x60 cm).





wall: VIENA R120 WHITE (40x120 cm), DECORADO VIENA R120 WHITE (40x120 cm).  
floor: BARRICA 30 MIEL (30x120 cm).



DECORADO VIENA R120 WHITE (40x120cm).

# VIENA<sup>collection</sup>

| PASTA BLANCA · WHITE BODY |  
| RECTIFICADO · RECTIFIED |  
| DESTONIFICADO V1 · DESTONIFIED V1 |

40x120 cm  
15,7"x47,2"

FORMATOS DISPONIBLES AVAILABLE FORMATS	ACABADO MATE · MATT FINISH 
40x120 cm · 15,7"x47,2"	VIENA R120   B94
	DECORADO VIENA R120   B95 

### | PIEZAS DECORATIVAS · DECORATIVE PIECES |

DECORADO VIENA R120 | 40x120 cm | B95

Cuatro piezas diferentes. Unidad de venta: 1 caja. Four different pieces. Sales unit: 1 box.



WHITE

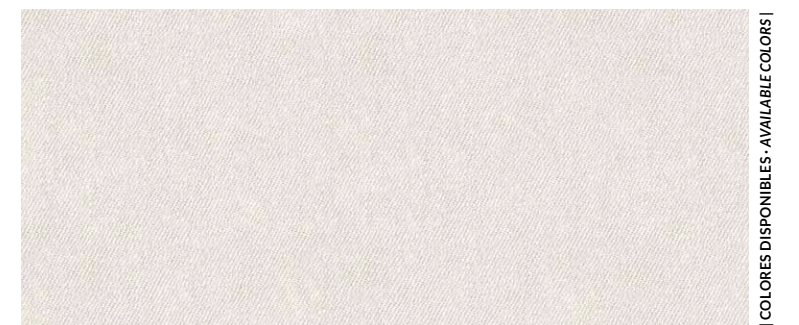

WHITE

| COLORES DISPONIBLES · AVAILABLE COLORS |





wall: DECORADO 2 GARDEN R90 WHITE (30x90 cm), UNIK R90 WHITE GLOSSY (30x90 cm).  
 floor: ORION SCINTILLANTE 60 TITANIUM (60x60 cm).



















# WHITE collection

| PASTA BLANCA · WHITE BODY | RECTIFICADO · RECTIFIED | DESTONIFICADO V1 · DESTONIFIED V1 |

40x120 cm  
15,7"x47,2"

30x90 cm  
11,8"x35,4"

30x60 cm  
11,8"x23,6"

FORMATOS DISPONIBLES AVAILABLE FORMATS	ACABADO MATE · MATT FINISH  	ACABADO BRILLO · GLOSSY FINISH  
40x120 cm · 15,7"x47,2"	UNIK R120 WHITE MATT   B93	UNIK R120 WHITE GLOSSY   B96
	UNIK R120 QUEEN WHITE MATT   B95 	UNIK R120 QUEEN WHITE GLOSSY   B98 
30x90 cm · 11,8"x35,4"	UNIK R90 WHITE MATT   B40	UNIK R90 WHITE GLOSSY   B40 UNIK R90 BLACK GLOSSY   B41
	UNIK R90 JUNGLE WHITE SHADOW   B44  	UNIK R90 JUNGLE WHITE SHINY   B44  
	UNIK R90 FROST WHITE MATT   B43 	UNIK R90 FROST WHITE GLOSSY   B43 
	UNIK R90 BUBBLES WHITE MATT   B43 	UNIK R90 BUBBLES BLACK GLOSSY   B43 UNIK R90 BUBBLES WHITE GLOSSY   B43 
	UNIK R90 VIBE WHITE MATT   B43 	UNIK R90 VIBE WHITE GLOSSY   B43 
	---	UNIK R90 DUNES WHITE GLOSSY   B43 
	KEYWEST R90 WHITE   B42 	---
	---	BEAUTY R90 WHITE   B43  
30x60 cm · 11,8"x23,6"	UNIK R3060 RECT. WHITE MATT   B25	UNIK R3060 RECT. WHITE GLOSSY   B25



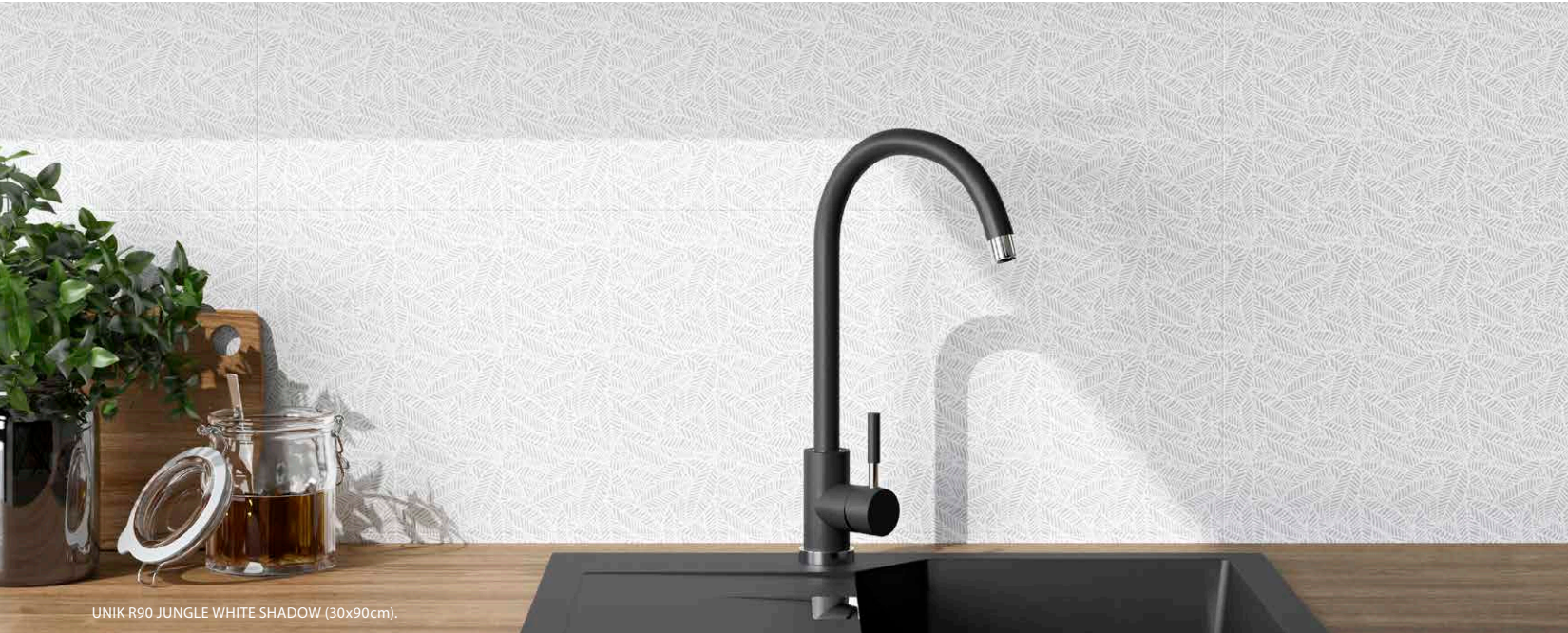

UNIK R90 JUNGLE WHITE SHADOW (30x90cm).



wall: UNIK R120 QUEEN WHITE MATT (40x120 cm), BARRICA 20 MIEL (19,4x120 cm), KAI 120 ASH (60x120 cm),  
floor: KAI 120 ASH (60x120 cm), BARRICA DRY 20 MIEL (19,4x120 cm).

UNIK R90 WHITE MATT | 30x90 cm | **B40**  
UNIK R90 WHITE GLOSSY | 30x90 cm | **B40**



UNIK R90 BUBBLES WHITE MATT | 30x90 cm | **B43**  
UNIK R90 BUBBLES WHITE GLOSSY | 30x90 cm | **B43**



UNIK R90 FROST WHITE MATT | 30x90 cm | **B43**  
UNIK R90 FROST WHITE GLOSSY | 30x90 cm | **B43**



UNIK R90 DUNES WHITE GLOSSY | 30x90 cm | **B43**

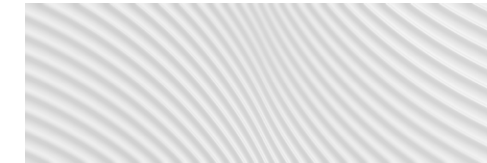

BEAUTY R90 WHITE | 30x90 cm | **B43**



UNIK R90 VIBE WHITE MATT | 30x90 cm | **B43**  
UNIK R90 VIBE WHITE GLOSSY | 30x90 cm | **B43**



UNIK R120 WHITE MATT | 40x120 cm | **B93**  
UNIK R120 WHITE GLOSSY | 40x120 cm | **B96**



UNIK R90 BLACK GLOSSY | 30x90 cm | **B41**



UNIK R90 BUBBLES BLACK GLOSSY | 30x90 cm | **B43**



KEYWEST R90 WHITE | 30x90 cm | **B42**



UNIK R90 JUNGLE WHITE SHADOW | 30x90 cm | **B44**



UNIK R90 JUNGLE WHITE SHINY | 30x90 cm | **B44**



UNIK R120 QUEEN WHITE MATT | 40x120 cm | **B95**  
UNIK R120 QUEEN WHITE GLOSSY | 40x120 cm | **B98**

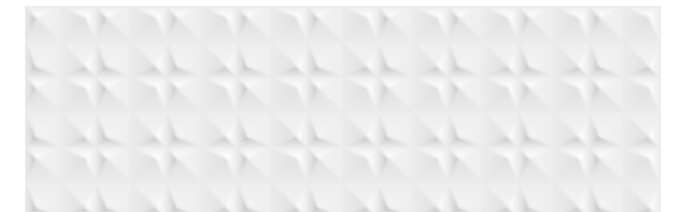





wall: UNIK R90 VIBE WHITE GLOSSY (30x90cm).



wall: UNIK R90 JUNGLE WHITE SHINY (30x90cm).



wall: BEAUTY R90 WHITE (30x90 cm), BARRICA 30 BONE (30x120 cm).  
floor: BARRICA 30 MIEL (30x120 cm).





**PIEDRA | STONE**

ANETO	100 - 103
ARMONY	104 - 105
BELLVER	106 - 111
BROOKLYN	112 - 115
DOMINO	116 - 117
GROUND	118 - 121
PORTOPETRO - NEW	122 - 127
SANTANYI - NEW	128 - 131
SEASTONE	132 - 135
SHELLSTONE - NEW	136 - 143
STONEAGE	144 - 149
TOSCANA	150 - 153





floor: ANETO DRY 60 SAND (60x60 cm).



wall: ANETO SOFT 120 DARK GREY (60x120 cm), DELHI 20 BONE (19,4x120 cm).  
floor: ANETO SOFT 120 DARK GREY (60x120 cm).

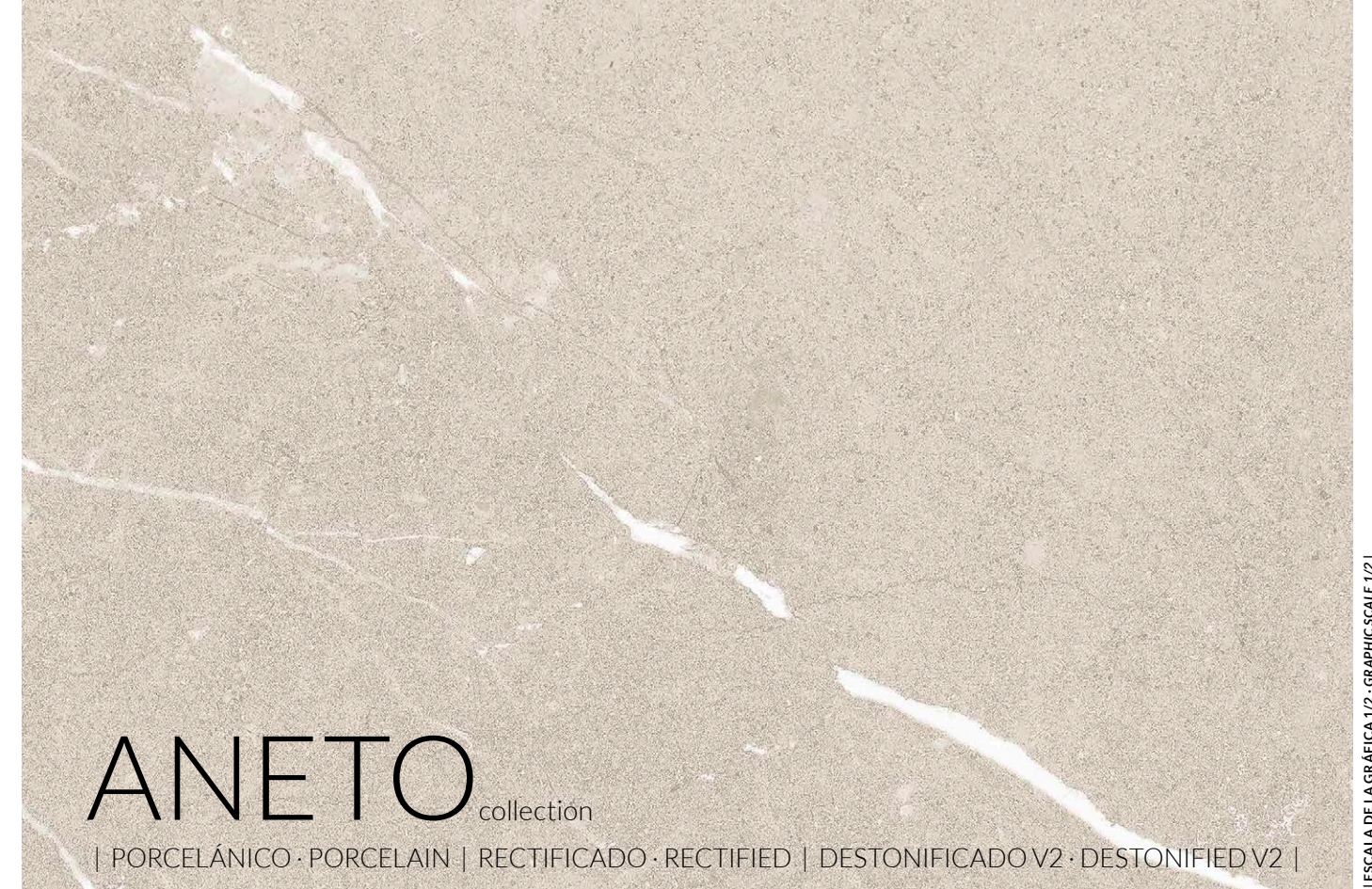

# ANETO

collection

| PORCELÁNICO · PORCELAIN | RECTIFICADO · RECTIFIED | DESTONIFICADO V2 · DESTONIFIED V2 |

ESCALA DE LA GRÁFICA 1/2 - GRAPHIC SCALE 1/2 |

60x120 cm  
23,6"x47,2"

60x60 cm  
23,6"x23,6"

30x60 cm  
11,8"x23,6"

FORMATOS DISPONIBLES AVAILABLE FORMATS	ACABADO LAPADO MATE MATT LAPATTO FINISH	ACABADO ANTIDESLIZANTE SLIP RESISTANCE FINISH
	 2 9 >0,42	 3 10 >0,61
60x120 cm · 23,6"x47,2"	ANETO SOFT 120   B83	ANETO DRY 120   B86
60x60 cm · 23,6"x23,6"	ANETO SOFT 60   B37	ANETO DRY 60   B36
30x60 cm · 11,8"x23,6"	ANETO SOFT 3060   B37	---
Nº DISEÑOS POR FORMATO · Nº DESIGNS BY FORMAT:   60x120: 8   60x60: 15   30x60: 30		



SAND

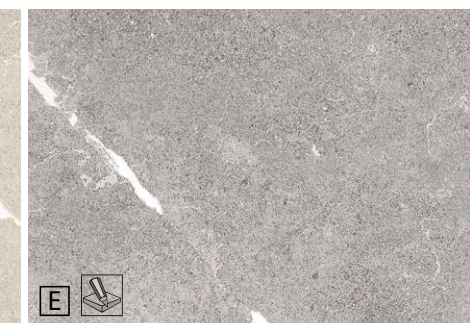

GREY

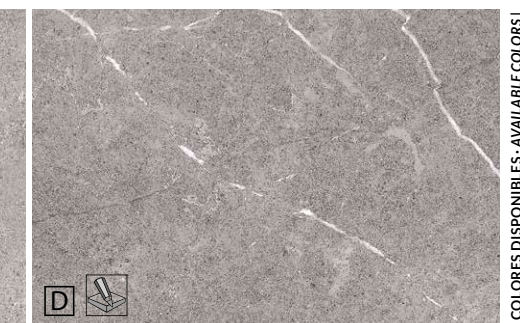

DARK GREY

COLORES DISPONIBLES · AVAILABLE COLORS |





wall: ANETO R3060 Rect. SAND (30x60 cm), ANETO R3060 Rect. WALL SAND (30x60 cm).  
floor: ANETO SOFT 60 SAND (60x60 cm).



ANETO R3060 RECT. WALL GREY (30x60cm).



# ANETO collection

| PASTA BLANCA · WHITE BODY | RECTIFICADO · RECTIFIED | DESTONIFICADO V2 · DESTONIFIED V2 |

| ESCALA DE LA GRÁFICA 1/2 · GRAPHIC SCALE 1/2 |

30x60 cm  
11,8"x23,6"

<p>FORMATOS DISPONIBLES AVAILABLE FORMATS</p>	<p>ACABADO MATE · MATT FINISH</p>
<p>30x60 cm · 11,8"x23,6"</p>	<p>ANETO R3060 RECT.   B65</p>
	<p>ANETO R3060 RECT. WALL   B67</p>
<p>Nº DISEÑOS POR FORMATO · Nº DESIGNS BY FORMAT:   30x60: 20  </p>	

### | PIEZAS DECORATIVAS · DECORATIVE PIECES |

ANETO R3060 RECT. WALL | 30x60 cm | B67



SAND



GREY



SAND



GREY

| COLORES DISPONIBLES · AVAILABLE COLORS |





wall: ARMONY R90 SNOW (30x90 cm), LEGNO R90 TRAIL ROVERE (30x90 cm).





wall: ARMONY R90 BONE (30x90 cm), ARMONY R90 DUNES BONE (30x90 cm).

# ARMONY collection

| PASTA BLANCA · WHITE BODY | RECTIFICADO · RECTIFIED | DESTONIFICADO V2 · DESTONIFIED V2 |

| ESCALA DE LA GRÁFICA 1/2 · GRAPHIC SCALE 1/2 |

30x90 cm  
11,8"x35,4"

FORMATOS DISPONIBLES AVAILABLE FORMATS	ACABADO MATE · MATT FINISH 
30x90 cm · 11,8"x35,4"	ARMONY R90   B42
	ARMONY R90 DUNES   B43 
TAMAÑO DEL LIENZO: 95x183 cm · GRAPHIC CHART SIZE: 37,4"x72"	

| PIEZAS DECORATIVAS · DECORATIVE PIECES |

ARMONY R90 DUNES | 30x90 cm | B43

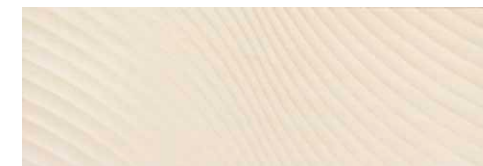

BONE



SNOW

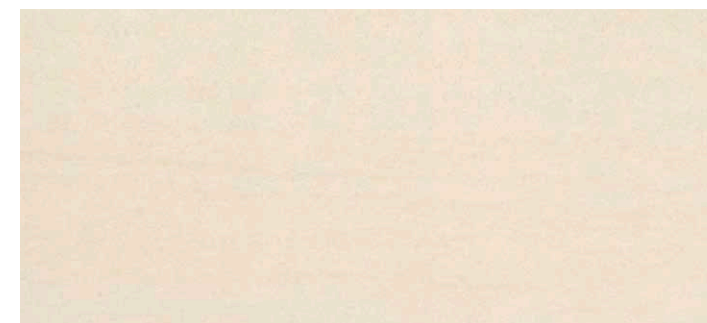

BONE

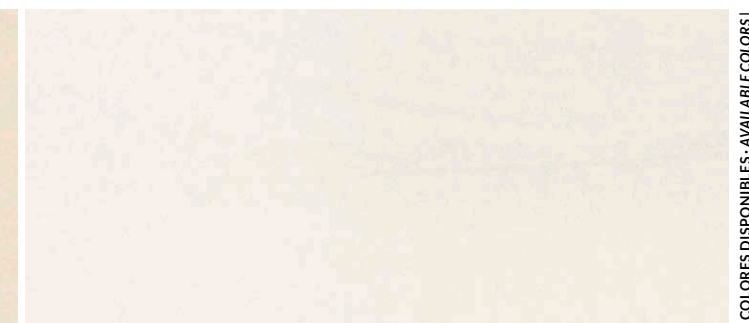

SNOW

| COLORES DISPONIBLES · AVAILABLE COLORS |





floor: BELLVER 9090 IVORY (90x90 cm)



# BELLVER collection

| PORCELÁNICO · PORCELAIN | RECTIFICADO · RECTIFIED | DESTONIFICADO V2 · DESTONIFIED V2 |

ESCALA DE LA GRÁFICA 1/2 · GRAPHIC SCALE 1/2 |

90x90 cm 35,4"x35,4"	60x120 cm 23,6"x47,2"	60x60 cm 23,6"x23,6"	30x30 cm 11,8"x11,8"	29,8x26,2 cm 11,7"x10,3"
			30x60 cm 11,8"x23,6"	

FORMATOS DISPONIBLES AVAILABLE FORMATS	ACABADO NATURAL · NATURAL FINISH 	ACABADO ANTIDESLIZANTE · SLIP RESISTANCE FINISH 
90x90 cm · 35,4"x35,4"	BELLVER 9090   B50	BELLVER DRY 9090   B51
60x120 cm · 23,6"x47,2"	BELLVER 120   B85	BELLVER DRY 120   B86
	BELLVER 120 BLOSSOM   B70  (sand, ivory, grey)	---
	BELLVER 120 PLANE   B70  (sand, ivory)	---
60x60 cm · 23,6"x23,6"	BELLVER 60   B35	BELLVER DRY 60   B36
30x60 cm · 11,8"x23,6"	BELLVER 3060   B35	BELLVER DRY 3060   B36
30x30 cm · 11,8"x11,8"	MOSAICO BELLVER T5   P70	---
29,8x26,2 cm · 11,7"x10,3"	MOSAICO BELLVER MURETTO   P12	---

TAMAÑO DEL LIENZO: 147,8x300 cm · GRAPHIC CHART SIZE: 58,2"x118,1"

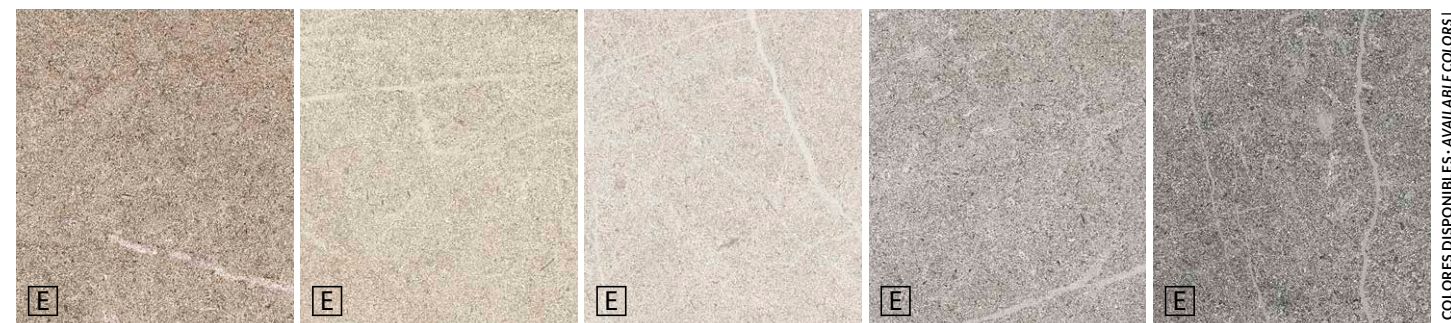

GREIGE SAND IVORY GREY DARK GREY

COLORES DISPONIBLES · AVAILABLE COLORS |





wall: BELLVER 120 PLANE IVORY (60x120 cm), BELLVER 120 IVORY (60x120 cm).  
 floor: BELLVER 120 GREIGE (60x120 cm), BELLVER DRY 120 GREIGE (60x120 cm).

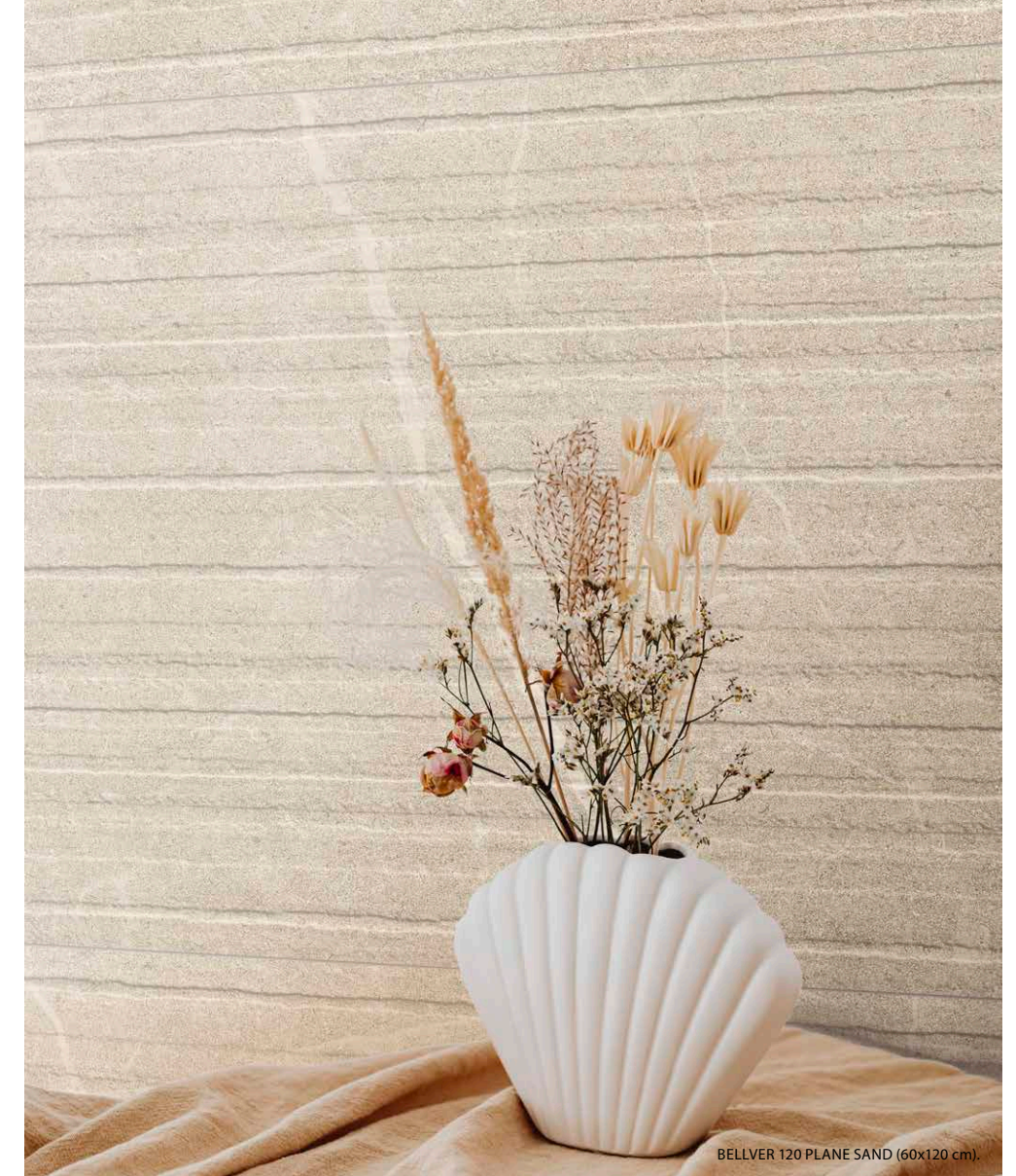

BELLVER 120 PLANE SAND (60x120 cm).

| PIEZAS DECORATIVAS · DECORATIVE PIECES |

BELLVER 120 PLANE | 60x120 cm | B70



SAND



IVORY





wall: BELLVER 120 GREY Y DARK GREY (60x120 cm) BELLVER 120 BLOSSOM GREY (60x120 cm), MOSAICO BELLVER MURETTO GREY (29,8x26,2 cm).  
 floor: BELLVER 120 DARK GREY (60x120 cm).



BELLVER 120 BLOSSOM SAND (60x120cm).

| PIEZAS DECORATIVAS · DECORATIVE PIECES |

BELLVER 120 BLOSSOM | 60x120 cm | B70



SAND



IVORY

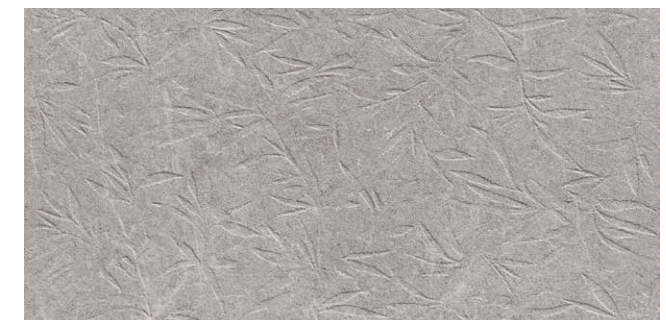

GREY





wall and floor: BROOKLYN LUX 9090 CREAM (90x90 cm).



# BROOKLYN collection

| PORCELÁNICO · PORCELAIN | RECTIFICADO · RECTIFIED | DESTONIFICADO V3 · DESTONIFIED V3 |

| ESCALA DE LA GRÁFICA 1/2 · GRAPHIC SCALE 1/2 |

90x90 cm  
35,4"x35,4"

60x120 cm  
23,6"x47,2"

60x60 cm  
23,6"x23,6"

FORMATOS DISPONIBLES AVAILABLE FORMATS	ACABADO LAPADO BRILLO GLOSSY LAPATTO FINISH 
90x90 cm · 35,4"x35,4"	<b>BROOKLYN LUX 9090   B52</b> (cream, ice)
60x120 cm · 23,6"x47,2"	<b>BROOKLYN LUX 120   B83</b>
60x60 cm · 23,6"x23,6"	<b>BROOKLYN LUX 60   B37</b>
TAMAÑO DEL LIENZO: DOS LIENZOS 100x200 cm · GRAPHIC CHART SIZE: TWO GRAPHIC CHARTS 39,4"x78,7"	



**E**

CREAM



**E**

ICE

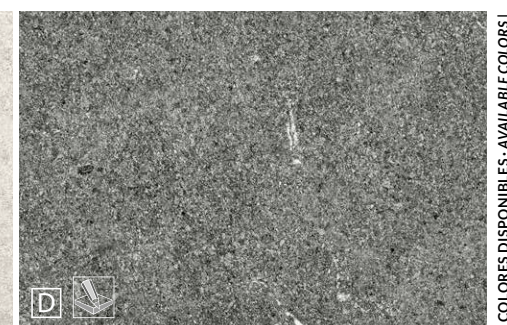

**D**

GREY

| COLORES DISPONIBLES · AVAILABLE COLORS |





wall and floor: BROOKLYN LUX 9090 ICE (90x90cm).





wall: DOMINO SOFT 120 WHITE (60x120 cm), DELHI 20 ALMOND (19,4x120 cm).  
floor: DOMINO SOFT 120 WHITE (60x120 cm).



wall: DOMINO SOFT 120 WHITE (60x120 cm), MOSAICO DOMINO SOFT I BLACK (30x30 cm).  
floor: DOMINO SOFT 120 BLACK (60x120 cm).



# DOMINO

collection

| PORCELÁNICO · PORCELAIN | RECTIFICADO · RECTIFIED | DESTONIFICADO V3 · DESTONIFIED V3 |

ESCALA DE LA GRÁFICA 1/2 - GRAPHIC SCALE 1/2 |

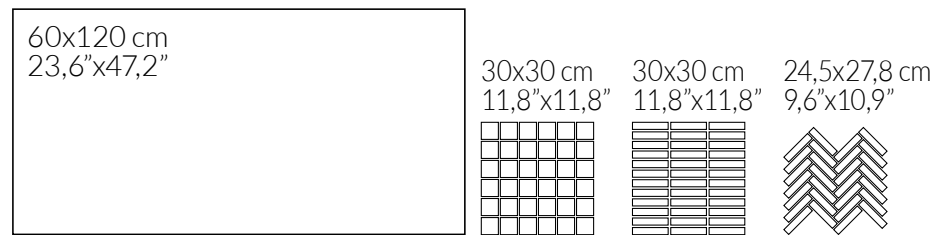

FORMATOS DISPONIBLES AVAILABLE FORMATS	ACABADO LAPADO MATE · MATT LAPATTO FINISH
60x120 cm · 23,6" x 47,2"	DOMINO SOFT 120   B83
30x30 cm · 11,8" x 11,8"	MOSAICO DOMINO SOFT T5   P60
30x30 cm · 11,8" x 11,8"	MOSAICO DOMINO SOFT I   P86 (mix, black)
24,5x27,8 cm · 9,6" x 10,9"	MOSAICO DOMINO SOFT M   P84 (white)
Nº DISEÑOS POR FORMATO · Nº DESIGNS BY FORMAT:   60x120: 8	

MOSAICO DOMINO SOFT I | 30x30 cm | P86



MIX

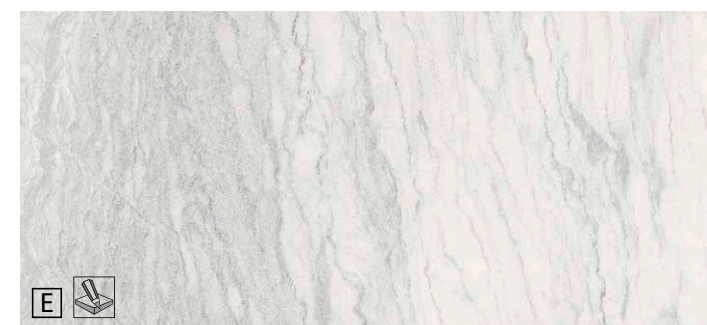

WHITE

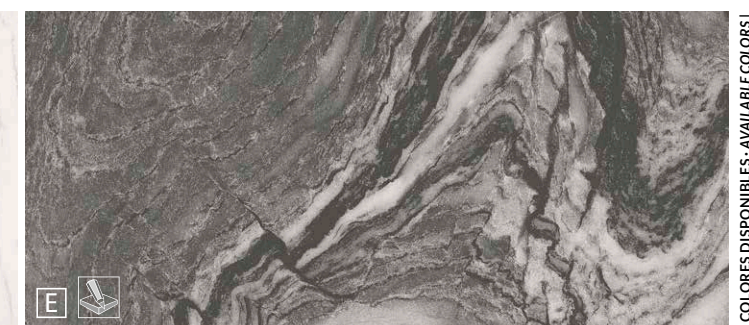

BLACK

COLORES DISPONIBLES · AVAILABLE COLORS |





wall: GROUND R90 SNOW Y GREY (30x90 cm), DECORADO GUESS R90 GREY (30x90 cm).  
 floor: GROUND LUX 60 SNOW (60x60 cm).

# GROUND collection

| PORCELÁNICO · PORCELAIN | RECTIFICADO · RECTIFIED | DESTONIFICADO V2 · DESTONIFIED V2 |

| ESCALA DE LA GRÁFICA 1/2 · GRAPHIC SCALE 1/2 |

60x60 cm  
 23,6"x23,6"

FORMATOS DISPONIBLES AVAILABLE FORMATS	ACABADO LAPADO BRILLO · GLOSSY LAPATTO FINISH 
60x60 cm - 23,6"x23,6"	GROUND LUX 60   B37
TAMAÑO DEL LIENZO: 100x200 cm · GRAPHIC CHART SIZE: 39,4"x78,7"	



floor: GROUND LUX 60 GREY (60x60 cm).

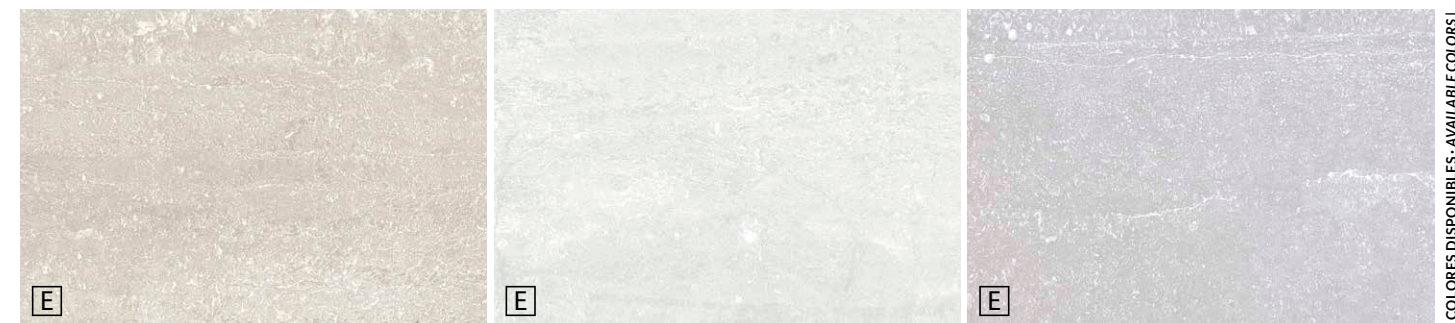

TERRA

SNOW

GREY

| COLORES DISPONIBLES · AVAILABLE COLORS |





wall: GROUND R90 SNOW Y TERRA (30x90 cm) GROUND R90 GAP TERRA (30x90 cm), DECORADO GUESS R90 TERRA (30x90 cm).  
 floor: GROUND LUX 60 TERRA (60x60 cm).



GROUND R90 GAP TERRA (30x90cm).

# GROUND collection

| PASTA BLANCA · WHITE BODY | RECTIFICADO · RECTIFIED | DESTONIFICADO V2 · DESTONIFIED V2 |

[ESCALA DE LA GRÁFICA 1/2 · GRAPHIC SCALE 1/2]

30x90 cm  
11,8"x35,4"

30x60 cm  
11,8"x23,6"

**| PIEZAS DECORATIVAS · DECORATIVE PIECES |**

GROUND R90 GAP | 30x90 cm | **B43**

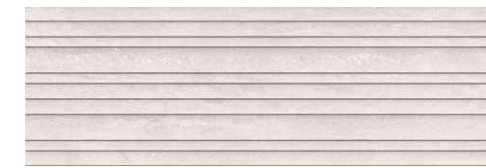

TERRA



SNOW

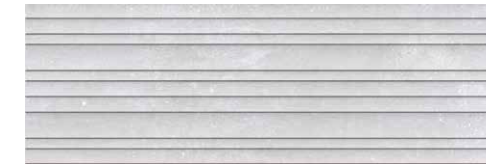

GREY





DECORADO GUESS R90 | 30x90 cm | **B42**



TERRA



GREY

FORMATOS DISPONIBLES AVAILABLE FORMATS	ACABADO BRILLO · GLOSSY FINISH  
30x90 cm · 11,8"x35,4"	GROUND R90   <b>B42</b>
	DECORADO GUESS R90   <b>B42</b>
30x60 cm · 11,8"x23,6"	GROUND R90 GAP   <b>B43</b>  
	GROUND R3060 RECT.   <b>B65</b>
DECORADO GUESS R3060 RECT.   <b>B66</b>	
TAMAÑO DEL LIENZO: 100x200 cm · GRAPHIC CHART SIZE: 39,4"x78,7"	

DECORADO GUESS R3060 RECT. | 30x60 cm | **B66**



TERRA



GREY



TERRA

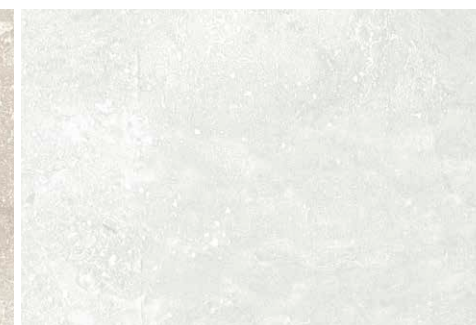

SNOW



GREY

[COLORES DISPONIBLES · AVAILABLE COLORS]





wall: PORTOPETRO R90 SAND (30x90 cm) PORTOPETRO R90 SALT SAND (30x90 cm), DECORADO LAMEO R120 ROVERE (40x120 cm).  
floor: SANTANYI 9090 SAND (90x90 cm).

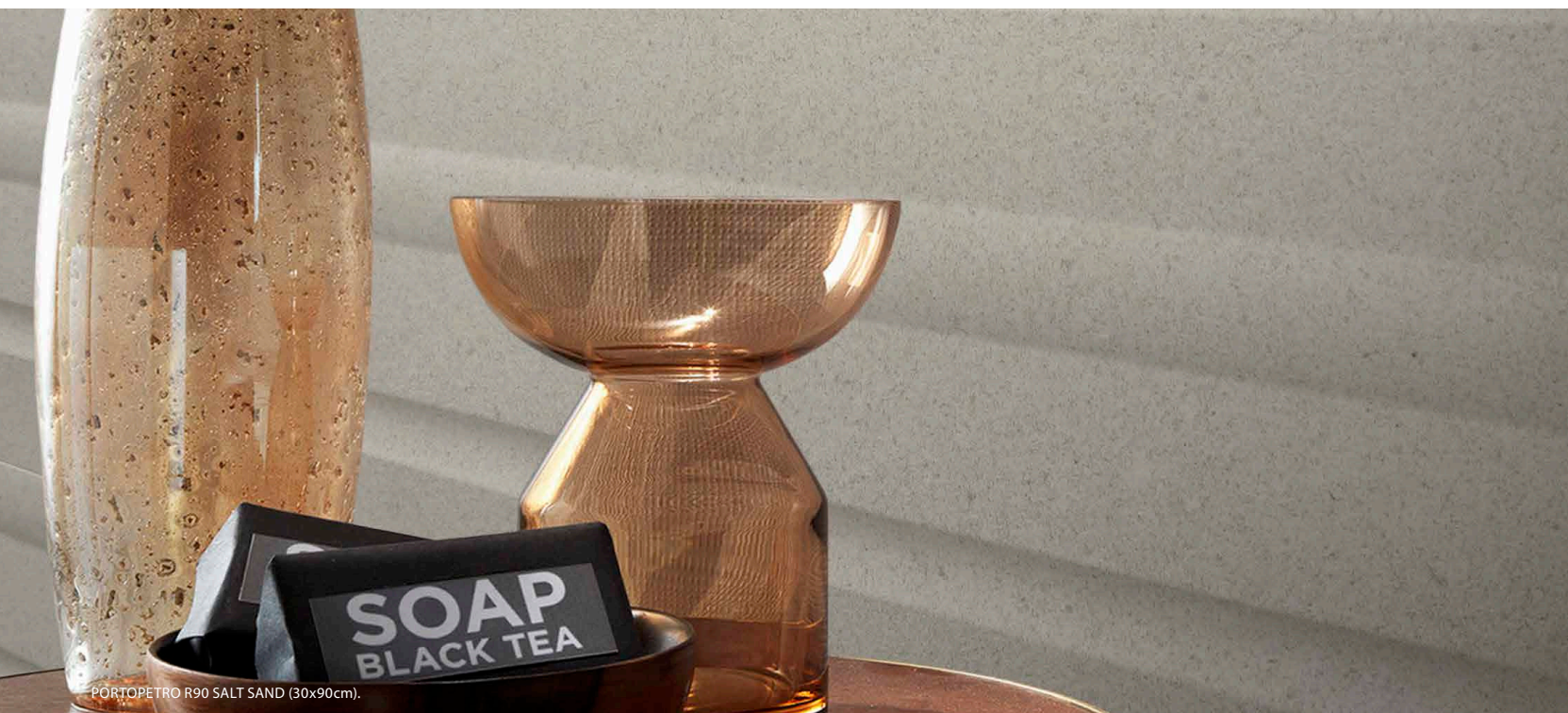

PORTOPETRO R90 SALT SAND (30x90 cm).

# PORTOPETRO collection

| PASTA BLANCA · WHITE BODY | RECTIFICADO · RECTIFIED | DESTONIFICADO V1 · DESTONIFIED V1 |

ESCALA DE LA GRÁFICA 1/2 · GRAPHIC SCALE 1/2 |

| PIEZAS DECORATIVAS · DECORATIVE PIECES |

DECORADO SUAU R90 | 30x90 cm | B44



SAND



WHITE

DECORADO SPINE R90 | 30x90 cm | B44

Tres piezas diferentes. Unidad de venta: 1 caja. · Three different pieces. Sales unit: 1 box.



NUDE

PORTOPETRO R90 SALT | 30x90 cm | B43



SAND



WHITE

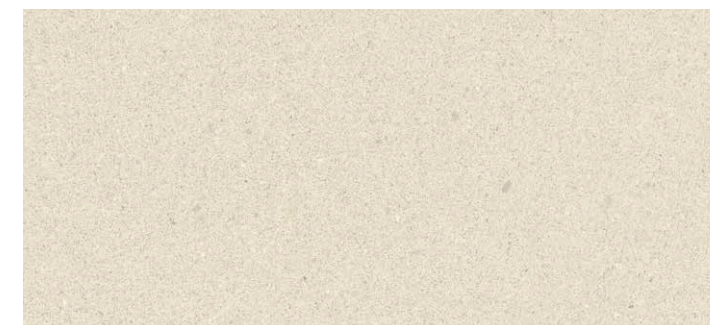

SAND

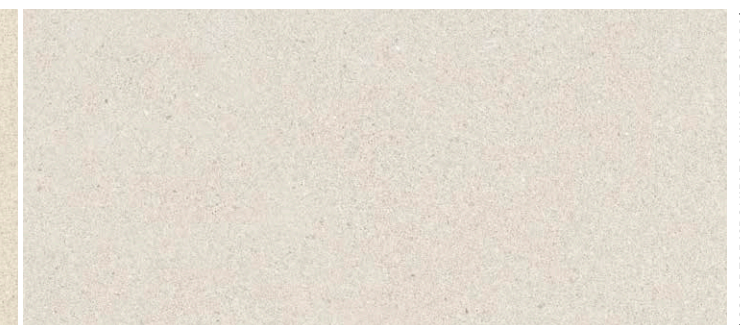

WHITE

30x90 cm  
11,8"x35,4"

FORMATOS DISPONIBLES AVAILABLE FORMATS	ACABADO MATE MATT FINISH 
	PORTOPETRO R90   B42
	DECORADO SUAU R90   B44 
	DECORADO SPINE R90   B44 
30x90 cm · 11,8"x35,4"	PORTOPETRO R90 SALT   B43 
	TAMAÑO DEL LIENZO: 101x215 cm · GRAPHIC CHART SIZE: 39,8"x84,6"

COLORES DISPONIBLES · AVAILABLE COLORS |





wall: PORTOPETRO R90 SAND (30x90 cm), DECORADO SUAU R90 SAND (30x90 cm), ESSENZA 15x15 CLAY (15x15 cm).  
floor: SANTANYI 9090 SAND (90x90 cm).



wall: DECORADO SUAU R90 WHITE (30x90 cm).



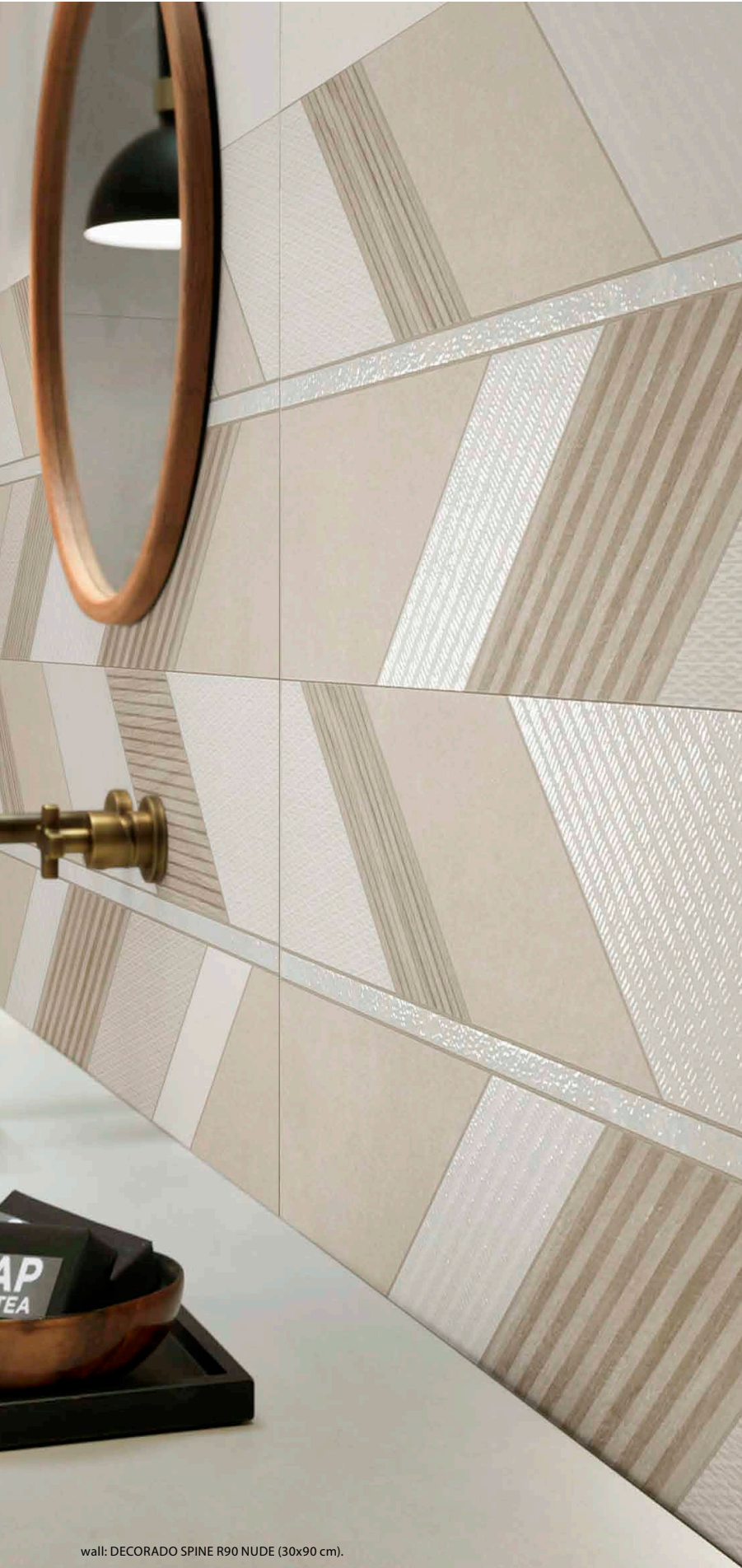

wall: DECORADO SPINE R90 NUDE (30x90 cm).



wall: PORTOPETRO R90 WHITE (30x90 cm), DECORADO SPINE R90 NUDE (30x90 cm).  
floor: NEBRASKA 20 MIEL (20x120 cm), NEBRASKA 30 MIEL (30x120 cm).





wall: PORTOPETRO R90 SALT WHITE (30x90 cm), PORTOPETRO R90 WHITE (30x90 cm).  
 floor: SANTANYI 120 WHITE (60x120 cm).

# SANTANYI collection

| PORCELÁNICO · PORCELAIN | RECTIFICADO · RECTIFIED | DESTONIFICADO V1 · DESTONIFIED V1 |

| ESCALA DE LA GRÁFICA 1/2 · GRAPHIC SCALE 1/2 |

90x90 cm  
35,4"x35,4"

60x120 cm  
23,6"x47,2"

60x60 cm  
23,6"x23,6"

FORMATOS DISPONIBLES AVAILABLE FORMATS	ACABADO NATURAL NATURAL FINISH 	ACABADO NATURAL NATURAL FINISH 	ACABADO ANTIDESLIZANTE SLIP RESISTANCE FINISH 
90x90 cm · 35,4"x35,4"	SANTANYI 9090   B50	SANTANYI C2 9090   B50 (Grey, Sand)	SANTANYI DRY 9090   B51 (Grey, Sand)
60x120 cm · 23,6"x47,2"	SANTANYI 120   B85	SANTANYI C2 120   B85 (Grey, Sand)	SANTANYI DRY 120   B86 (Grey, Sand)
60x60 cm · 23,6"x23,6"	SANTANYI 60   B35	SANTANYI C2 60   B35 (Grey, Sand)	SANTANYI DRY 60   B36 (Grey, Sand)
TAMAÑO DEL LIENZO: 101x215 cm · GRAPHIC CHART SIZE: 39,8"x84,6"			



| COLORES DISPONIBLES · AVAILABLE COLORS |





floor: SANTANYI 9090 GREY (90x90 cm), SANTANYI DRY 9090 GREY (90x90 cm).



floor: SANTANYI DRY 120 SAND (60x120 cm), PELDAÑO EXT SANTANYI DRY 120 SAND (33x120 cm).

NEW  
PELDAÑO - STEPS  
33x120cm / 13"x48"  
COMPACTO  
NATURAL  
ANTISLIP  
EXTRUSIONADO



wall: DECORADO SUAU R90 SAND (30x90 cm), PORTOPETRO R90 SALT SAND (30x90 cm), DECORADO MIRROR R120 GOLD (40x120 cm).  
floor: SANTANYI 120 SAND (60x120 cm).





floor: SEASTONE 60 GREY (60x60 cm), SEASTONE DRY 60 GREY (60x60 cm).





# SEASTONE<sub>collection</sub>

| PORCELÁNICO · PORCELAIN | RECTIFICADO · RECTIFIED | DESTONIFICADO V3 · DESTONIFIED V3 |

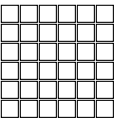
| ESCALA DE LA GRÁFICA 1/2 · GRAPHIC SCALE 1/2 |

60x120 cm 23,6"x47,2"	60x60 cm 23,6"x23,6"	30x30 cm 11,8"x11,8" 
--------------------------	-------------------------	--

FORMATOS DISPONIBLES AVAILABLE FORMATS	ACABADO NATURAL · NATURAL FINISH 	ACABADO ANTIDESLIZANTE · SLIP RESISTANCE FINISH 
60x120 cm · 23,6"x47,2"	SEASTONE 120   B85	SEASTONE DRY 120   B86 (taupe, grey)
60x60 cm · 23,6"x23,6"	SEASTONE 60   B35	SEASTONE DRY 60   B36 (taupe, grey)
30x30 cm · 11,8"x11,8"	MOSAICO SEASTONE T5   P70 	---
Nº DISEÑOS POR FORMATO · Nº DESIGNS BY FORMAT:   60x120: 4   60x60: 8		



TAUPE

WHITE

GREY

GRAPHITE

| COLORES DISPONIBLES · AVAILABLE COLORS |





wall: SEASTONE 120 WHITE Y GREY (60x120 cm).  
floor: SEASTONE 120 GREY (60x120 cm).

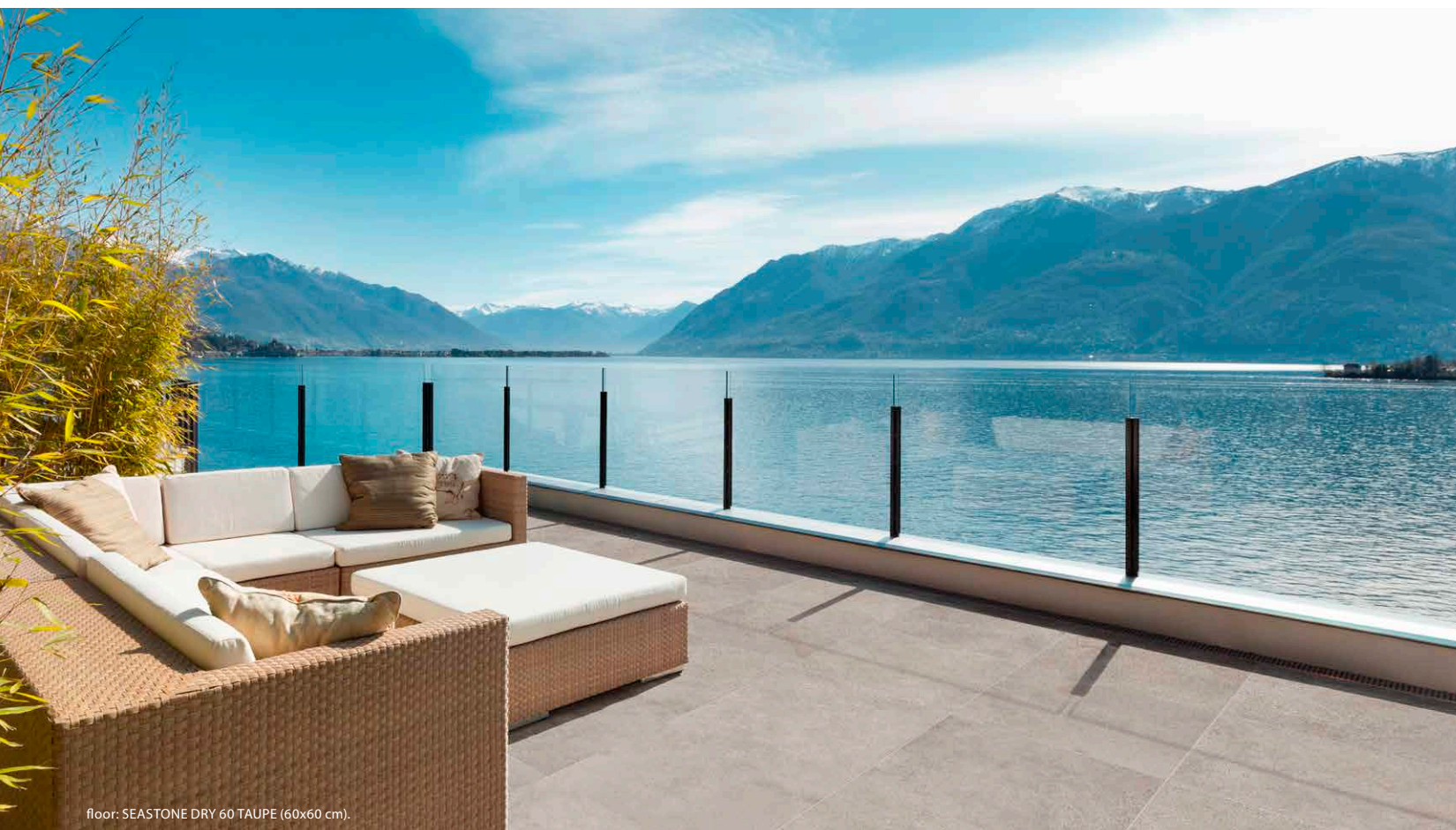

floor: SEASTONE DRY 60 TAUPE (60x60 cm).



wall: SEASTONE 120 WHITE Y GRAPHITE (60x120 cm).  
floor: SEASTONE 120 GREY (60x120 cm).





floor: SHELLSTONE 9090 GREY (90x90 cm)

# SHELLSTONE collection

| PORCELÁNICO · PORCELAIN | RECTIFICADO · RECTIFIED | DESTONIFICADO V2 · DESTONIFIED V2 |

| ESCALA DE LA GRÁFICA 1/2 - GRAPHIC SCALE 1/2 |

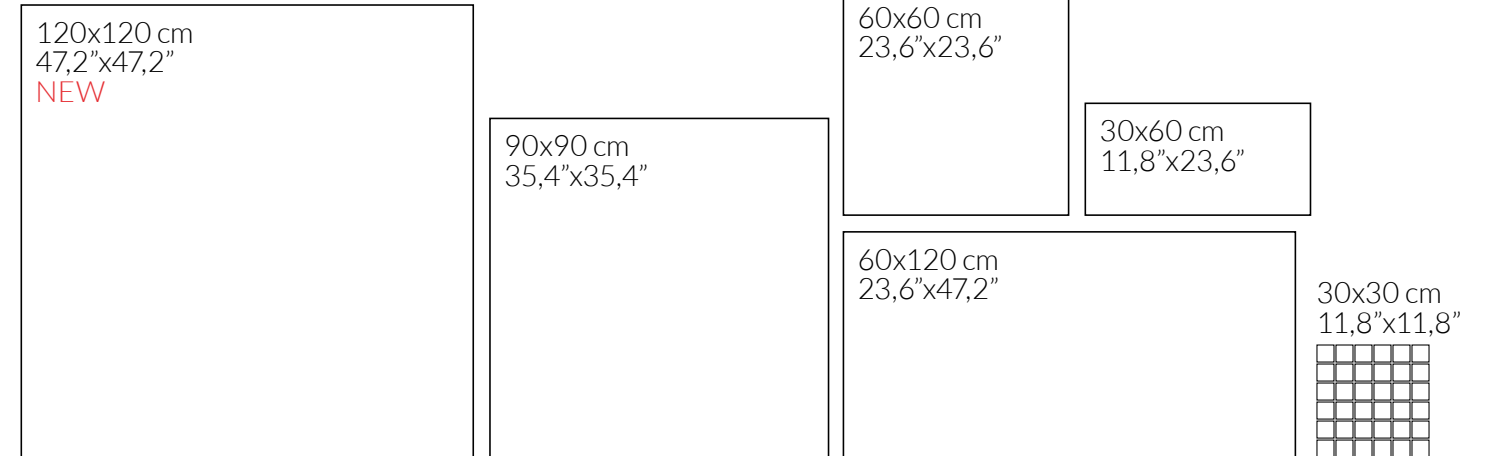

FORMATOS DISPONIBLES AVAILABLE FORMATS	ACABADO NATURAL - NATURAL FINISH 	ACABADO ANTIDESLIZANTE - SLIP RESISTANCE FINISH 
120x120 cm · 47,2"x47,2"	SHELLSTONE 120x120   B04	SHELLSTONE DRY 120x120   B11 (grey, cream)
90x90 cm · 35,4"x35,4"	SHELLSTONE 9090   B50	SHELLSTONE DRY 9090   B51
60x120 cm · 23,6"x47,2"	SHELLSTONE 120   B85	SHELLSTONE DRY 120   B86
60x60 cm · 23,6"x23,6"	SHELLSTONE 60   B35	SHELLSTONE DRY 60   B36
30x60 cm · 11,8"x23,6"	SHELLSTONE 3060   B35	SHELLSTONE DRY 3060   B36
30x30 cm · 11,8"x11,8"	MOSAICO SHELLSTONE T5   P70	---

Nº DISEÑOS POR FORMATO · Nº DESIGNS BY FORMAT: | 120x120: 7 | 90x90: 11 | 60x120: 12 | 60x60: 20 | 30x60: 40 |



| COLORES DISPONIBLES · AVAILABLE COLORS |





wall: SHELLSTONE R90 LOT CREAM (30x90 cm), SHELLSTONE 120 WHITE Y CREAM (60x120 cm).  
floor: SHELLSTONE 120 CREAM (60x120 cm).





wall: SHELLSTONE R90 CREAM (30x90 cm) SHELLSTONE R90 LOT CREAM (30x90 cm).



SHELLSTONE R90 LOT WHITE (30x90cm).

# SHELLSTONE collection

| PASTA BLANCA · WHITE BODY | RECTIFICADO · RECTIFIED | DESTONIFICADO V2 · DESTONIFIED V2 |

| ESCALA DE LA GRÁFICA 1/2 · GRAPHIC SCALE 1/2 |

**| PIEZAS DECORATIVAS · DECORATIVE PIECES |**

**DECORADO COZY R90 | 30x90 cm | B44**  
 Cinco piezas diferentes. Unidad de venta: 1 caja. - Five different pieces. Sales unit: 1 box.



**DECORADO CANDY R90 | 30x90 cm | B44**  
 Cinco piezas diferentes. Unidad de venta: 1 caja. - Five different pieces. Sales unit: 1 box.



**SHELLSTONE R90 LOT | 30x90 cm | B43**



GREIGE



CREAM



WHITE



GREY

30x90 cm  
 11,8"x35,4"

FORMATOS DISPONIBLES AVAILABLE FORMATS	ACABADO MATE · MATT FINISH
30x90 cm · 11,8"x35,4"	SHELLSTONE R90   B42
	DECORADO COZY R90   B44
	DECORADO CANDY R90   B44
	SHELLSTONE R90 LOT   B43
Nº DISEÑOS POR FORMATO · Nº DESIGNS BY FORMAT:   30x90: 7	



GREIGE

CREAM

WHITE

GREY

| COLORES DISPONIBLES · AVAILABLE COLORS |





floor: SHELLSTONE DRY 120 CREAM (60x120 cm)



wall: SHELLSTONE R90 GREIGE (30x90 cm), SHELLSTONE R90 LOT GREIGE (30x90 cm).  
floor: SHELLSTONE 60 GREIGE (60x60 cm).



wall: DECORADO COZY R90 (30x90 cm), SHELLSTONE R90 WHITE Y GREY (30x90 cm).  
floor: SHELLSTONE 60 GREY (60x60 cm).





wall: STONEAGE 120 IVORY (60x120 cm).  
 floor: STONEAGE 120 SAND (60x120 cm), STONEAGE DRY 120 SAND (60x120 cm).



wall: STONEAGE 120 IVORY (60x120 cm).  
 floor: STONEAGE 120 GRAPHITE (60x120 cm).



# STONEAGE collection

| PORCELÁNICO · PORCELAIN | RECTIFICADO · RECTIFIED | DESTONIFICADO V2 · DESTONIFIED V2 |

ESCALA DE LA GRÁFICA 1/2 · GRAPHIC SCALE 1/2 |

60x120 cm 23,6"x47,2"	60x60 cm 23,6"x23,6"	30x60 cm 11,8"x23,6"
--------------------------	-------------------------	-------------------------

FORMATOS DISPONIBLES AVAILABLE FORMATS	ACABADO NATURAL NATURAL FINISH	ACABADO ANTIDESLIZANTE SLIP RESISTANCE FINISH	ACABADO LAPADO BRILLO GLOSSY LAPATTO FINISH
60x120 cm · 23,6"x47,2"	STONEAGE 120   B85	STONEAGE DRY 120   B86	STONEAGE LUX 120   B83
60x60 cm · 23,6"x23,6"	STONEAGE 60   B35	STONEAGE DRY 60   B36	STONEAGE LUX 60   B37
30x60 cm · 11,8"x23,6"	STONEAGE 3060   B35	STONEAGE DRY 3060   B36	STONEAGE LUX 3060   B37
Nº DISEÑOS POR FORMATO · Nº DESIGNS BY FORMAT:   60x120: 8   60x60: 16   30x60: 32			

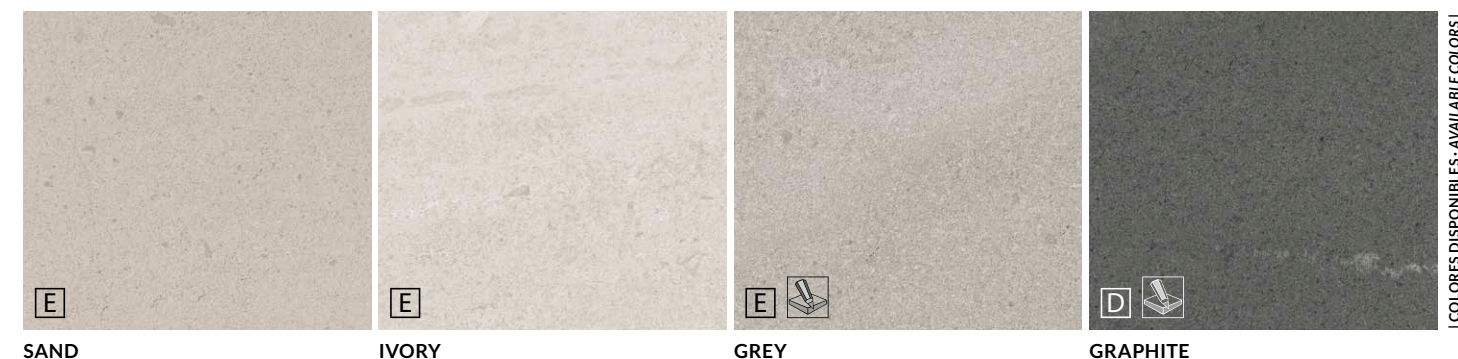

COLORES DISPONIBLES · AVAILABLE COLORS |





wall: STONEAGE LUX 120 IVORY (60x120 cm).  
floor: STONEAGE LUX 120 GRAPHITE (60x120 cm), STONEAGE DRY 120 GRAPHITE (60x120 cm).



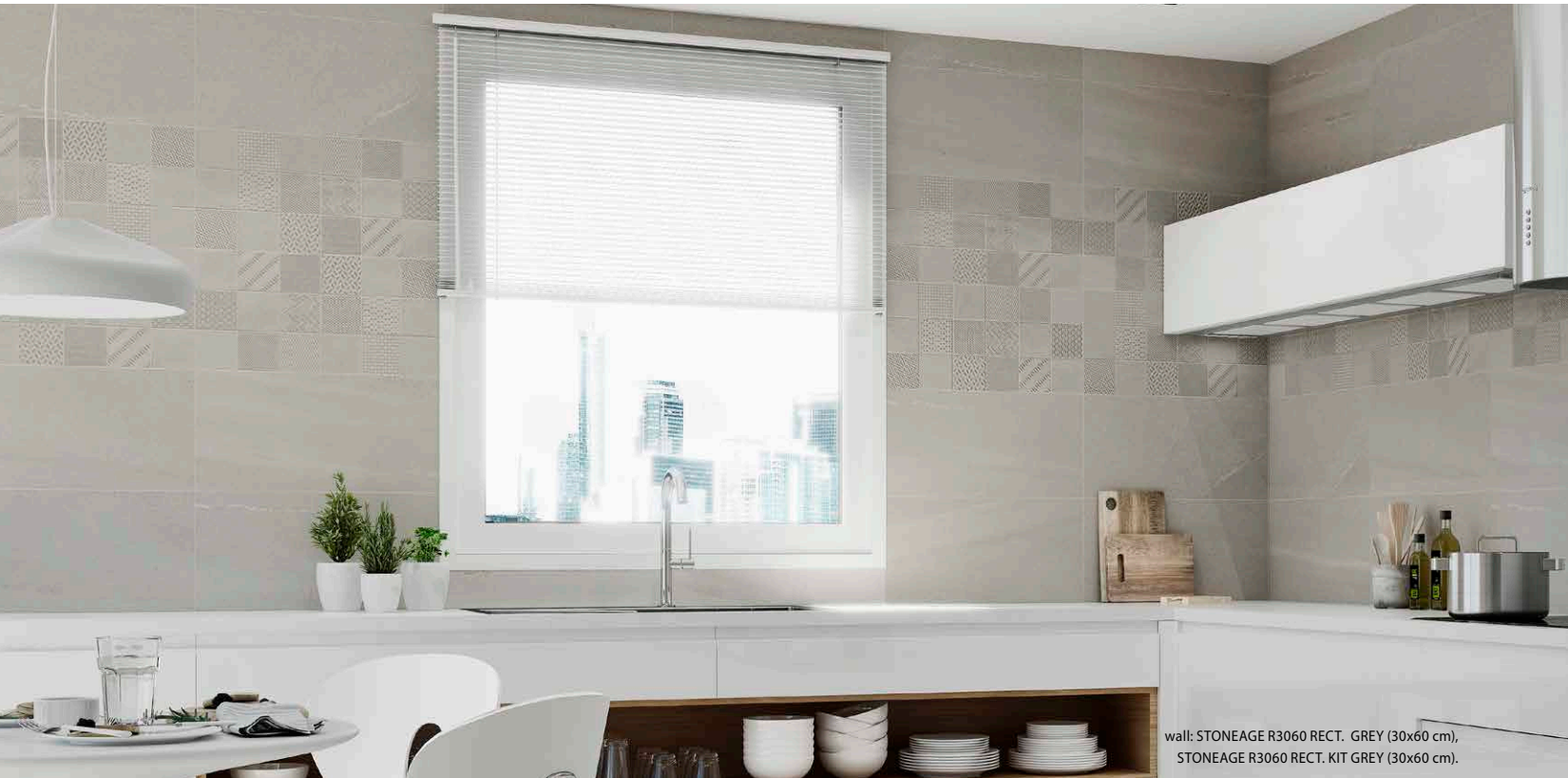

wall: STONEAGE R3060 RECT. GREY (30x60 cm),  
STONEAGE R3060 RECT. KIT GREY (30x60 cm).



wall: STONEAGE R3060 RECT. SAND (30x60 cm), STONEAGE R3060 RECT. KIT SAND (30x60 cm).  
floor: STONEAGE 60 SAND (60x60 cm).

# STONEAGE collection

| PASTA BLANCA · WHITE BODY | RECTIFICADO · RECTIFIED | DESTONIFICADO V2 · DESTONIFIED V2 |

ESCALA DE LA GRÁFICA 1/2 · GRAPHIC SCALE 1/2 |

## | PIEZAS DECORATIVAS · DECORATIVE PIECES |

STONEAGE R3060 RECT. KIT | 30x60 cm | B67



SAND



IVORY



GREY



GRAPHITE

30x60 cm  
11,8"x23,6"

FORMATOS DISPONIBLES  
AVAILABLE FORMATS

ACABADO MATE · MATT FINISH



30x60 cm · 11,8"x23,6"

STONEAGE R3060 RECT. | B65

STONEAGE R3060 RECT. KIT | B67



Nº DISEÑOS POR FORMATO · Nº DESIGNS BY FORMAT: | 30x60: 16 |



SAND



IVORY



GREY

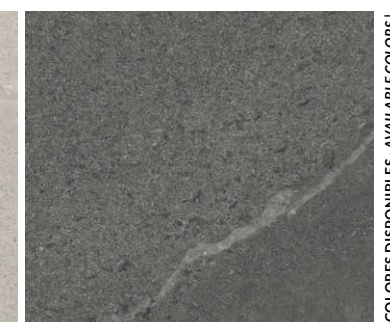

GRAPHITE

COLORES DISPONIBLES · AVAILABLE COLORS |





floor: TOSCANA 9090 BEIGE (90x90 cm).



# TOSCANA

collection  
| PORCELÁNICO · PORCELAIN | RECTIFICADO · RECTIFIED | DESTONIFICADO V2 · DESTONIFIED V2 |

ESCALA DE LA GRÁFICA 1:2 · GRAPHIC SCALE 1/2



wall: TOSCANA R3060 RECT. SIL MIX (30x60 cm).  
floor: TOSCANA 9090 GRIS (90x90 cm).

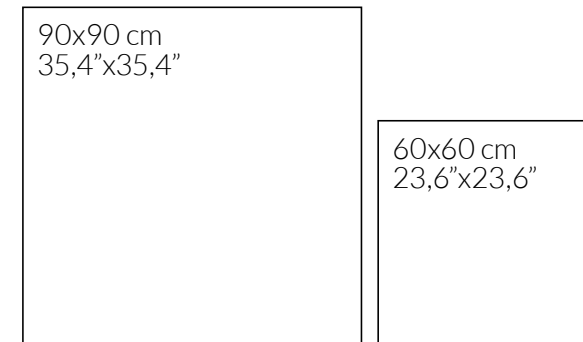

FORMATOS DISPONIBLES AVAILABLE FORMATS	ACABADO NATURAL · NATURAL FINISH 	ACABADO ANTIDESLIZANTE · SLIP RESISTANCE FINISH 
90x90 cm · 35,4"x35,4"	TOSCANA 9090   B50	TOSCANA DRY 9090   B51 (beige, gris)
60x60 cm · 23,6"x23,6"	TOSCANA 60   B35	---

TAMAÑO DEL LIENZO: DOS LIENZOS 100x200 cm · GRAPHIC CHART SIZE: TWO GRAPHIC CHARTS 39,4"x78,7"



BEIGE

BLANCO

GRIS

GRAFITO

COLORES DISPONIBLES · AVAILABLE COLOURS





wall: TOSCANA R3060 RECT. BLANCO (30x60 cm).  
floor: TOSCANA 60 BLANCO (60x60 cm).



wall: TOSCANA R90 BLANCO Y GRIS (30x90 cm), TOSCANA R90 PLANE BLANCO (30x90 cm).  
floor: TOSCANA 60 GRIS (60x60 cm).



# TOSCANA

collection

| PASTA BLANCA · WHITE BODY | RECTIFICADO · RECTIFIED | DESTONIFICADO V2 · DESTONIFIED V2 |

| ESCALA DE LA GRÁFICA 1/2 · GRAPHIC SCALE 1/2 |

| PIEZAS DECORATIVAS · DECORATIVE PIECES |

TOSCANA R3060 RECT. SIL | 30x60 cm | **B67**

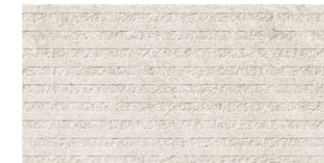

BEIGE



BLANCO

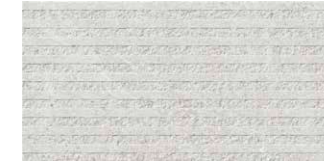

GRIS



MIX

TOSCANA R90 PLANE | 30x90 cm | **B43**



BEIGE



BLANCO



GRIS

30x90 cm  
11,8"x35,4"

30x60 cm  
11,8"x23,6"

FORMATOS DISPONIBLES AVAILABLE FORMATS	ACABADO MATE · MATT FINISH
30x90 cm · 11,8"x35,4"	<b>TOSCANA R90   B42</b>  <b>TOSCANA R90 PLANE   B43</b> 
30x60 cm · 11,8"x23,6"	<b>TOSCANA R3060 RECT.   B65</b>  <b>TOSCANA R3060 RECT. SIL   B67</b> 
TAMAÑO DEL LIENZO: 2 LIENZOS 100x200 cm · GRAPHIC CHART SIZE: 2 GRAPHIC CHARTS 39,4"x78,7"	



BEIGE

BLANCO

GRIS

| COLORES DISPONIBLES · AVAILABLE COLORS |





**METAL | METAL**

COSMOS	156 - 157
ELEKTRA	158 - 161
FAME	162 - 165
HARLEY	166 - 167
MIRROR - <b>NEW</b>	168 - 169
ORION	170 - 173
SAHARA - <b>NEW</b>	174 - 177
SMART	178 - 179
SYNTHESIS	180 - 183

**AZTECA**





wall: COSMOS LUX 3060 ÓXIDO (30x60 cm), MOSAICO COSMOS LUX 30 ÓXIDO (30x30 cm).  
floor: COSMOS LUX 60 BEIGE (60x60 cm).



wall: COSMOS LUX 3060 BLANCO (30x60 cm).  
floor: COSMOS LUX 60 NEGRO (60x60 cm).

# COSMOS<sub>collection</sub>

| PORCELÁNICO · PORCELAIN | RECTIFICADO · RECTIFIED | DESTONIFICADO V2 · DESTONIFIED V2 |

[ESCALA DE LA GRÁFICA 1:2 · GRAPHIC SCALE 1/2]

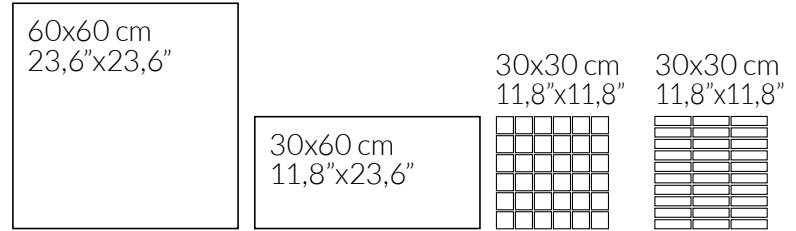

FORMATOS DISPONIBLES AVAILABLE FORMATS	ACABADO LAPADO BRILLO GLOSSY LAPATTO FINISH
60x60 cm · 23,6" x 23,6"	COSMOS LUX 60   B37
30x60 cm · 11,8" x 23,6"	COSMOS LUX 3060   B37
30x30 cm · 11,8" x 11,8"	MOSAICO COSMOS LUX T5   P60
30x30 cm · 11,8" x 11,8"	MOSAICO COSMOS LUX 30   P91  (óxido, negro)



ÓXIDO



BEIGE

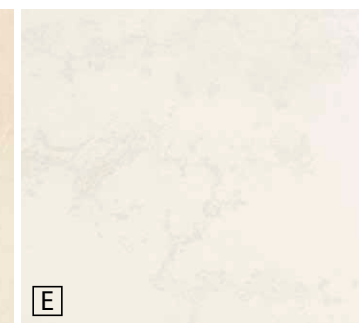

BLANCO



NEGRO

[COLORES DISPONIBLES · AVAILABLE COLORS]





wall: ELEKTRA LUX 120 SUPERWHITE (60x120 cm).  
floor: ELEKTRA LUX 120 GRAPHITE (60x120 cm).

# ELEKTRA<sub>collection</sub>



| PORCELÁNICO · PORCELAIN | RECTIFICADO · RECTIFIED | DESTONIFICADO V1 · DESTONIFIED V1 |

60x120 cm  
23,6"x47,2"

60x60 cm  
23,6"x23,6"

30x60 cm  
11,8"x23,6"

30x30 cm  
11,8"x11,8"

FORMATOS DISPONIBLES AVAILABLE FORMATS	ACABADO LAPADO METALIZADO · METALLIC LAPATTO FINISH  >0,42	ACABADO PVD · PVD FINISH 
60x120 cm · 23,6"x47,2"	ELEKTRA LUX 120   B84	DECORADO ELEKTRA 120   P83 (gold, silver)
60x60 cm · 23,6"x23,6"	ELEKTRA LUX 60   B46	DECORADO ELEKTRA 60   P79 (gold, silver)
30x60 cm · 11,8"x23,6"	ELEKTRA LUX 3060   B46	DECORADO ELEKTRA 3060   P67 (gold, silver)
30x30 cm · 11,8"x11,8"	MOSAICO ELEKTRA LUX T5   P71  (superwhite, graphite, black, mix)	---

| PIEZAS DECORATIVAS · DECORATIVE PIECES |

DECORADO ELEKTRA 120 | 60x120 cm | P83

DECORADO ELEKTRA 60 | 60x60 cm | P79

DECORADO ELEKTRA 3060 | 30x60 cm | P67



GOLD



GOLD

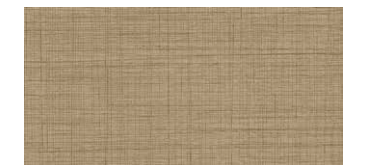

GOLD

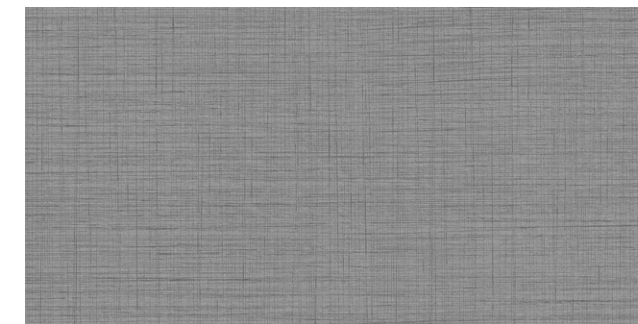

SILVER

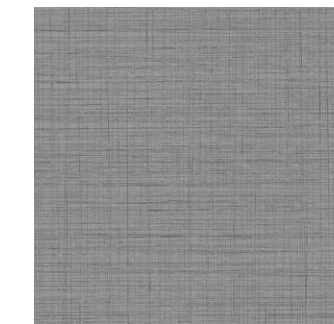

SILVER

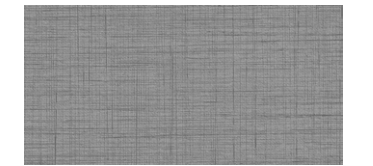

SILVER

Colocación y mantenimiento de baldosas cerámicas con recubrimiento PVD. Página 328.  
Placement and maintenance of ceramic tiles with PVD coating. Page 329.

MOSAICO ELEKTRA LUX T5 | 30x30 cm | P71

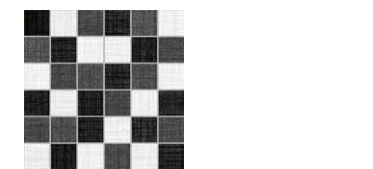

MIX

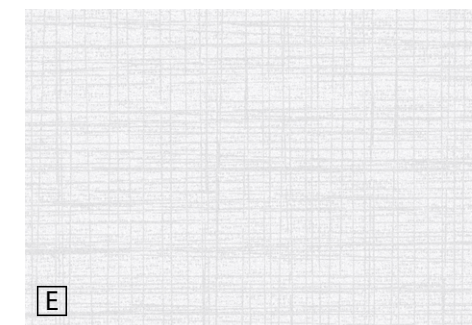

SUPERWHITE

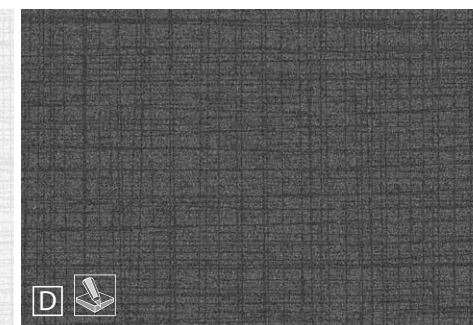

GRAPHITE

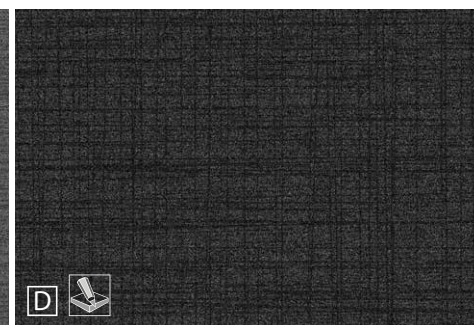

BLACK

COLORES DISPONIBLES · AVAILABLE COLORS



furniture: ELEKTRA LUX 120 SUPERWHITE (60x120 cm).  
floor: ELEKTRA LUX 120 BLACK (60x120 cm).





wall: DECORADO ELEKTRA 120 GOLD (60x120cm), INVISIBLE NAT 120 WHITE (60x120cm).  
floor: INVISIBLE NAT 120 WHITE (60x120cm).





wall: FAME LUX 120 WHITE Y BLACK (60x120cm).  
 floor: FAME LUX 120 WHITE (60x120cm), MOSAICO FAME LUX HEX BLACK (29,3x25,4cm).

# FAME collection

| PORCELÁNICO · PORCELAIN | RECTIFICADO · RECTIFIED | DESTONIFICADO V1 · DESTONIFIED V1 |

60x120 cm 23,6"x47,2"	60x60 cm 23,6"x23,6"	30x60 cm 11,8"x23,6"	29,3x25,4 cm 11,5"x10"
--------------------------	-------------------------	-------------------------	---------------------------

FORMATOS DISPONIBLES AVAILABLE FORMATS	ACABADO LAPADO METALIZADO · METALLIC LAPATTO FINISH
60x120 cm · 23,6"x47,2"	FAME LUX 120   B84
60x60 cm · 23,6"x23,6"	FAME LUX 60   B46
30x60 cm · 11,8"x23,6"	FAME LUX 3060   B46
29,3x25,4 cm · 11,5"x10"	MOSAICO FAME LUX HEX   P15

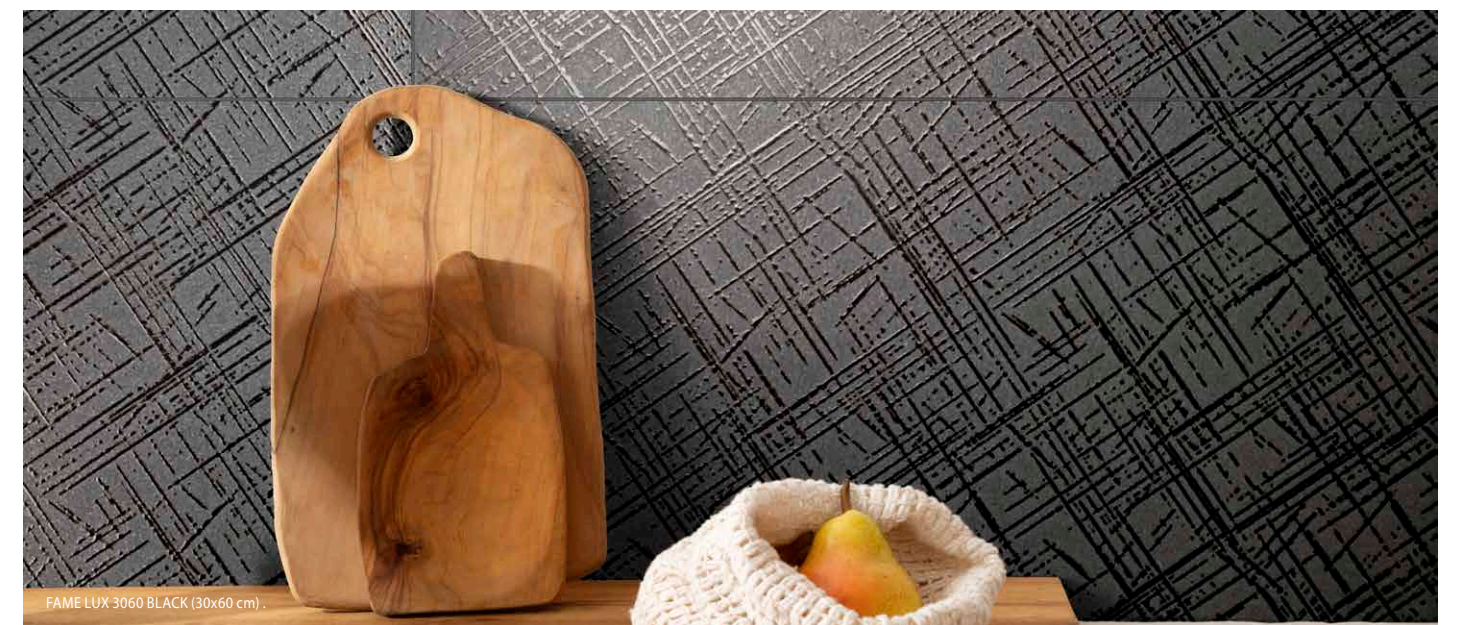

FAME LUX 3060 BLACK (30x60 cm)



WHITE



BLACK

COLORES DISPONIBLES · AVAILABLE COLORS





wall: FAME LUX 120 WHITE (60x120cm), MOSAICO FAME LUX HEX WHITE (29,3x25,4cm).  
 floor: FAME LUX 120 WHITE (60x120cm).



wall: FAME LUX 120 WHITE (60x120cm), MOSAICO FAME LUX HEX WHITE Y BLACK (29,3x25,4cm).  
 floor: FAME LUX 120 WHITE (60x120cm), MOSAICO FAME LUX HEX BLACK (29,3x25,4cm).





wall: MOSAICO HARLEY LUX T5 SUPERWHITE (30x30 cm), HARLEY LUX 3060 SUPERWHITE, GRAPHITE Y BLACK (30x60 cm).  
floor: HARLEY LUX 60 SUPERWHITE (60x60 cm).

# HARLEY collection

| PORCELÁNICO · PORCELAIN | RECTIFICADO · RECTIFIED | DESTONIFICADO V1 · DESTONIFIED V1 |

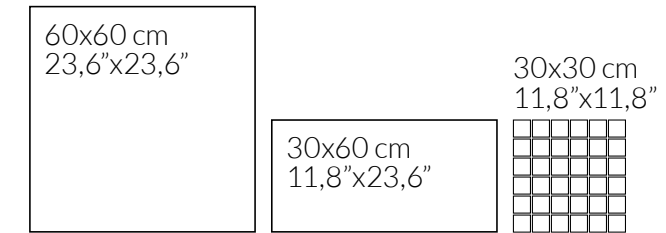

<p>FORMATOS DISPONIBLES AVAILABLE FORMATS</p>	<p>ACABADO LAPADO METALIZADO METALLIC LAPATTO FINISH</p>
<p>60x60 cm · 23,6" x 23,6"</p>	<p>HARLEY LUX 60   B46</p>
<p>30x60 cm · 11,8" x 23,6"</p>	<p>HARLEY LUX 3060   B46</p>
<p>30x30 cm · 11,8" x 11,8"</p>	<p>MOSAICO HARLEY LUX T5   P71  (superwhite, graphite, black, mix)</p>

| PIEZAS DECORATIVAS · DECORATIVE PIECES |

MOSAICO HARLEY LUX T5 | 30x30 cm | P71

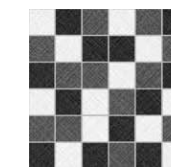

MIX

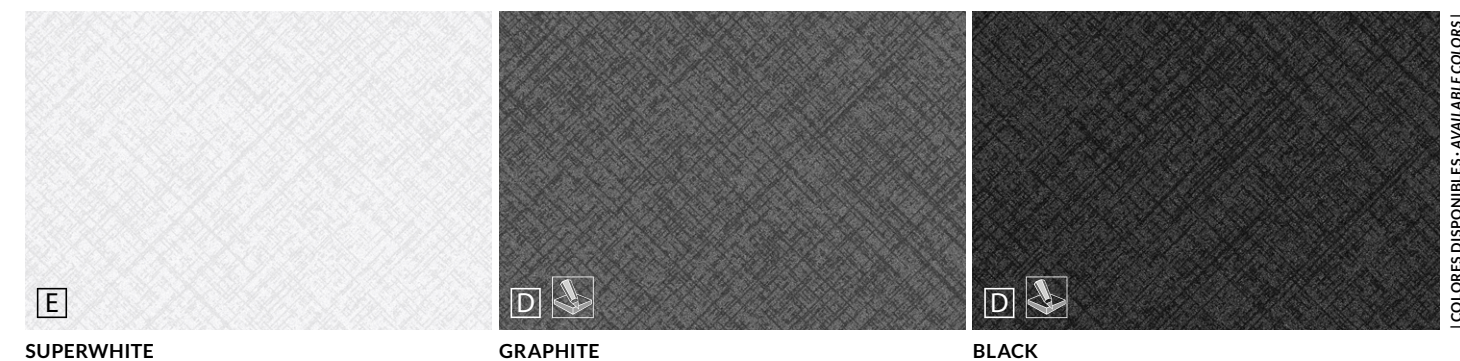

E

SUPERWHITE

D

GRAPHITE

D

BLACK

COLORES DISPONIBLES · AVAILABLE COLORS



wall: MOSAICO HARLEY LUX T5 MIX Y BLACK (30x30 cm), HARLEY LUX 3060 SUPERWHITE Y GRAPHITE (30x60 cm).  
floor: HARLEY LUX 60 GRAPHITE (60x60 cm).





wall: DECORADO MIRROR R120 GOLD (40x120 cm). LACIO MOSAIC BRICK ÁGATA IVORY (25x25 cm).  
floor: LACIO SOFT 120 IVORY (60x120 cm).

# MIRROR<sub>collection</sub>

| PASTA BLANCA · WHITE BODY | RECTIFICADO · RECTIFIED | DESTONIFICADO V2 · DESTONIFIED V2 |

| PIEZAS · PIECES |

DECORADO MIRROR R120 | 40x120 cm | P66



40x120 cm  
15,7"x47,2"

GOLD



SILVER

FORMATOS DISPONIBLES AVAILABLE FORMATS	ACABADO PVD · PVD FINISH
40x120 cm · 15,7"x47,2"	DECORADO MIRROR R120   P66
Nº DISEÑOS POR FORMATO · Nº DESIGNS BY FORMAT:   40x120: 7	



wall: DECORADO MIRROR R120 SILVER (40x120 cm).





wall: ORION SCINTILLANTE 120 TITANIUM (60x120 cm).  
floor: ORION SCINTILLANTE 60 BLUE (60x60 cm).





# ORION collection

| PORCELÁNICO · PORCELAIN | RECTIFICADO · RECTIFIED | DESTONIFICADO V3 · DESTONIFIED V3 |

| ESCALA DE LA GRÁFICA 1/2 · GRAPHIC SCALE 1/2 |

60x120 cm 23,6"x47,2"	60x60 cm 23,6"x23,6"
--------------------------	-------------------------

FORMATOS DISPONIBLES AVAILABLE FORMATS	ACABADO NATURAL METALIZADO METALLIC NATURAL FINISH 	ACABADO LAPADO METALIZADO METALLIC LAPATTO FINISH 
60x120 cm · 23,6"x47,2"	ORION SCINTILLANTE 120   B70	ORION LUX 120   B84
60x60 cm · 23,6"x23,6"	ORION SCINTILLANTE 60   B38	ORION LUX 60   B46
Nº DISEÑOS POR FORMATO · Nº DESIGNS BY FORMAT:   60x120: 8   60x60: 10		

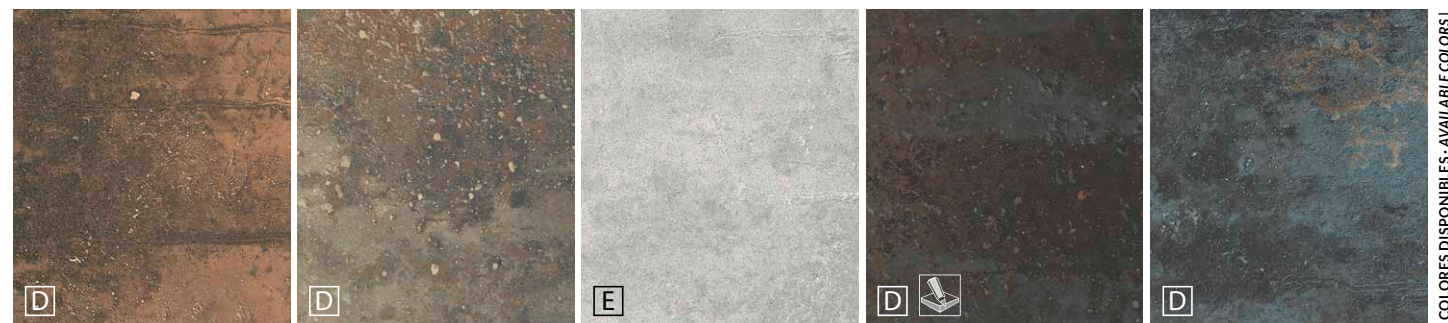

COPPER GREIGE PEARL TITANIUM BLUE

| COLORES DISPONIBLES · AVAILABLE COLORS |





wall: ORION LUX 120 PEARL (60x120 cm).  
floor: ORION LUX 120 COPPER (60x120 cm).

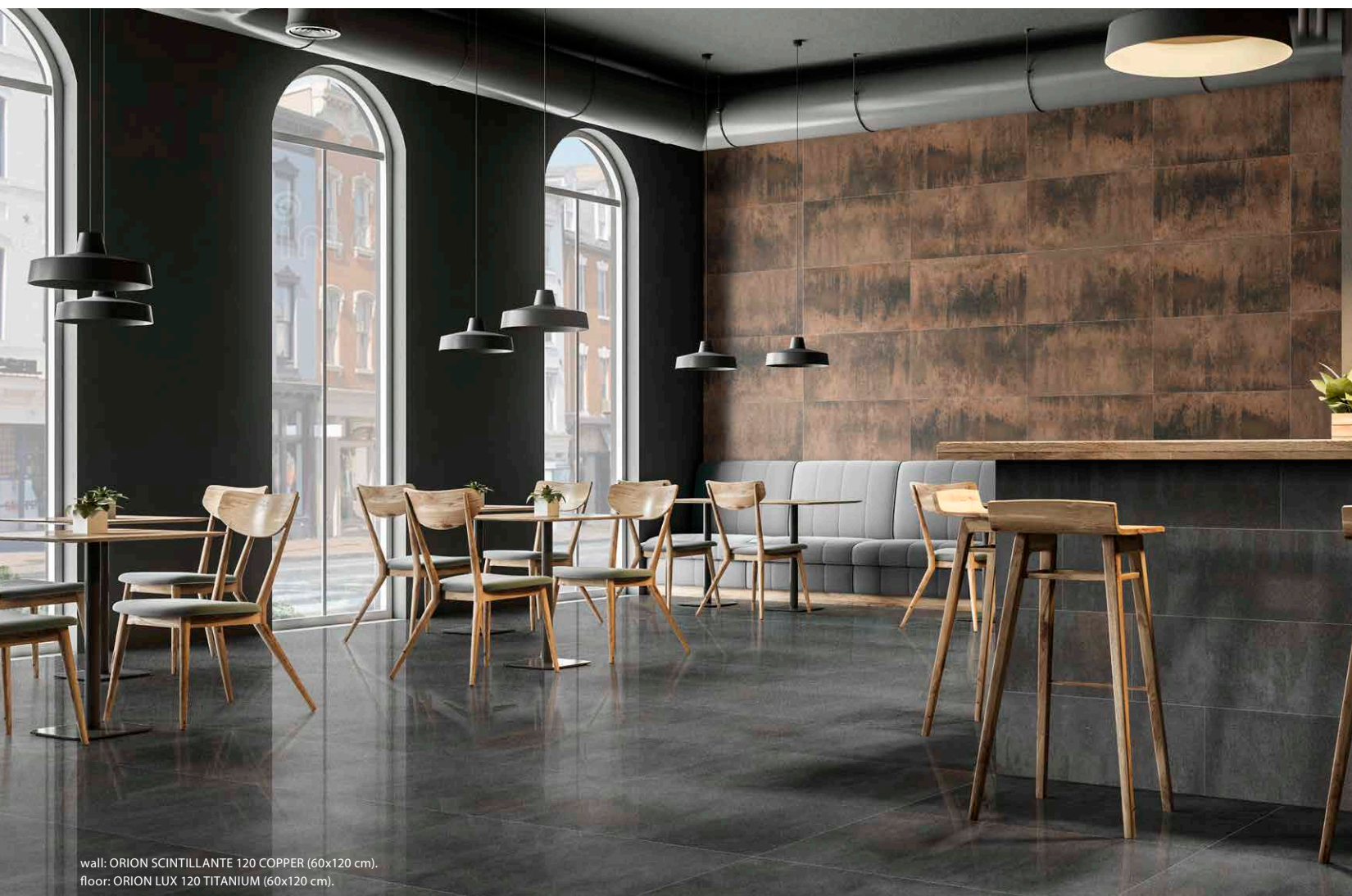

wall: ORION SCINTILLANTE 120 COPPER (60x120 cm).  
floor: ORION LUX 120 TITANIUM (60x120 cm).



wall: ORION SCINTILLANTE 120 GREIGE (60x120 cm).  
floor: ORION LUX 120 PEARL (60x120 cm).





table: SAHARA SCINTILLANTE 120 PEARL (60x120) | floor: SAHARA SCINTILLANTE 60 DARK GREY (60x60 cm)



wall: SAHARA SCINTILLANTE 120 DARK GREY (60x120 cm)



# SAHARA<sub>collection</sub>

| PORCELÁNICO · PORCELAIN | RECTIFICADO · RECTIFIED | DESTONIFICADO V2 · DESTONIFIED V2 |

| ESCALA DE LA GRÁFICA 1/2 · GRAPHIC SCALE 1/2 |

60x120 cm  
23,6"x47,2"

60x60 cm  
23,6"x23,6"

30x60 cm  
11,8"x23,6"

29,3x25,4 cm  
11,5"x10"

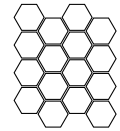

FORMATOS DISPONIBLES AVAILABLE FORMATS	ACABADO NATURAL METALIZADO · METALLIC NATURAL FINISH 
60x120 cm · 23,6"x47,2"	SAHARA SCINTILLANTE 120   B70
60x60 cm · 23,6"x23,6"	DECORADO SAHARA 120   P83  (gold, silver)
60x60 cm · 23,6"x23,6"	SAHARA SCINTILLANTE 60   B38
30x60 cm · 11,8"x23,6"	SAHARA SCINTILLANTE 3060   B38
29,3x25,4 cm · 11,5"x10"	MOSAICO SAHARA SCINTILLANTE HEX   P15
TAMAÑO DEL LIENZO: TRES LIENZOS 136x290 cm · GRAPHIC CHART SIZE: THREE GRAPHIC CHARTS 53,5"x114,2"	



SAND



PEARL



DARK GREY

| COLORES DISPONIBLES · AVAILABLE COLORS |





wall and floor: SAHARA SCINTILLANTE 120 SAND (60x120 cm), MOSAICO SAHARA SCINTILLANTE HEX SAND (29,3x25,4 cm).

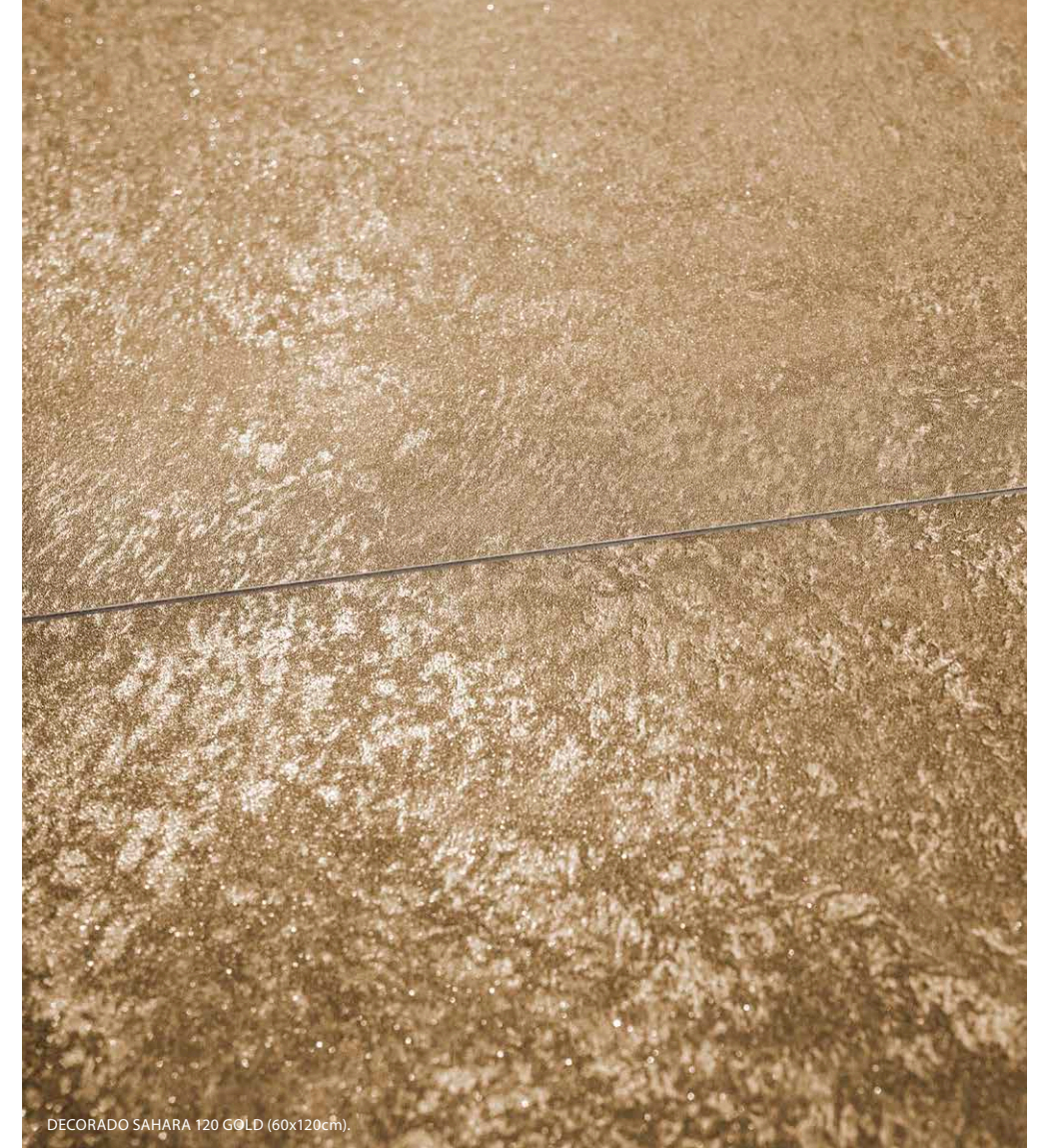

DECORADO SAHARA 120 GOLD (60x120cm).

| PIEZAS DECORATIVAS - DECORATIVE PIECES |

DECORADO SAHARA 120 | 60x120 cm | P83  
 Colocación y mantenimiento de baldosas cerámicas con recubrimiento PVD. Página 328.  
 Placement and maintenance of ceramic tiles with PVD coating. Page 329.

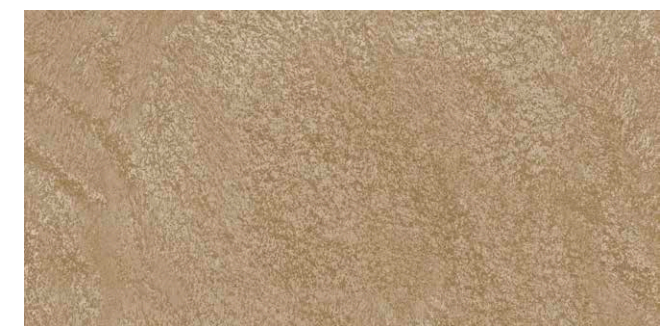

GOLD



SILVER





# SMART collection

| PORCELÁNICO · PORCELAIN |  
| RECTIFICADO · RECTIFIED |  
| DESTONIFICADO V1 · DESTONIFIED V1 |

60x60 cm 23,6"x23,6"	30x60 cm 11,8"x23,6"	30x30 cm 11,8"x11,8"

FORMATOS DISPONIBLES AVAILABLE FORMATS	ACABADO LAPADO METALIZADO METALLIC LAPATTO FINISH  10
60x60 cm · 23,6"x23,6"	SMART LUX 60   B46 (SMART LUX 60 WHITE   B37)
30x60 cm · 11,8"x23,6"	SMART LUX 3060   B46 (SMART LUX 3060 WHITE   B37)
30x30 cm · 11,8"x11,8"	MOSAICO SMART LUX T5   P71 (MOSAICO SMART LUX T5 WHITE   P60) 

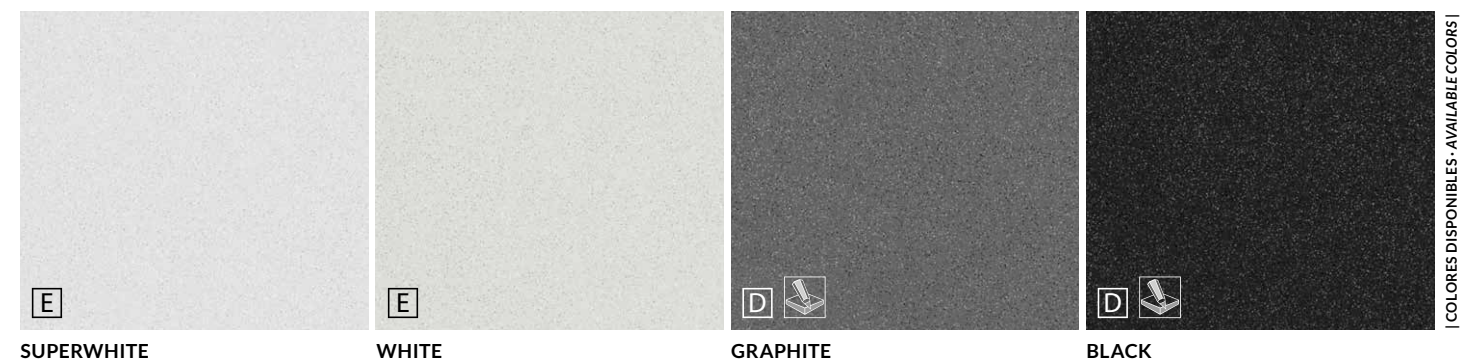





wall: SYNTHESIS 120 BLACK (60x120 cm).  
floor: SYNTHESIS 120 GREY (60x120 cm).

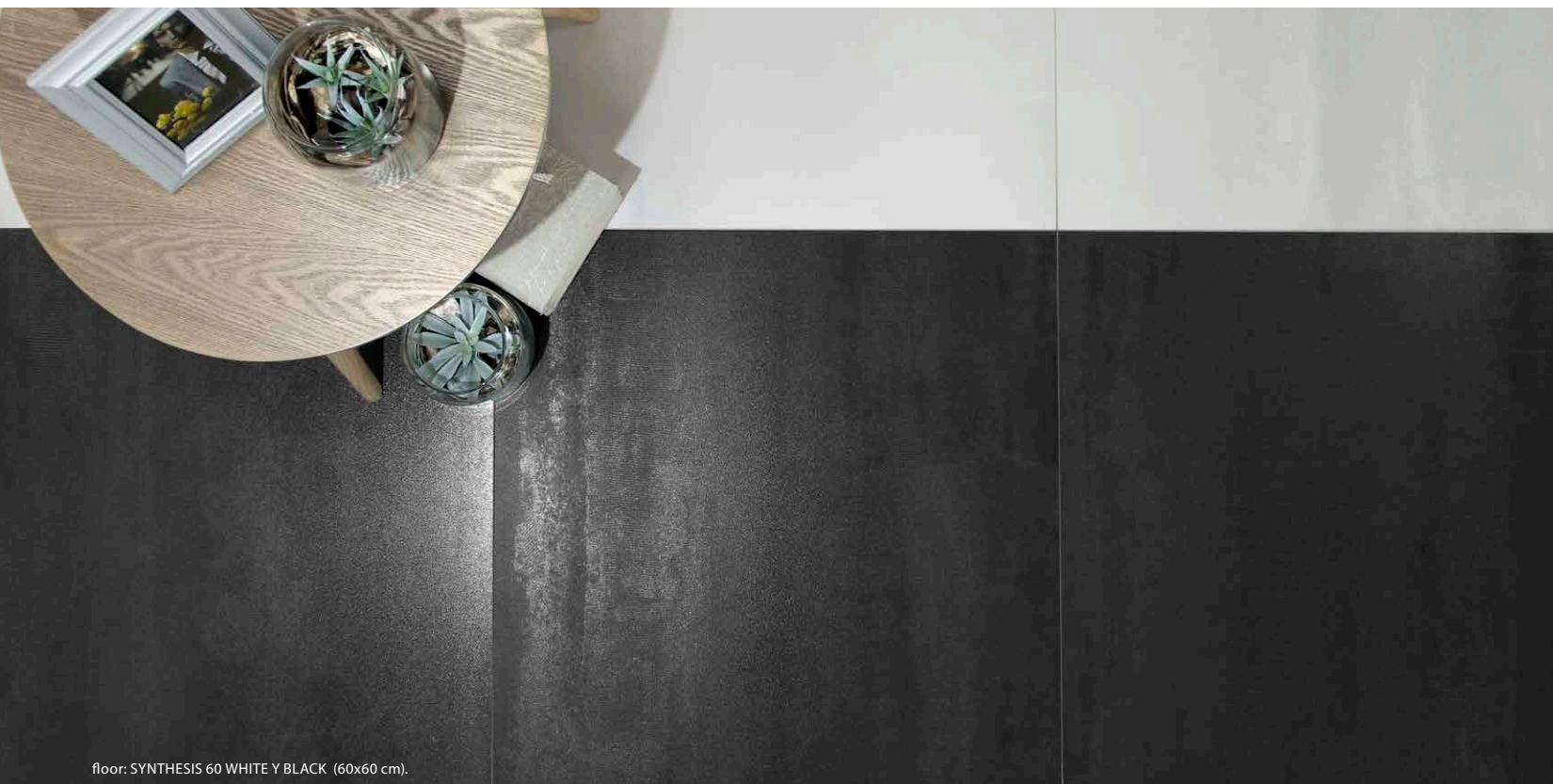

floor: SYNTHESIS 60 WHITE Y BLACK (60x60 cm).



# SYNTHESIS collection

| PORCELÁNICO · PORCELAIN | RECTIFICADO · RECTIFIED | DESTONIFICADO V2 · DESTONIFIED V2 |

| ESCALA DE LA GRÁFICA 1/2 · GRAPHIC SCALE 1/2 |

60x120 cm  
23,6"x47,2"

60x60 cm  
23,6"x23,6"

30x60 cm  
11,8"x23,6"

FORMATOS DISPONIBLES AVAILABLE FORMATS	ACABADO LAPADO MATE · MATT LAPATTO FINISH
60x120 cm · 23,6"x47,2"	SYNTHESIS 120   B83
60x60 cm · 23,6"x23,6"	SYNTHESIS 60   B37
30x60 cm · 11,8"x23,6"	SYNTHESIS 3060   B37
TAMAÑO DEL LIENZO: DOS LIENZOS 120x260 cm · GRAPHIC CHART SIZE: TWO GRAPHIC CHARTS 47,2"x102,4"	

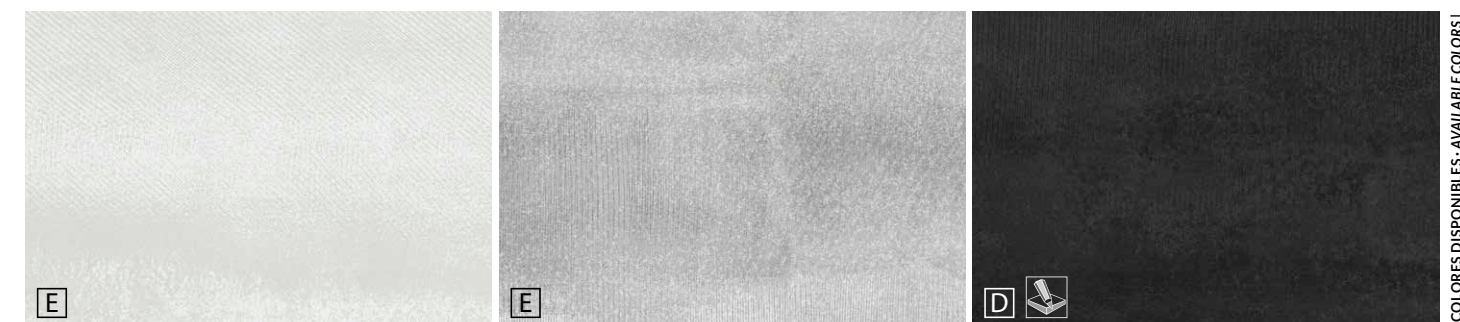

WHITE

GREY

BLACK

| COLORES DISPONIBLES · AVAILABLE COLORS |





wall: SYNTHESIS R90 GREY (30x90 cm), SYNTHESIS R90 MILL GREY (30x90 cm).  
floor: SYNTHESIS 60 GREY (60x60 cm).



SYNTHESIS R90 MILL WHITE (30x90cm).

# SYNTHESIS<sub>collection</sub>

| PASTA BLANCA · WHITE BODY | RECTIFICADO · RECTIFIED | DESTONIFICADO V2 · DESTONIFIED V2 |

| ESCALA DE LA GRÁFICA 1/2 · GRAPHIC SCALE 1/2 |

30x90 cm  
11,8"x35,4"

FORMATOS DISPONIBLES AVAILABLE FORMATS	ACABADO MATE · MATT FINISH 
30x90 cm · 11,8"x35,4"	SYNTHESIS R90   B42
	DECORADO SYNCRO R90   P74
	SYNTHESIS R90 MILL   B43 
TAMAÑO DEL LIENZO: DOS LIENZOS 120x260 cm · GRAPHIC CHART SIZE: TWO GRAPHIC CHARTS 47,2"x102,4"	

| PIEZAS DECORATIVAS · DECORATIVE PIECES |

DECORADO SYNCRO R90 | 30x90 cm | P74



WHITE

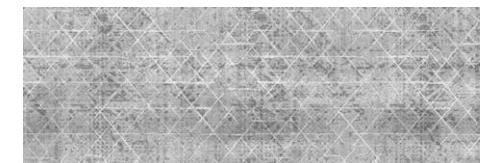

GREY



BLACK

SYNTHESIS R90 MILL | 30x90 cm | B43



WHITE



GREY



BLACK



WHITE



GREY



BLACK

| COLORES DISPONIBLES · AVAILABLE COLORS |





**MADERA | WOOD**

BARRICA	186 - 189
DEHLI	190 - 193
LAMEO · NEW	194 - 197
LEGNO	198 - 203
NAIROBI	204 - 207
NEBRASKA · NEW	208 - 211

**AZTECA**





wall: BARRICA 30 MIEL (30x120 cm).  
floor: BALI 60 TAUPE (60x60 cm).



wall: BARRICA 20 Y 30 CHOCOLATE (30x120 cm y 19,4x120 cm).  
floor: BALI 120 WHITE (60x120 cm).



# BARRICA<sub>collection</sub>

| PORCELÁNICO · PORCELAIN | RECTIFICADO · RECTIFIED | DESTONIFICADO V3 · DESTONIFIED V3 |



ESCALA DE LA GRÁFICA 1/2 · GRAPHIC SCALE 1/2 |

30x120 cm  
11,8"x47,2"

19,4x120 cm  
7,6"x47,2"

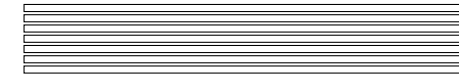
18,5x120 cm  
7,3"x47,2"



FORMATOS DISPONIBLES AVAILABLE FORMATS	ACABADO NATURAL · NATURAL FINISH 	ACABADO ANTIDESLIZANTE · SLIP RESISTANCE FINISH 
30x120 cm · 11,8"x47,2"	BARRICA 30   B89	BARRICA DRY 30   B92 (nuez, miel, gris)
19,4x120 cm · 7,6"x47,2"	BARRICA 20   B87	BARRICA DRY 20   B91 (nuez, miel, gris)
18,5x120 cm · 7,3"x47,2"	SLATS BARRICA 120   P90 	---
Nº DISEÑOS POR FORMATO · Nº DESIGNS BY FORMAT:   30x120: 8   19,4x120: 12		



CHOCOLATE

NUEZ

MIEL

BONE

GRIS

COLORES DISPONIBLES · AVAILABLE COLORS |





BARRICA 20 Y 30 GRIS (30x120 cm y 19,4x120 cm).



wall: BALTR90 GREY (30x90 cm).  
floor: BARRICA 20 Y 30 NUEZ (30x120 cm y 19,4x120 cm).





floor: DELHI 20 ASH (19,4x120 cm).

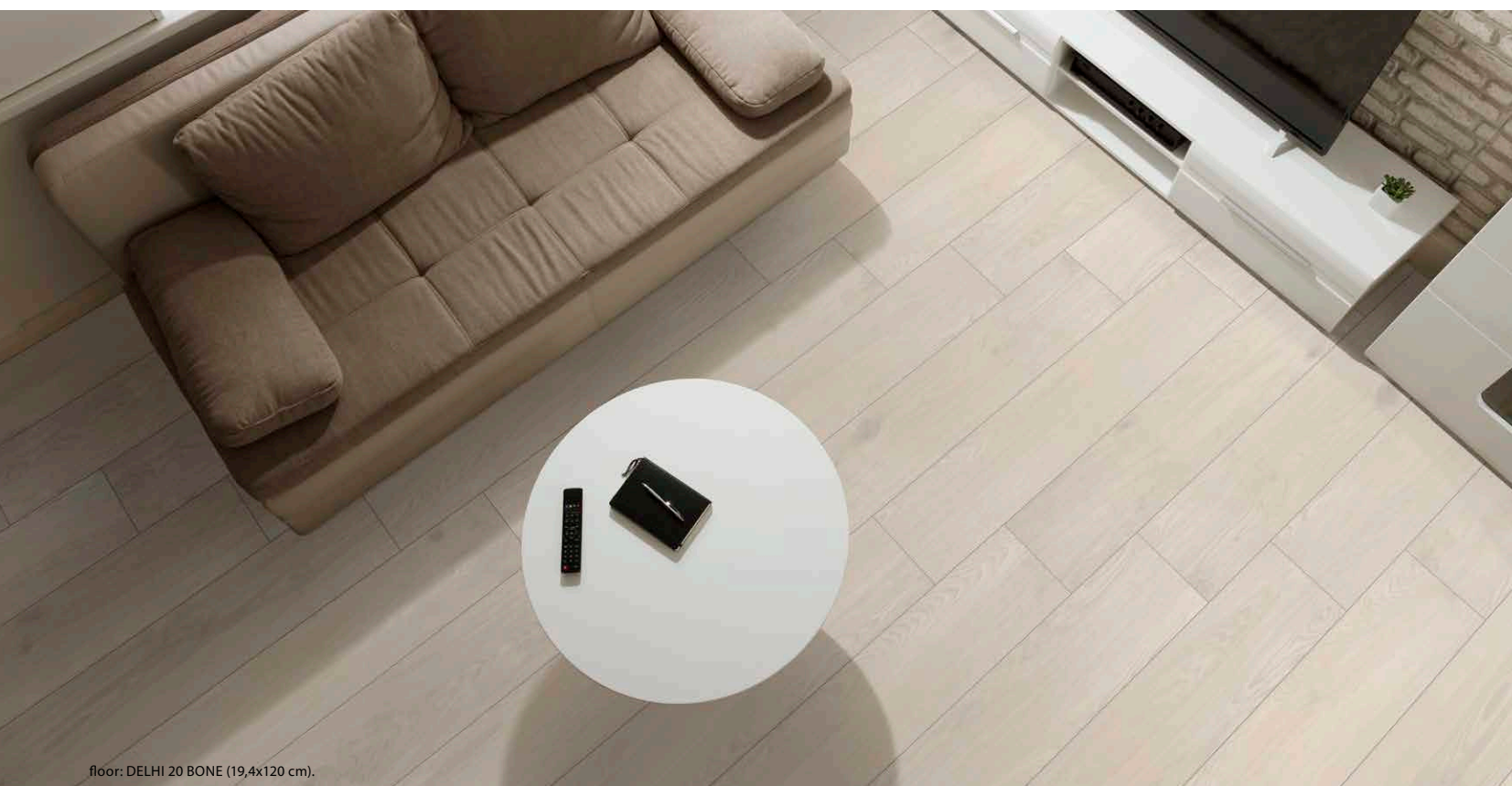

floor: DELHI 20 BONE (19,4x120 cm).



# DELHI

collection

| PORCELÁNICO · PORCELAIN | RECTIFICADO · RECTIFIED | DESTONIFICADO V3 · DESTONIFIED V3 |

ESCALA DE LA GRÁFICA 1/2 - GRAPHIC SCALE 1/2 |

19,4x120 cm  
7,6"x47,2"

<p>FORMATOS DISPONIBLES AVAILABLE FORMATS</p>	<p>ACABADO NATURAL · NATURAL FINISH</p>
<p>19,4x120 cm · 7,6"x47,2"</p>	<p>DELHI 20   B87</p>
<p>Nº DISEÑOS POR FORMATO · Nº DESIGNS BY FORMAT:   19,4x120: 18  </p>	



COLORES DISPONIBLES · AVAILABLE COLORS |





floor: DELHI 20 ALMOND (19,4x120 cm).

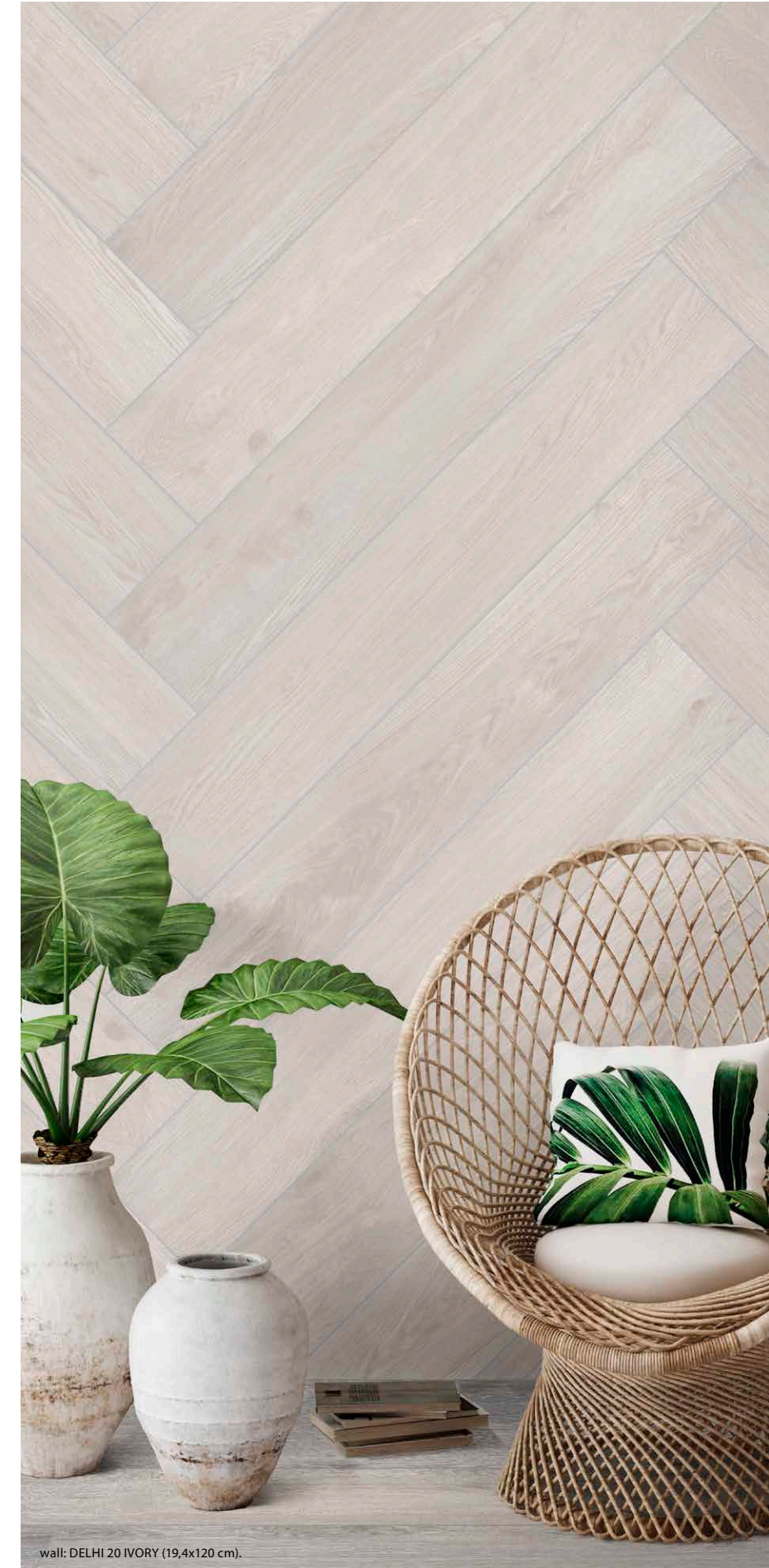

wall: DELHI 20 IVORY (19,4x120 cm).





wall: DECORADO LAMEO R120 ROVERE (40x120 cm), PORTOPETRO R90 SALT SAND (30x90 cm), PORTOPETRO R90 SAND (30x90 cm).

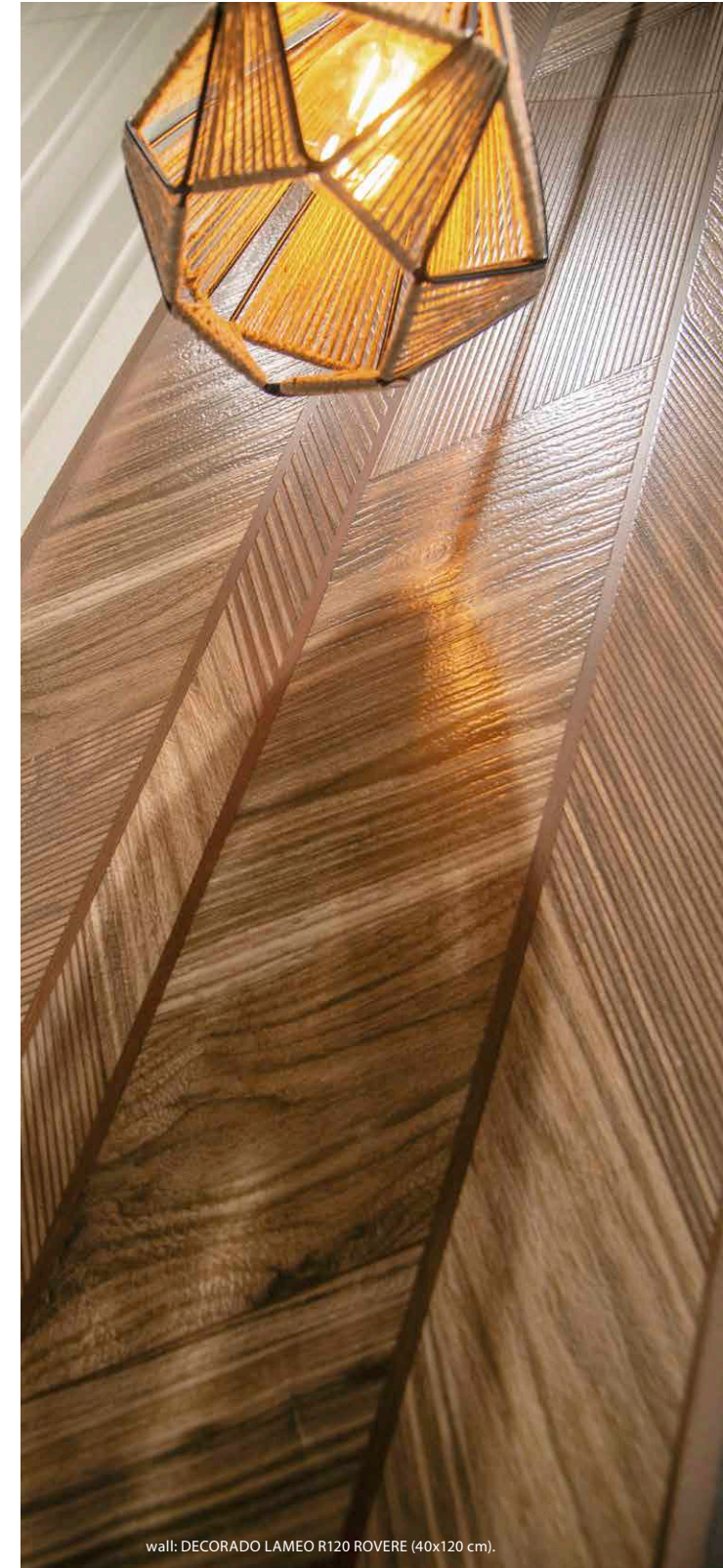

wall: DECORADO LAMEO R120 ROVERE (40x120 cm).

# LAMEO collection

| PASTA BLANCA · WHITE BODY |  
 | RECTIFICADO · RECTIFIED |  
 | DESTONIFICADO V3 · DESTONIFIED V3 |

40x120 cm  
 15,7"x47,2"

FORMATOS DISPONIBLES  
 AVAILABLE FORMATS

ACABADO NATURAL · NATURAL FINISH



40x120 cm · 15,7"x47,2"

DECORADO LAMEO R120 | B95

Nº DISEÑOS POR FORMATO · Nº DESIGNS BY FORMAT: | 40x120: 6 |

## | PIEZAS · PIECES |

DECORADO LAMEO R120 | 40x120 cm | B95

Seis piezas diferentes. Unidad de venta: 1 caja. Six different pieces. Sales unit: 1 box.



ROVERE

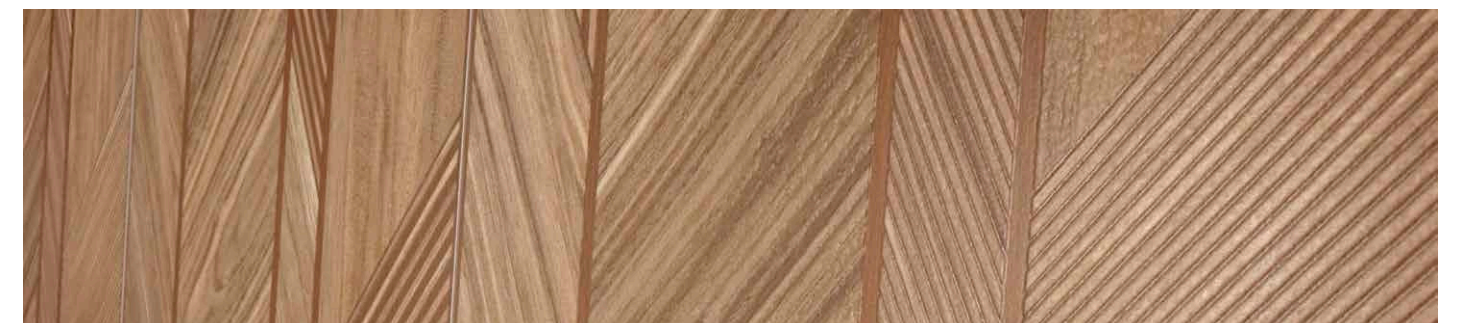





wall: DECORADO LAMEO R120 ROVERE (40x120 cm), DECORADO AZAI R90 SAND (30x90 cm).  
floor: KALEIDOSCOPE 120 WHITE (60x120 cm).



wall: DECORADO LAMEO R120 ROVERE (40x120 cm), CALACATTA GOLD R120 MATT (40x120 cm).  
floor: CALACATTA GOLD NAT 120 (60x120 cm).





floor: LEGNO 20 y 30 NOCE y ROVERE (19,4x120 y 30x120 cm).



wall: LEGNO R90 TRAIL BETULLA (30x90 cm), DECORADO BLOOM R90 WHITE (30x90 cm).  
 floor: LEGNO 20 y 30 BETULLA (19,4x120 y 30x120 cm).



# LEGNO<sub>collection</sub>

| PORCELÁNICO · PORCELAIN |  
 | RECTIFICADO · RECTIFIED |  
 | DESTONIFICADO V2 · DESTONIFIED V2 |

ESCALA DE LA GRÁFICA 1/2 - GRAPHIC SCALE 1/2

30x120 cm  
 11,8"x47,2"

19,4x120 cm  
 7,6"x47,2"

18,5x120 cm  
 7,3"x47,2"

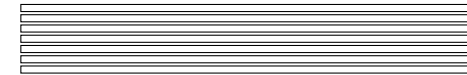

FORMATOS DISPONIBLES AVAILABLE FORMATS	ACABADO NATURAL · NATURAL FINISH 	ACABADO ANTIDESLIZANTE · SLIP RESISTANCE FINISH 
30x120 cm · 11,8"x47,2"	LEGNO 30   B89	LEGNO DRY 30   B92
19,4x120 cm · 7,6"x47,2"	LEGNO 20   B87	LEGNO DRY 20   B91
18,5x120 cm · 7,3"x47,2"	SLATS LEGNO 120   P90 	---
TAMAÑO DEL LIENZO: TRES LIENZOS 100x200 cm · GRAPHIC CHART SIZE: THREE GRAPHIC CHARTS 39,4"x78,7"		



NOCE ROVERE FAGGIO BETULLA

COLORES DISPONIBLES · AVAILABLE COLORS





wall: LEGNO R90 TRAIL FAGGIO (30x90 cm).  
floor: CERVINO LUX 120 BLACK (60x120 cm).



wall: SHELLSTONE 120 GREIGE (60x120 cm).  
floor: LEGNO 20 y DRY 20 FAGGIO (19,4x120 cm), LEGNO 30 y DRY 30 FAGGIO (30x120 cm).



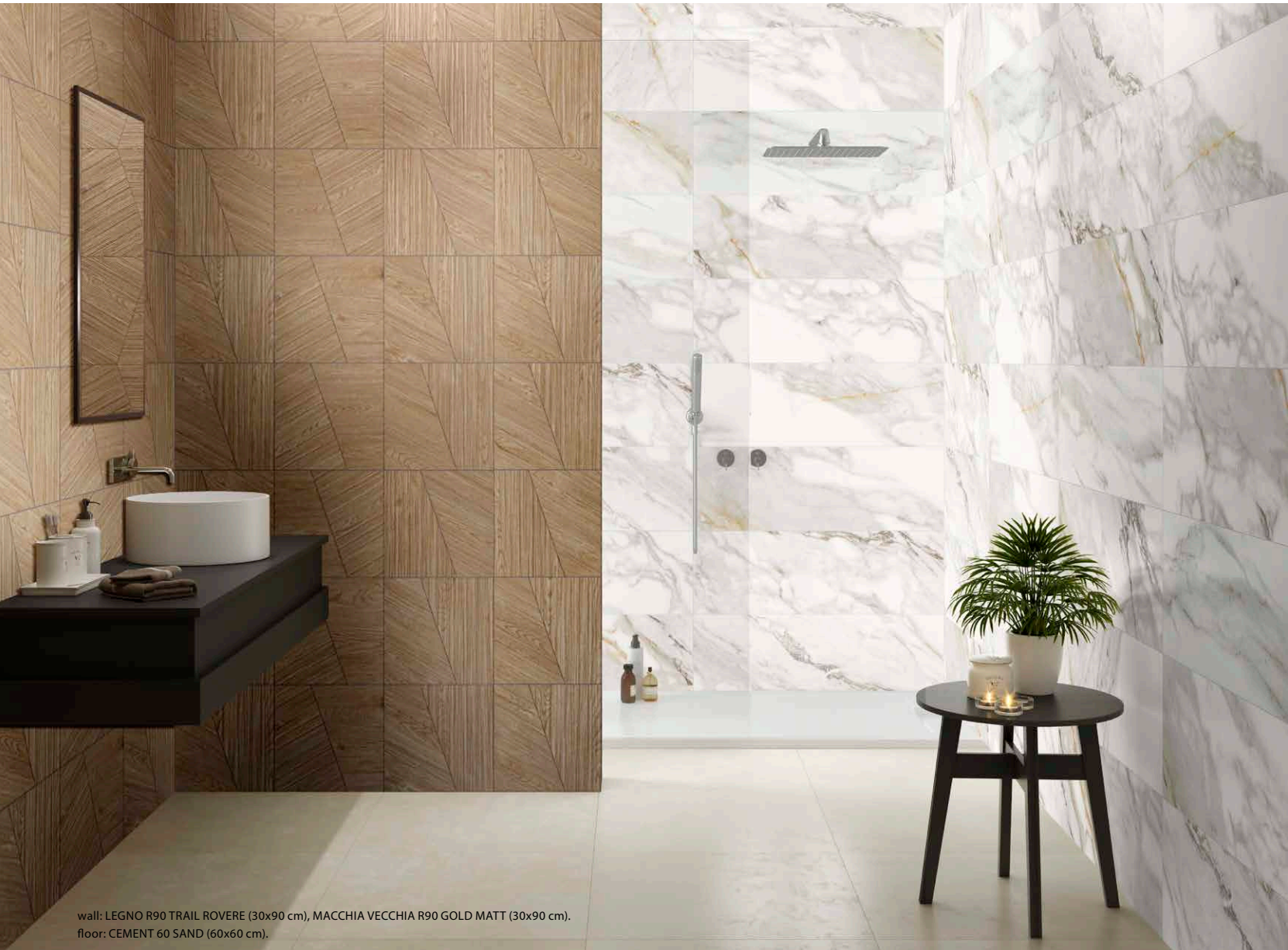

wall: LEGNO R90 TRAIL ROVERE (30x90 cm), MACCHIA VECCHIA R90 GOLD MATT (30x90 cm).  
floor: CEMENT 60 SAND (60x60 cm).

# LEGNO collection

| PASTA BLANCA · WHITE BODY | RECTIFICADO · RECTIFIED | DESTONIFICADO V2 · DESTONIFIED V2 |

| PIEZAS · PIECES |

LEGNO R90 TRAIL | 30x90 cm | B43



BETULLA

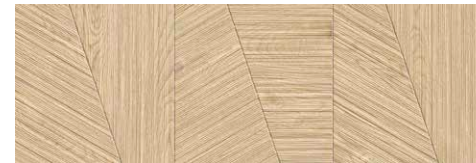

FAGGIO



ROVERE

30x90 cm  
11,8"x35,4"

<p>FORMATOS DISPONIBLES AVAILABLE FORMATS</p>	<p>ACABADO MATE · MATT FINISH</p>
<p>30x90 cm · 11,8"x35,4"</p>	<p>LEGNO R90 TRAIL   B43</p>
<p>Nº DISEÑOS POR FORMATO · Nº DESIGNS BY FORMAT:   30x90: 4  </p>	



wall: LEGNO R90 TRAIL BETULLA (30x90 cm), MACCHIA VECCHIA R90 GOLD MATT (30x90 cm).



LEGNO R90 TRAIL ROVERE (30x90 cm).





wall: CALACATTA GOLD NAT 60 Y 120 (60x60 cm, 60x120 cm).  
 floor: NAIROBI 20 GRIS (19,4x120 cm).



floor: NAIROBI DRY 20 GRIS (19,4x120 cm).



# NAIROBI collection

| PORCELÁNICO · PORCELAIN | RECTIFICADO · RECTIFIED | DESTONIFICADO V3 · DESTONIFIED V3 |

ESCALA DE LA GRÁFICA 1/2 - GRAPHIC SCALE 1/2 I

19,4x120 cm  
 7,6"x47,2"

24,5x27,8 cm  
 9,6"x10,9"

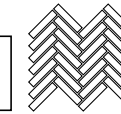

FORMATOS DISPONIBLES AVAILABLE FORMATS	ACABADO NATURAL · NATURAL FINISH	ACABADO ANTIDESLIZANTE · SLIP RESISTANCE FINISH
19,4x120 cm · 7,6"x47,2"	NAIROBI 20   B87	NAIROBI DRY 20   B91
24,5x27,8 cm · 9,6"x10,9"	MOSAICO NAIROBI M   P84 	---

TAMAÑO DEL LIENZO: DOS LIENZOS 120x260 cm · GRAPHIC CHART SIZE: TWO GRAPHIC CHARTS 47,2"x102,4"



**E**  
 ROBLE



**E**  
 HAYA



**E**  
 GRIS

COLORES DISPONIBLES · AVAILABLE COLOURS I





wall: NAIORBI 20 ROBLE (19,4x120 cm), UNIK R120 WHITE MATT (40x120 cm).  
floor: NAIORBI 20 ROBLE (19,4x120 cm).



floor: NAIORBI 20 HAYA (19,4x120 cm).



wall: NAIORBI 20 HAYA (19,4x120 cm).  
floor: NAIORBI 20 ROBLE (19,4x120 cm).





wall: KALEIDOSCOPE 120 CREAM (60x120 cm), COLORS 5x25 DARK GREY GLOSSY (5x25 cm).  
floor: CHEVRON NEBRASKA 60 NOGAL (9x50 cm).



floor: NEBRASKA DRY 30 NOGAL (30x120 cm).



# NEBRASKA<sub>collection</sub>

| PORCELÁNICO · PORCELAIN | RECTIFICADO · RECTIFIED | DESTONIFICADO V2 · DESTONIFIED V2 |

ESCALA DE LA GRÁFICA 1/2 - GRAPHIC SCALE 1/2 |

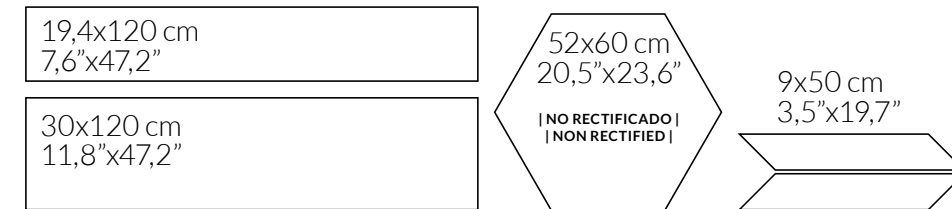

FORMATOS DISPONIBLES AVAILABLE FORMATS	ACABADO NATURAL · NATURAL FINISH 	ACABADO ANTIDESLIZANTE · SLIP RESISTANCE FINISH 
30x120 cm · 11,8" x 47,2"	NEBRASKA 30   B89	NEBRASKA DRY 30   B92
19,4x120 cm · 7,6" x 47,2"	NEBRASKA 20   B87	NEBRASKA DRY 20   B91
52x60 cm · 20,5" x 23,6"	NEBRASKA HEX60 JENGA   B14	---
9x50 cm · 3,5" x 19,7"	CHEVRON NEBRASKA 60   P82	---
Nº DISEÑOS POR FORMATO · Nº DESIGNS BY FORMAT:   30x120: 6   19,4x120: 9   52x60: 7		



NOGAL

ROBLE

MIEL

COLORES DISPONIBLES · AVAILABLE COLORS |



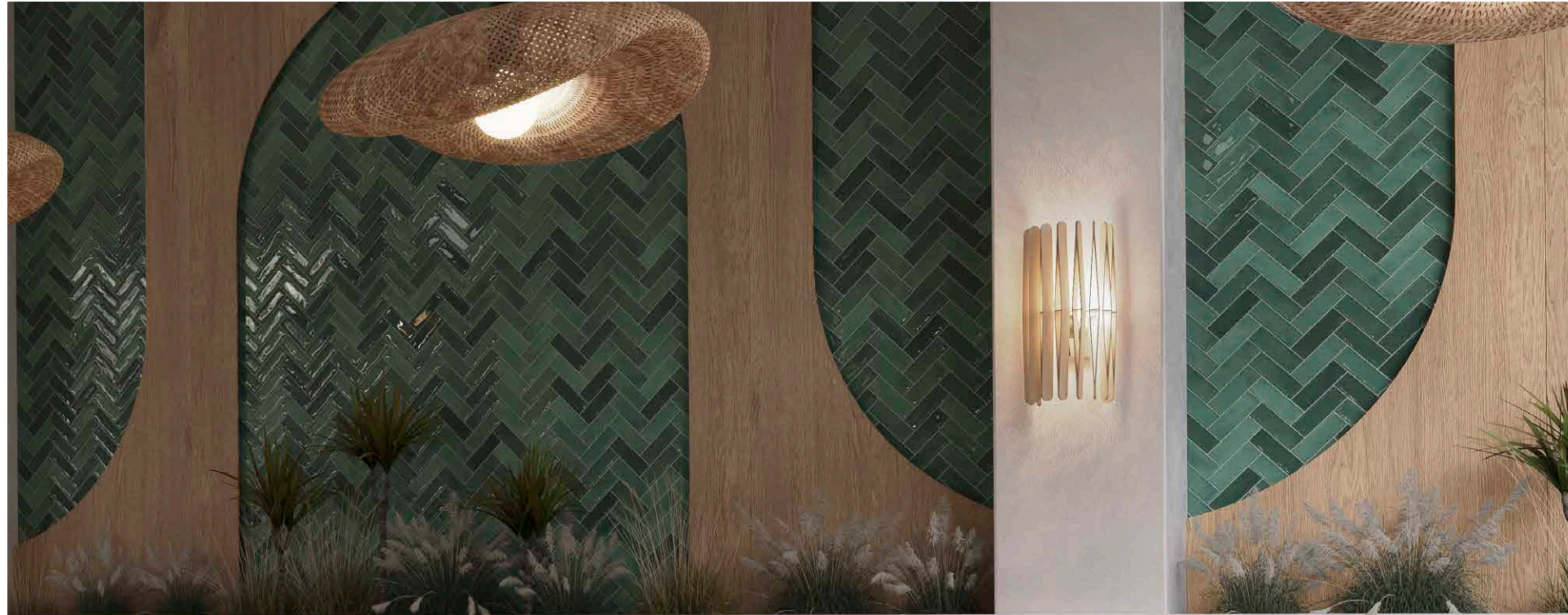

wall: TURQUETA 5x15 GREEN GLOSSY (5x15 cm), TURQUETA 5x15 GREEN MATT (5x15 cm).  
 floor: NEBRASKA HEX60 JENGA ROBLE (52x60 cm).

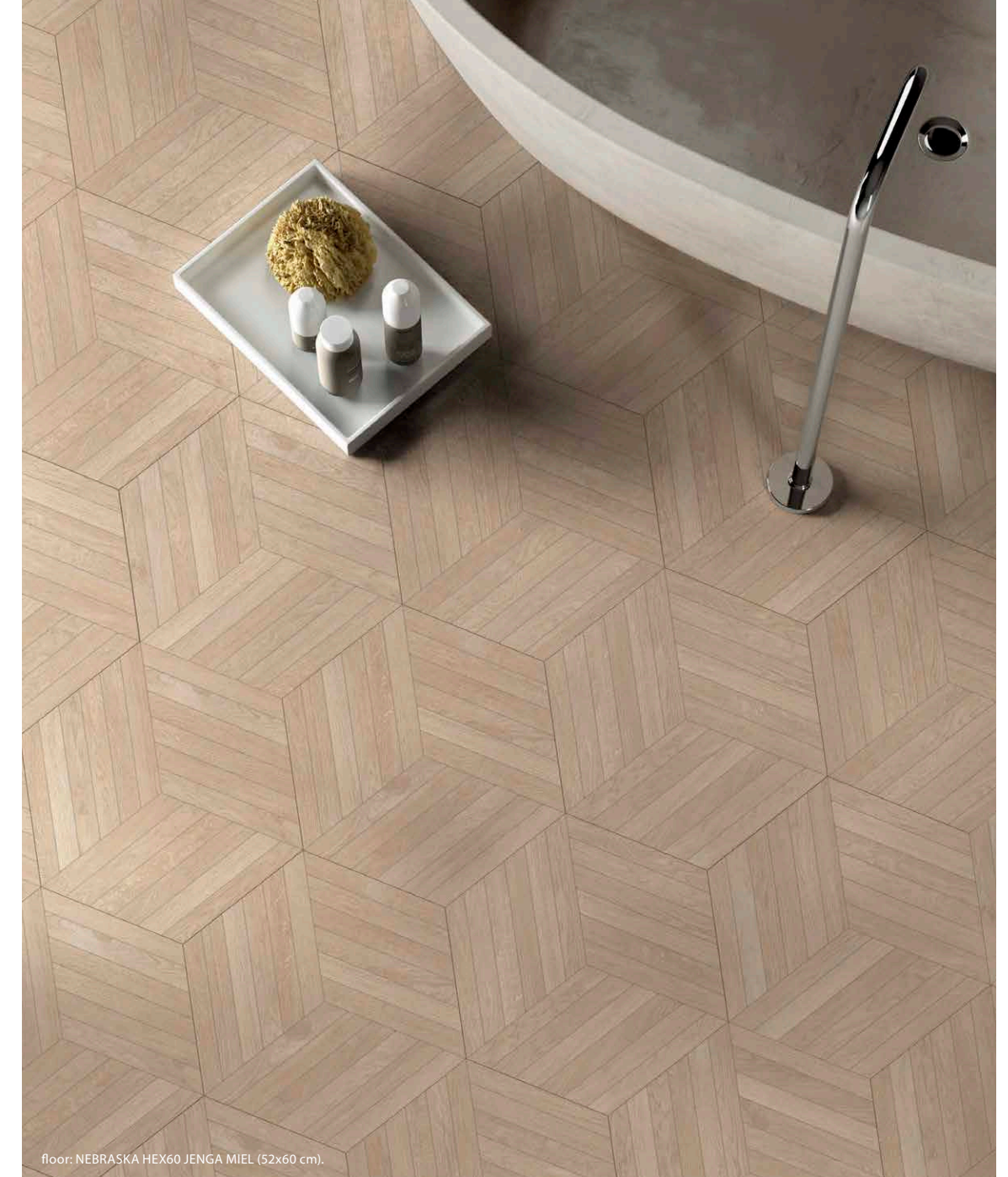

floor: NEBRASKA HEX60 JENGA MIEL (52x60 cm).

| PIEZAS DECORATIVAS · DECORATIVE PIECES |

NEBRASKA HEX60 JENGA | 52x60 cm | B14



**NOGAL**  
 Rejunte recomendado Antracite.  
 Recommended grouting Antracite.



**ROBLE**  
 Rejunte recomendado Antracite.  
 Recommended grouting Antracite.



**MIEL**  
 Rejunte recomendado Cement.  
 Recommended grouting Cement.





## MÁRMOL | MARBLE

AMAZONAS -NEW	214 - 217
CALACATTA -NEW	218 - 223
CERVINO	224 - 227
CRISTALLO -NEW	228 - 233
DA VINCI	234 - 235
DUBAI	236 - 237
FONTANA	238 - 239
JASPER	240 - 241
MACCHIA VECCHIA	242 - 245
MARBLEFULL · BOMBAY	246 - 249
MARBLEFULL · INVISIBLE	250 - 253
MARBLEFULL · PATAGONIA	254 - 257
NAGOYA	258 - 263
ONYX	264 - 267
PARADOX -NEW	268 - 273
PASSION	274 - 275
PERLA VENATA -NEW	276 - 281
TRAVERTINE · LACIO	282 - 285
TRAVERTINE · TIVOLI	286 - 289
VICHY -NEW	290 - 293
VULCANO	294 - 297

**AZTECA**





floor: AMAZONAS 9090 RAIN (90x90 cm).



wall: AMAZONAS LUX 120 RIVER (60x120 cm), AURA 6x25 GRAPHITE (6,2x25 cm).  
floor: AMAZONAS LUX 120 RIVER (60x120 cm).



# AMAZONAS<sub>collection</sub>

| PORCELÁNICO · PORCELAIN | RECTIFICADO · RECTIFIED | DESTONIFICADO V3 · DESTONIFIED V3 |

ESCALA DE LA GRÁFICA 1/2 · GRAPHIC SCALE 1/2 |

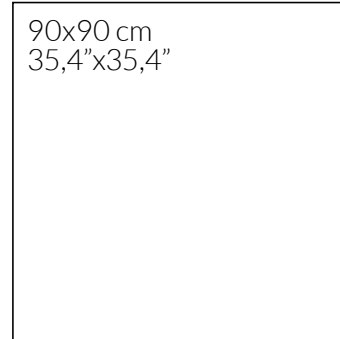

90x90 cm  
35,4"x35,4"

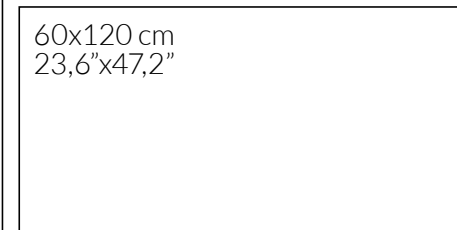

60x120 cm  
23,6"x47,2"

FORMATOS DISPONIBLES AVAILABLE FORMATS	ACABADO NATURAL NATURAL FINISH 	ACABADO LAPADO BRILLO GLOSSY LAPATTO FINISH 
90x90 cm · 35,4"x35,4"	AMAZONAS 9090   B50	---
60x120 cm · 23,6"x47,2"	AMAZONAS 120   B85	AMAZONAS LUX 120   B83
Nº DISEÑOS POR FORMATO · Nº DESIGNS BY FORMAT:   90x90: 9   60x120: 12		

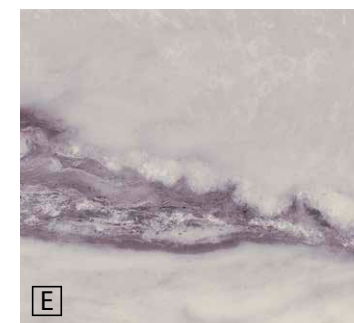

E

WILD

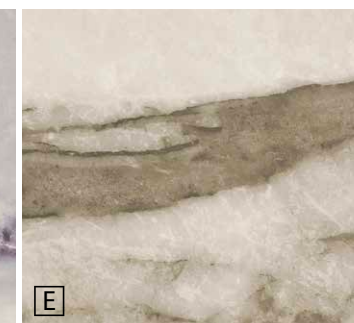

E

FOREST

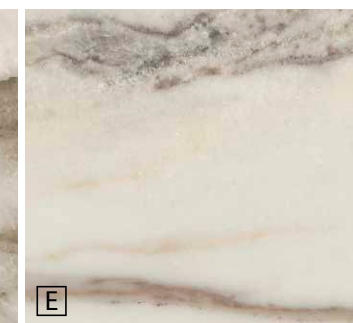

E

RAIN

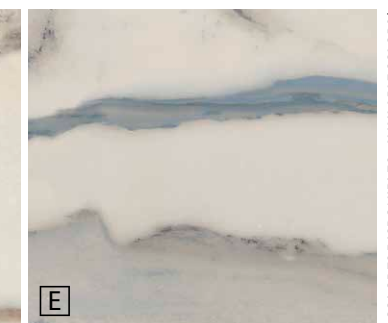

E

RIVER

COLORES DISPONIBLES · AVAILABLE COLORS |





wall: AMAZONAS 120 FOREST (60x120 cm), AURA 6x25 SAGE Y WHITE (6,2x25 cm).  
floor: AMAZONAS 120 FOREST (60x120 cm).





floor: CALACATTA GOLD DRY 120 (60x120 cm).

# CALACATTA collection

| PORCELÁNICO · PORCELAIN | RECTIFICADO · RECTIFIED | DESTONIFICADO V2 · DESTONIFIED V2 |

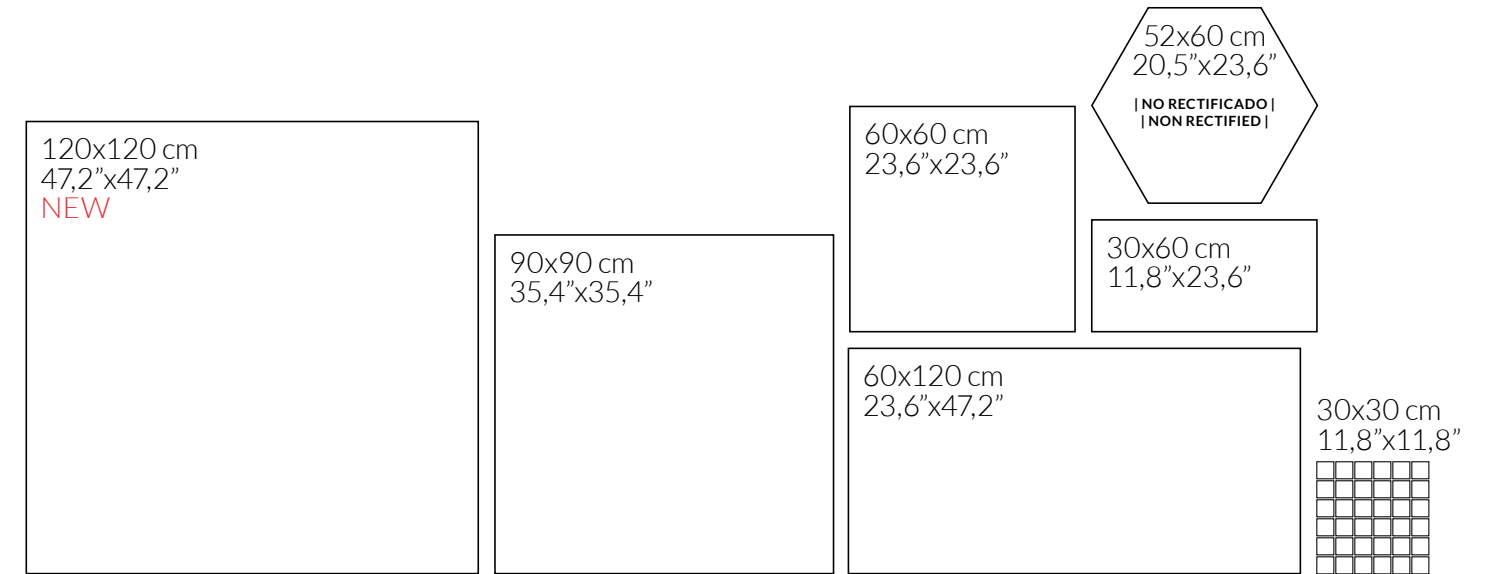

wall and floor: CALACATTA GOLD NAT HEX60 (52x60 cm).

FORMATOS DISPONIBLES AVAILABLE FORMATS	ACABADO NATURAL NATURAL FINISH	ACABADO ANTIDESLIZANTE SLIP RESISTANCE FINISH	ACABADO LAPADO BRILLO GLOSSY LAPATTO FINISH
120x120 cm · 47,2"x47,2"	CALACATTA NAT 120x120   B04 (gold)	---	---
90x90 cm · 35,4"x35,4"	CALACATTA NAT 9090   B50	CALACATTA DRY 9090   B51	CALACATTA LUX 9090   B52
60x120 cm · 23,6"x47,2"	CALACATTA NAT 120   B85	CALACATTA DRY 120   B86	CALACATTA LUX 120   B83
60x60 cm · 23,6"x23,6"	CALACATTA NAT 60   B35	CALACATTA DRY 60   B36	CALACATTA LUX 60   B37
52x60 cm · 20,5"x23,6"	CALACATTA NAT HEX60   B12	CALACATTA DRY HEX60   B13	---
30x60 cm · 11,8"x23,6"	CALACATTA NAT 3060   B35	CALACATTA DRY 3060   B36	CALACATTA LUX 3060   B37
30x30 cm · 11,8"x11,8"	MOSAICO CALACATTA NAT T5   P70	---	MOSAICO CALACATTA LUX T5   P60
Nº DISEÑOS POR FORMATO · Nº DESIGNS BY FORMAT:   90x90: 12   60x120: 16   60x60: 32   52x60: 16   30x60: 64			

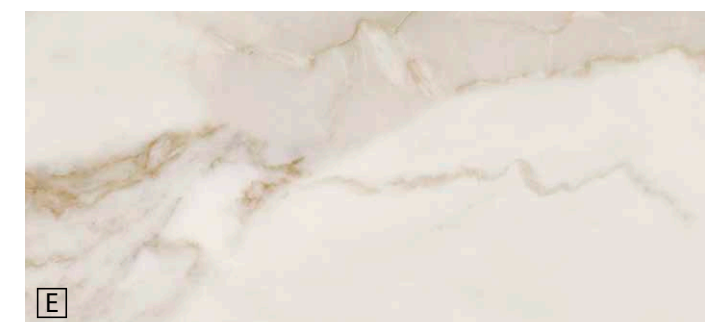

E  
GOLD

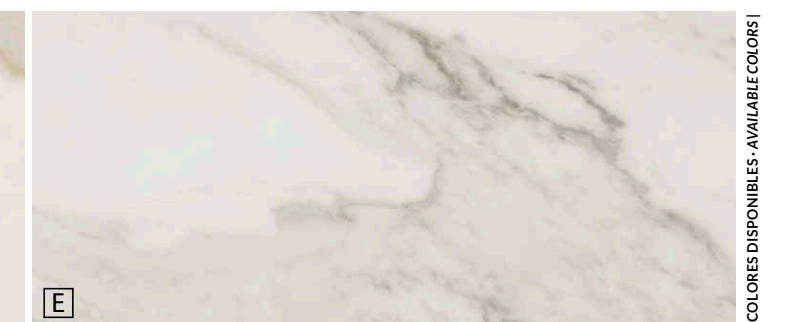

E  
SILVER

COLORES DISPONIBLES · AVAILABLE COLOURS





wall and floor: CALACATTA SILVER NAT HEX60 (52x60 cm).



wall: CALACATTA SILVER LUX 120 (60x120 cm).  
floor: CALACATTA SILVER LUX 9090 (90x90 cm).



floor: CALACATTA GOLD NAT 120x120 (120x120 cm).





wall: CALACATTA SILVER R90 GLOSSY (30x90 cm), CALACATTA SILVER R90 BOB GLOSSY (30x90 cm).  
 floor: CALACATTA SILVER LUX 60 (60x60 cm), MOSAICO CALACATTA SILVER LUX T5 (30x30 cm).











# CALACATTA collection

| PASTA BLANCA · WHITE BODY | RECTIFICADO · RECTIFIED | DESTONIFICADO V2 · DESTONIFIED V2 |

40x120 cm  
15,7"x47,2"

30x90 cm  
11,8"x35,4"

30x60 cm  
11,8"x23,6"

FORMATOS DISPONIBLES AVAILABLE FORMATS	ACABADO MATE · MATT FINISH   	ACABADO BRILLO · GLOSSY FINISH  
40x120 cm · 15,7"x47,2"	CALACATTA R120 MATT   B94 (gold)	CALACATTA R120 GLOSSY   B97 (gold)
	CALACATTA R120 TOP MATT   B95 (gold) 	CALACATTA R120 BOB GLOSSY   B98 (gold) 
30x90 cm · 11,8"x35,4"	CALACATTA R90 MATT   B42	CALACATTA R90 GLOSSY   B42
	CALACATTA R90 TOP MATT   B43 	CALACATTA R90 BOB GLOSSY   B43 
30x60 cm · 11,8"x23,6"	CALACATTA R3060 RECT. MATT   B65	CALACATTA R3060 RECT. GLOSSY   B65
	CALACATTA R3060 RECT. WALL MATT   B67 	CALACATTA R3060 RECT. VALS GLOSSY   B67 

Nº DISEÑOS POR FORMATO · Nº DESIGNS BY FORMAT: | 40x120: 14 | 30x90: 26 | 30x60: 17 |

## PIEZAS DECORATIVAS · DECORATIVE PIECES |

CALACATTA R90 TOP MATT | 30x90 cm | **B43**  
 CALACATTA R90 BOB GLOSSY | 30x90 cm | **B43**  
 Tres piezas diferentes. Unidad de venta: 1 caja. - Three different pieces. Sales unit: 1 box.



GOLD



SILVER

CALACATTA R3060 RECT. WALL MATT | 30x60 cm | **B67**  
 Tres piezas diferentes. Unidad de venta: 1 caja. - Three different pieces. Sales unit: 1 box.



GOLD



SILVER

CALACATTA R3060 RECT. VALS GLOSSY | 30x60 cm | **B67**



GOLD



SILVER

CALACATTA R120 TOP MATT | 40x120 cm | **B95**  
 CALACATTA R120 BOB GLOSSY | 40x120 cm | **B98**  
 Tres piezas diferentes. Unidad de venta: 1 caja. - Three different pieces. Sales unit: 1 box.



GOLD



GOLD

SILVER

COLORES DISPONIBLES · AVAILABLE COLORS |

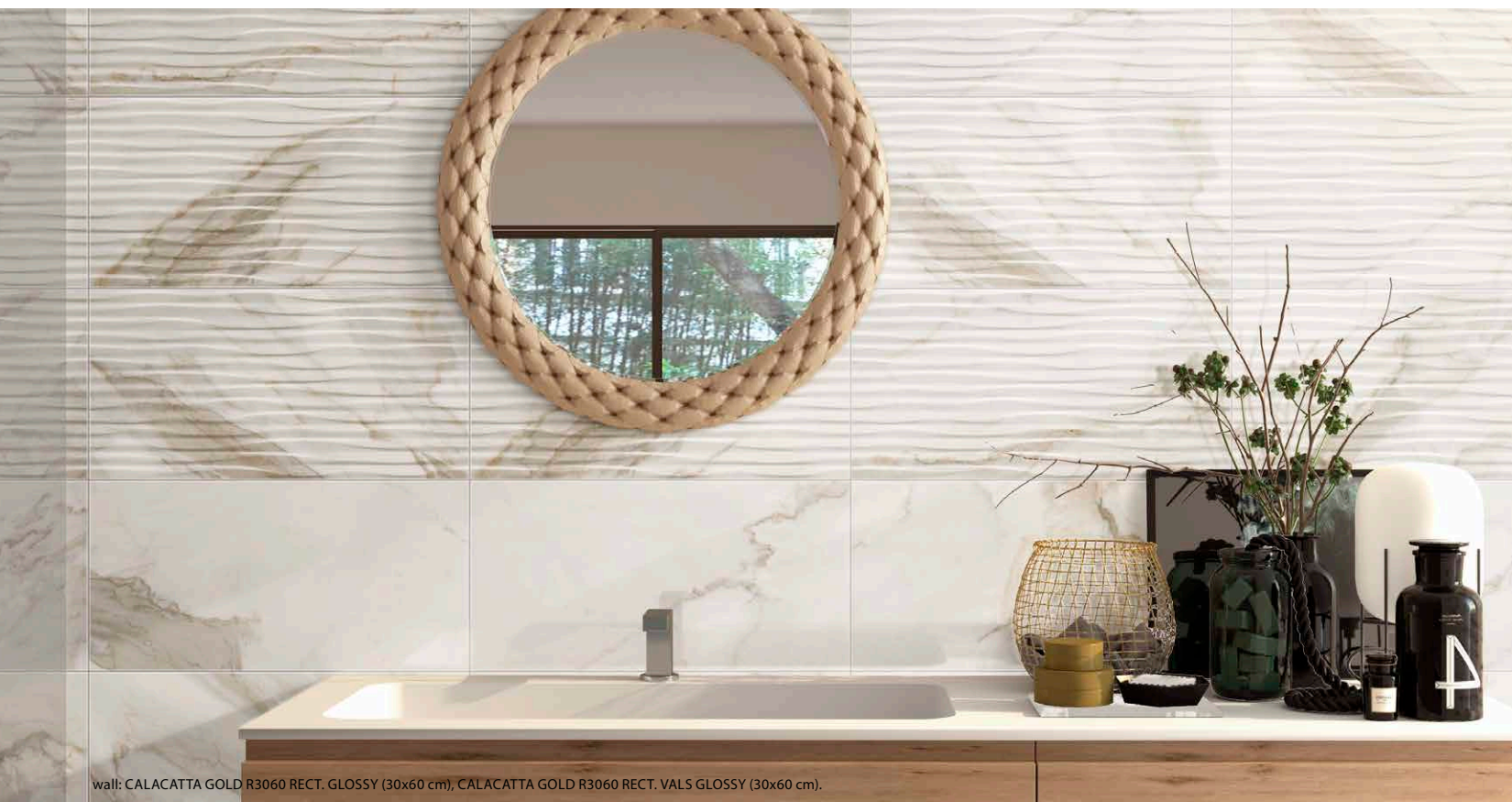

wall: CALACATTA GOLD R3060 RECT. GLOSSY (30x60 cm), CALACATTA GOLD R3060 RECT. VALS GLOSSY (30x60 cm).





wall: CERVINO LUX 120 WHITE (60x120 cm), BOMBAY LUX 120 (60x120 cm), DELHI 20 CHOCOLATE (19,4x120 cm).  
floor: CERVINO LUX 120 WHITE (60x120 cm).



wall: CERVINO LUX 120 WHITE (60x120 cm), LISTELO 90 FRAME ACERO (9,3x90 cm).



# CERVINO

collection

| PORCELÁNICO · PORCELAIN · RECTIFICADO · RECTIFIED | DESTONIFICADO V3 · DESTONIFIED V3 |

ESCALA DE LA GRÁFICA 1/2 - GRAPHIC SCALE 1/2 |

60x120 cm 23,6"x47,2"	60x60 cm 23,6"x23,6"	30x30 cm 11,8"x11,8"	27,4x29,8 cm 10,8"x11,7"
		30x60 cm 11,8"x23,6"	

FORMATOS DISPONIBLES AVAILABLE FORMATS	ACABADO LAPADO BRILLO GLOSSY LAPATTO FINISH
60x120 cm · 23,6"x47,2"	CERVINO LUX 120   B83
60x60 cm · 23,6"x23,6"	CERVINO LUX 60   B37
30x60 cm · 11,8"x23,6"	CERVINO LUX 3060   B37
30x30 cm · 11,8"x11,8"	MOSAICO CERVINO LUX T5   P60
27,4x29,8 cm · 10,8"x11,7"	MOSAICO CERVINO LUX PICKET   P15 (white, black, mix)
TAMAÑO DEL LIENZO: 133x282 cm · GRAPHIC CHART SIZE: 52,4"x111"	

**| PIEZAS DECORATIVAS · DECORATIVE PIECES |**

MOSAICO CERVINO LUX PICKET | 27,4x29,8 cm | P15



MIX

Decoración complementaria recomendada: Recommended complementary decoration pieces:

LISTELO 90 FRAME | 9,3x90 cm | P25

Tres piezas diferentes. Unidad de venta: 1 caja. Three different pieces. Sales unit: 1 box.



COBRE



ACERO

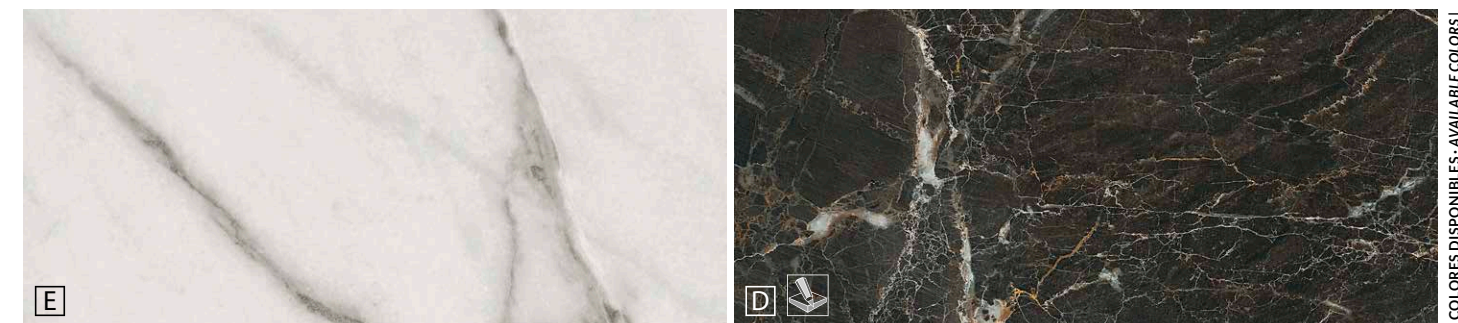

E WHITE

D BLACK

COLORES DISPONIBLES - AVAILABLE COLORS |





wall: CERVINO LUX 120 BLACK (60x120 cm),  
LISTELO 90 FRAME COBRE (9,3x90 cm).



wall: CERVINO LUX 120 BLACK (60x120 cm), MOSAICO CERVINO LUX PICKET BLACK (27,4x29,8 cm), LEGNO R90 TRAIL FAGGIO (30x90 cm).  
floor: CERVINO LUX 120 BLACK (60x120 cm).





wall: CRISTALLO LUX 120 GRIGIO (60x120 cm),  
floor: NEBRASKA 30 ROBLE (30x120 cm).



wall and floor: CRISTALLO LUX 120 AVORIO (60x120 cm).

# CRISTALLO collection

| PORCELÁNICO · PORCELAIN | RECTIFICADO · RECTIFIED | DESTONIFICADO V2 · DESTONIFIED V2 |

[ESCALA DE LA GRÁFICA 1/2 · GRAPHIC SCALE 1/2]

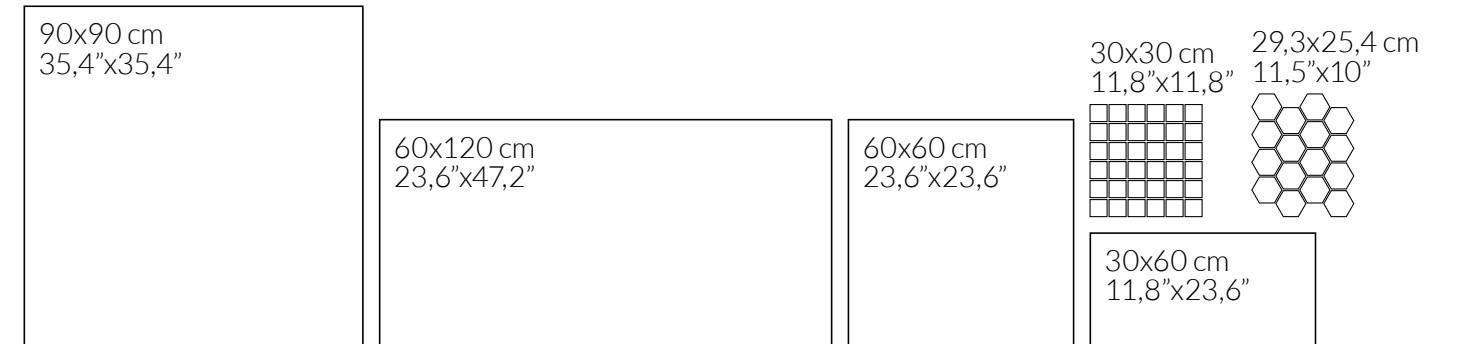

FORMATOS DISPONIBLES AVAILABLE FORMATS	ACABADO NATURAL NATURAL FINISH 	ACABADO LAPADO BRILLO GLOSSY LAPATTO FINISH 
90x90 cm · 35,4"x35,4"	CRISTALLO 9090   B50	---
60x120 cm · 23,6"x47,2"	CRISTALLO 120   B85 ---	CRISTALLO LUX 120   B83 DECORADO 2 HABANA 120   P94
60x60 cm · 23,6"x23,6"	CRISTALLO 60   B35	CRISTALLO LUX 60   B37
30x60 cm · 11,8"x23,6"	CRISTALLO 3060   B35	CRISTALLO LUX 3060   B37
30x30 cm · 11,8"x11,8"	MOSAICO CRISTALLO T5   P70	MOSAICO CRISTALLO LUX T5   P60
29,3x25,4 cm · 11,5"x10"	MOSAICO CRISTALLO HEX   P15	MOSAICO CRISTALLO LUX HEX   P15
TAMAÑO DEL LIENZO: DOS LIENZOS 120x280 cm · GRAPHIC CHART SIZE: TWO GRAPHIC CHARTS 47,2"x110,2"		



[COLORES DISPONIBLES · AVAILABLE COLORS]





wall: DECORADO 2 HABANA 120 NERO-GOLD (60x120 cm), PORTOPETREO R90 SAND (30x90 cm) PORTOPETREO R90 SALT SAND (30x90 cm), DECORADO LAMEO R120 ROVERE (40x120 cm).  
floor: SANTANYI 9090 SAND (90x90 cm).



wall: DECORADO 2 HABANA 120 NERO-SILVER (60x120 cm).

| PIEZAS DECORATIVAS · DECORATIVE PIECES |

DECORADO 2 HABANA 120 | 60x120 cm | P94

Colocación y mantenimiento de baldosas cerámicas con recubrimiento PVD. Página 328.  
Formado por dos piezas. Prestar atención a la continuidad del diseño durante la colocación. Unidad de venta: 1 caja.  
Placement and maintenance of ceramic tiles with PVD coating. Page 329.  
Set of two matching pieces. Please pay attention to design ongoing graphic during tile installation. Sales unit: 1 box.



AVORIO-GOLD

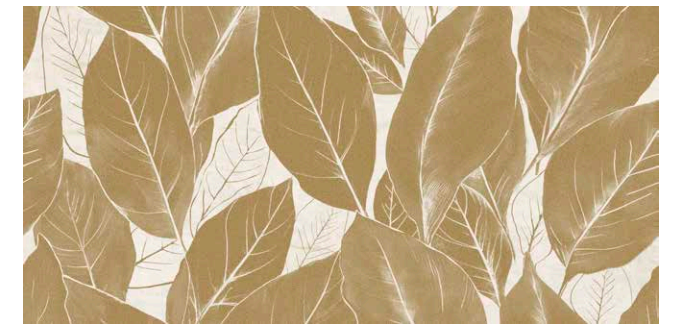

BIANCO-GOLD



NERO-GOLD



GRIGIO-SILVER



NERO-SILVER





wall: CRISTALLO 120 NERO (60x120 cm), COLORS 5x50 TEJA GLOSSY (5x50 cm).  
floor: CRISTALLO 9090 AVORIO (90x90 cm).





wall: DA VINCI LUX 3060 WHITE (30x60 cm), MOSAICO DA VINCI LUX T5 WHITE (30x30 cm).  
floor: DA VINCI LUX 60 WHITE (60x60 cm).

# DA VINCI collection

| PORCELÁNICO · PORCELAIN | RECTIFICADO · RECTIFIED | DESTONIFICADO V2 · DESTONIFIED V2 |

60x120 cm  
23,6"x47,2"



60x60 cm  
23,6"x23,6"

30x60 cm  
11,8"x23,6"

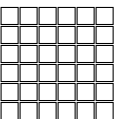
30x30 cm  
11,8"x11,8"



wall and floor: DA VINCI LUX 120 WHITE (60x120 cm).

FORMATOS DISPONIBLES AVAILABLE FORMATS	ACABADO NATURAL NATURAL FINISH	ACABADO LAPADO BRILLO GLOSSY LAPATTO FINISH
		
60x120 cm · 23,6"x47,2"	DA VINCI NAT 120   B85	DA VINCI LUX 120   B83
60x60 cm · 23,6"x23,6"	---	DA VINCI LUX 60   B37
30x60 cm · 11,8"x23,6"	---	DA VINCI LUX 3060   B37
30x30 cm · 11,8"x11,8"	---	MOSAICO DA VINCI LUX T5   P60 
Nº DISEÑOS POR FORMATO · Nº DESIGNS BY FORMAT:   60x120: 6   60x60: 12   30x60: 24		



**E**  
WHITE

COLORES DISPONIBLES · AVAILABLE COLORS





wall: DUBAI 120 ICE Y GREY (60x120 cm),  
floor: DUBAI 120 GREY (60x120 cm).



wall: DUBAI LUX 120 GRAPHITE (60x120 cm),  
floor: DUBAI LUX 120 ICE (60x120 cm).

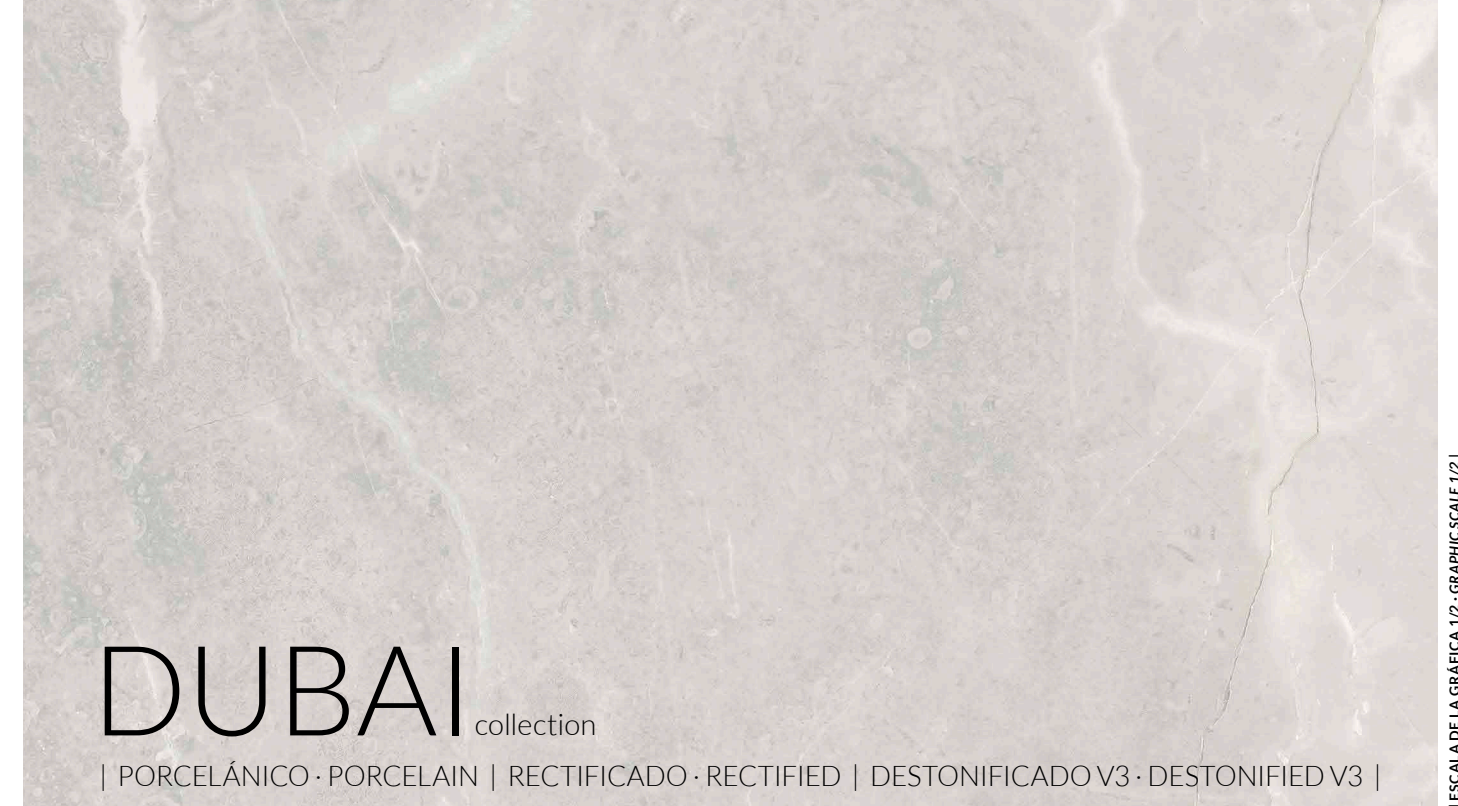

# DUBAI

collection

| PORCELÁNICO · PORCELAIN | RECTIFICADO · RECTIFIED | DESTONIFICADO V3 · DESTONIFIED V3 |

| ESCALA DE LA GRÁFICA 1:2 · GRAPHIC SCALE 1/2 |

60x120 cm 23,6"x47,2"	60x60 cm 23,6"x23,6"	30x30 cm 11,8"x11,8"	24,7x22,6 cm 9,7"x18,9"

FORMATOS DISPONIBLES AVAILABLE FORMATS	ACABADO NATURAL NATURAL FINISH	ACABADO LAPADO BRILLO GLOSSY LAPATTO FINISH
60x120 cm · 23,6"x47,2"	DUBAI 120   B85 	DUBAI LUX 120   B83 
60x60 cm · 23,6"x23,6"	DUBAI 60   B35	DUBAI LUX 60   B37
30x30 cm · 11,8"x11,8"	MOSAICO DUBAI T5   P70 	MOSAICO DUBAI LUX T5   P60 
24,7x22,6 cm · 9,7"x8,9"	MOSAICO DUBAI DIAMOND   P12 	MOSAICO DUBAI LUX DIAMOND   P12 
TAMAÑO DEL LIENZO: DOS LIENZOS 132x264 cm · GRAPHIC CHART SIZE: TWO GRAPHIC CHARTS 52"x103,9"		

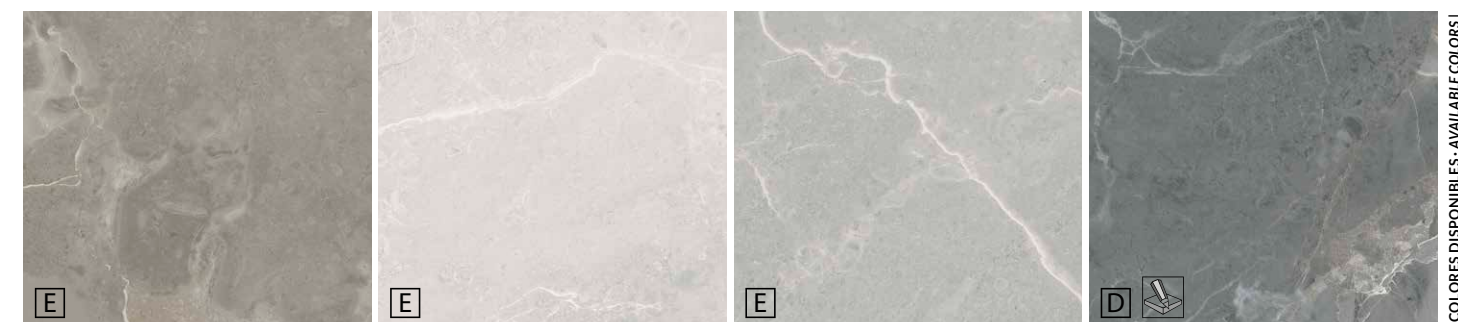

TAUPE      ICE      GREY      GRAPHITE

| COLORES DISPONIBLES · AVAILABLE COLORS |





wall: FONTANA LUX 120 ICE (60x120 cm).  
floor: FONTANA LUX 120 VISON (60x120 cm).

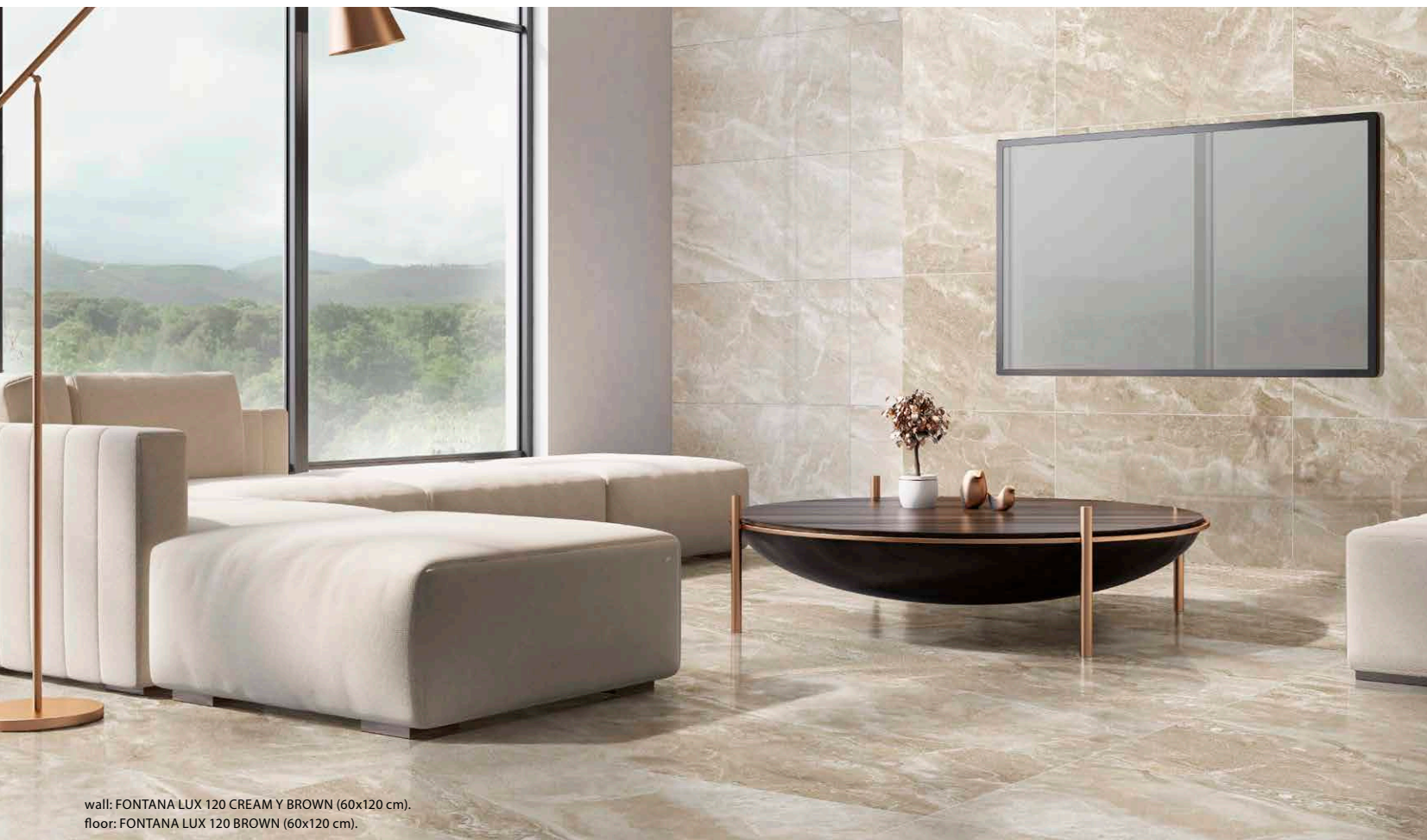

wall: FONTANA LUX 120 CREAM Y BROWN (60x120 cm).  
floor: FONTANA LUX 120 BROWN (60x120 cm).



# FONTANA<sub>collection</sub>

| PORCELÁNICO · PORCELAIN | RECTIFICADO · RECTIFIED | DESTONIFICADO V3 · DESTONIFIED V3 |

| ESCALA DE LA GRÁFICA 1/2 · GRAPHIC SCALE 1/2 |

60x120 cm 23,6"x47,2"	60x60 cm 23,6"x23,6"
--------------------------	-------------------------

FORMATOS DISPONIBLES AVAILABLE FORMATS	ACABADO LAPADO BRILLO GLOSSY LAPATTO FINISH 
60x120 cm · 23,6"x47,2"	<b>FONTANA LUX 120   B83</b>
60x60 cm · 23,6"x23,6"	<b>FONTANA LUX 60   B37</b>
TAMAÑO DEL LIENZO: 175x355 cm · GRAPHIC CHART SIZE: 68,8"x139,7"	

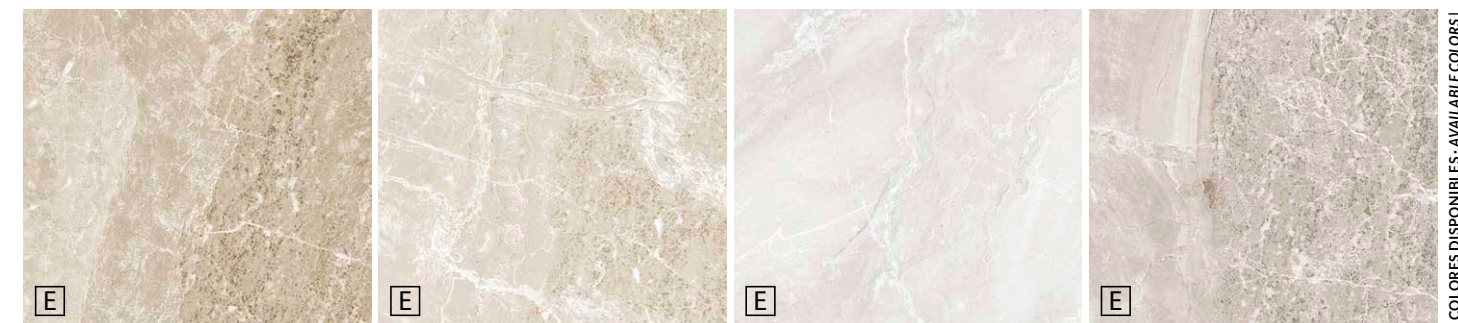

**B** BROWN

**C** CREAM

**I** ICE

**V** VISON

| COLORES DISPONIBLES · AVAILABLE COLORS |





floor: JASPER LUX 60 GREY (60x60 cm).



floor: JASPER LUX 60 BEIGE (60x60 cm).



# JASPER<sub>collection</sub>

| PORCELÁNICO · PORCELAIN | RECTIFICADO · RECTIFIED | DESTONIFICADO V3 · DESTONIFIED V3 |

[ESCALA DE LA GRÁFICA 1/2 · GRAPHIC SCALE 1/2]

60x60 cm  
23,6"x23,6"

<p>FORMATOS DISPONIBLES AVAILABLE FORMATS</p>	<p>ACABADO LAPADO BRILLO · GLOSSY LAPATTO FINISH</p>
<p>60x60 cm · 23,6"x23,6"</p>	<p>JASPER LUX 60   B37</p>

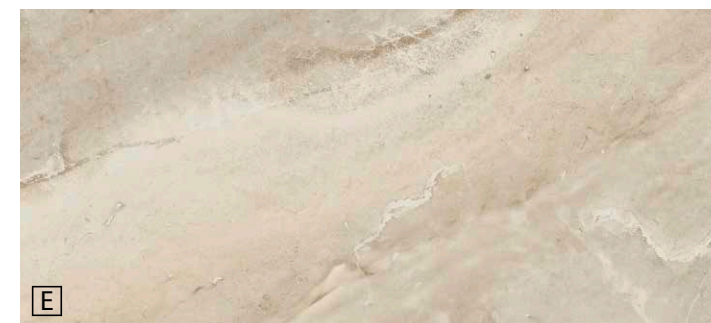

**E**  
BEIGE



**E**  
GREY

[COLORES DISPONIBLES · AVAILABLE COLORS]





wall: DECORADO PALM R90 WHITE MATT (30x90 cm).  
 floor: MACCHIA VECCHIA LUX 120 SILVER (60x120 cm).



# MACCHIA VECCHIA collection

| PORCELÁNICO · PORCELAIN | RECTIFICADO · RECTIFIED | DESTONIFICADO V2 · DESTONIFIED V2 |

| ESCALA DE LA GRÁFICA 1/2 - GRAPHIC SCALE 1/2 |

60x120 cm 23,6"x47,2"	60x60 cm 23,6"x23,6"	30x60 cm 11,8"x23,6"	30x30 cm 11,8"x11,8"	27,4x29,8 cm 10,8"x11,7"

FORMATOS DISPONIBLES AVAILABLE FORMATS	ACABADO NATURAL · NATURAL FINISH 	ACABADO LAPADO BRILLO · GLOSSY LAPATTO FINISH 
60x120 cm · 23,6"x47,2"	MACCHIA VECCHIA NAT 120   B85	MACCHIA VECCHIA LUX 120   B83
60x60 cm · 23,6"x23,6"	MACCHIA VECCHIA NAT 60   B35 (gold)	MACCHIA VECCHIA LUX 60   B37 (gold)
30x60 cm · 11,8"x23,6"	MACCHIA VECCHIA NAT 3060   B35 (gold)	MACCHIA VECCHIA LUX 3060   B37 (gold)
30x30 cm · 11,8"x11,8"	MOSAICO MACCHIA VECCHIA NAT T5   P70 	MOSAICO MACCHIA VECCHIA LUX T5   P60 
27,4x29,8 cm · 10,8"x11,7"	MOSAICO MACCHIA VECCHIA NAT PICKET   P15 	MOSAICO MACCHIA VECCHIA LUX PICKET   P15 
TAMAÑO DEL LIENZO: 100x300 cm · GRAPHIC CHART SIZE: 39,4"x118,1"		

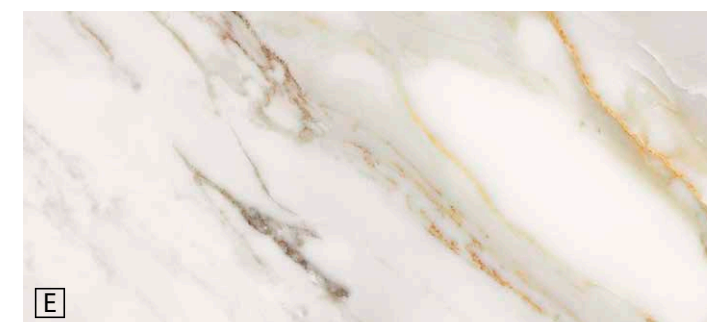

**E**  
GOLD



**E**  
SILVER

| COLORES DISPONIBLES · AVAILABLE COLORS |





wall: MOSAICO MACCHIA VECCHIA NAT PICKET GOLD (27,4x29,8 cm), MACCHIA VECCHIA R90 GOLD MATT (30x90 cm).  
 floor: MACCHIA VECCHIA NAT 60 GOLD (60x60 cm).

# MACCHIA VECCHIA<sup>collection</sup>

| PASTA BLANCA · WHITE BODY | RECTIFICADO · RECTIFIED | DESTONIFICADO V2 · DESTONIFIED V2 |

## | PIEZAS DECORATIVAS · DECORATIVE PIECES |

**DECORADO PALM R90 WHITE MATT | 30x90 cm | B44**  
 Cinco piezas diferentes. Unidad de venta: 1 caja. - Five different pieces. Sales unit: 1 box.



Decoración complementaria recomendada: - Recommended complementary decoration pieces:  
**LISTELO 90 FRAME | 9,3x90 cm | P25**  
 Tres piezas diferentes. Unidad de venta: 1 caja. - Three different pieces. Sales unit: 1 box.



COBRE



ACERO

30x90 cm  
 11,8"x35,4"

FORMATOS DISPONIBLES  
 AVAILABLE FORMATS

ACABADO MATE · MATT FINISH



30x90 cm · 11,8"x35,4"

MACCHIA VECCHIA R90 MATT | B42

DECORADO PALM R90 WHITE MATT | B44



TAMAÑO DEL LIENZO: 100x300 cm · GRAPHIC CHART SIZE: 39,4"x118,1"

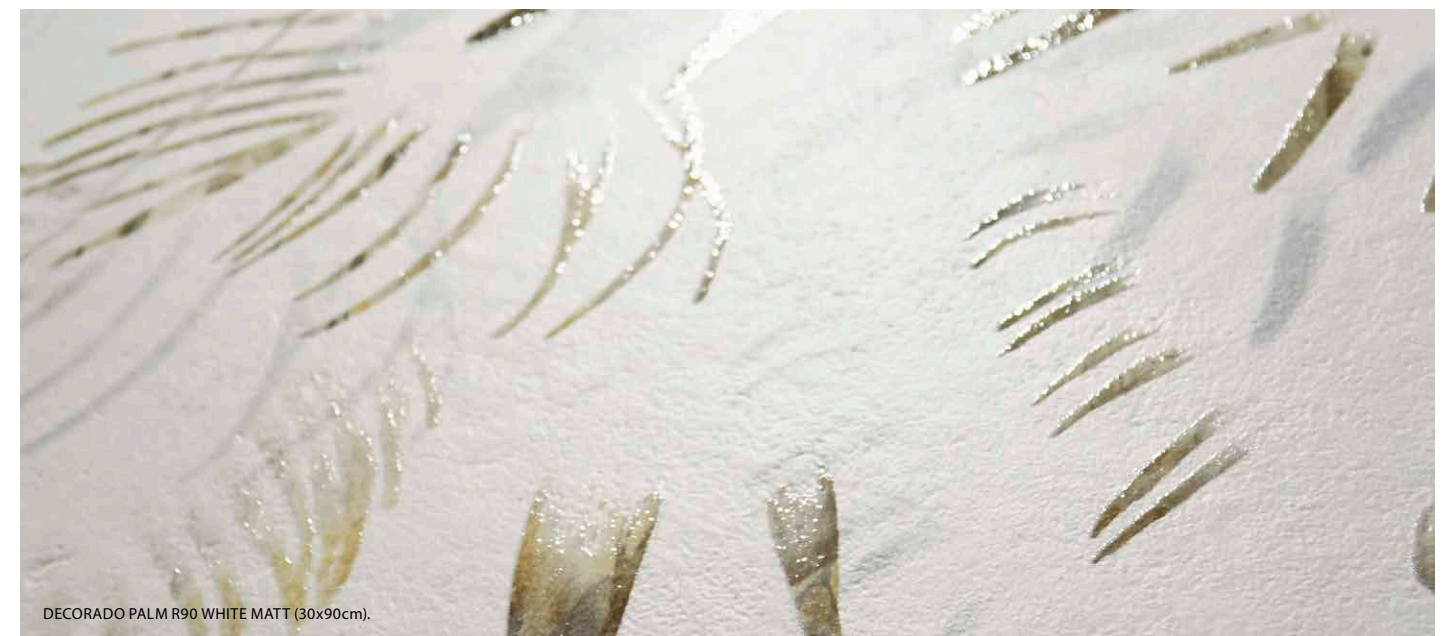

DECORADO PALM R90 WHITE MATT (30x90cm).



GOLD



SILVER

COLORES DISPONIBLES · AVAILABLE COLORS





wall: INVISIBLE LUX 120 WHITE (60x120cm).  
floor: BOMBAY LUX 60 (60x60cm).

# MARBLEFULL BOMBAY<sup>collection</sup>

| PORCELÁNICO · PORCELAIN | RECTIFICADO · RECTIFIED | DESTONIFICADO V3 · DESTONIFIED V3 |

60x120 cm  
23,6"x47,2"

18,5x120 cm  
7,3"x47,2"

60x60 cm  
23,6"x23,6"

FORMATOS DISPONIBLES AVAILABLE FORMATS	ACABADO LAPADO BRILLO · GLOSSY LAPATTO FINISH
60x120 cm · 23,6"x47,2"	BOMBAY LUX 120   B83
18,5x120 cm · 7,3"x47,2"	SLATS BOMBAY LUX 120   P90
60x60 cm · 23,6"x23,6"	BOMBAY LUX 60   B37
TAMAÑO DEL LIENZO: 132x374 cm · GRAPHIC CHART SIZE: 52"x147,2"	

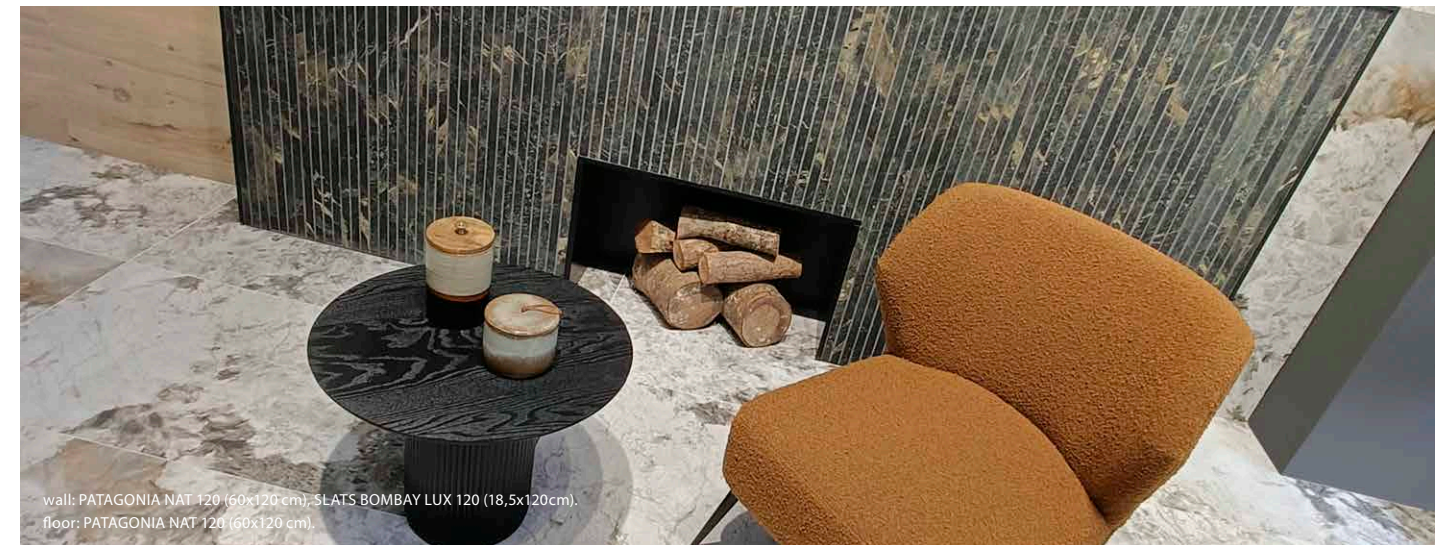

wall: PATAGONIA NAT 120 (60x120 cm); SLATS BOMBAY LUX 120 (18,5x120 cm).  
floor: PATAGONIA NAT 120 (60x120 cm).

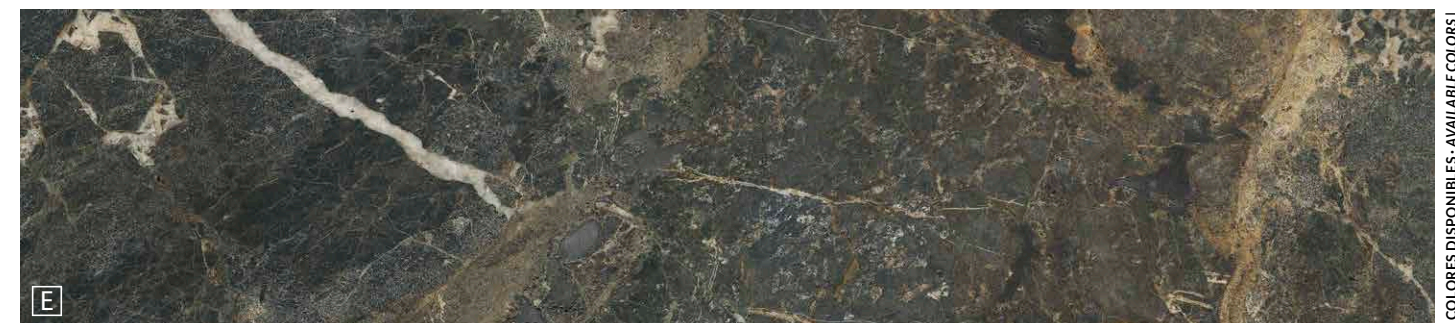

E

COLORES DISPONIBLES · AVAILABLE COLORS





wall: BOMBAY LUX 120 (60x120cm), SLATS BOMBAY LUX 120 (18,5x120 cm), INVISIBLE NAT 120 WHITE (60x120cm), SLATS BARRICA 120 NUEZ (18,5x120 cm).  
 floor: BOMBAY LUX 120 (60x120cm).



wall: BOMBAY LUX 120 (60x120cm), SLATS BARRICA 120 NUEZ (18,5x120 cm).  
 floor: BOMBAY LUX 120 (60x120cm).





wall: INVISIBLE NAT 120 WHITE (60x120cm), DECORADO INVICTUS NAT 120 WHITE (60x120 cm).  
 floor: INVISIBLE NAT 120 WHITE (60x120cm).



# MARBLEFULL INVISIBLE collection

| PORCELÁNICO · PORCELAIN | RECTIFICADO · RECTIFIED | DESTONIFICADO V3 · DESTONIFIED V3 |

ESCALA DE LA GRÁFICA 1/2 - GRAPHIC SCALE 1/21

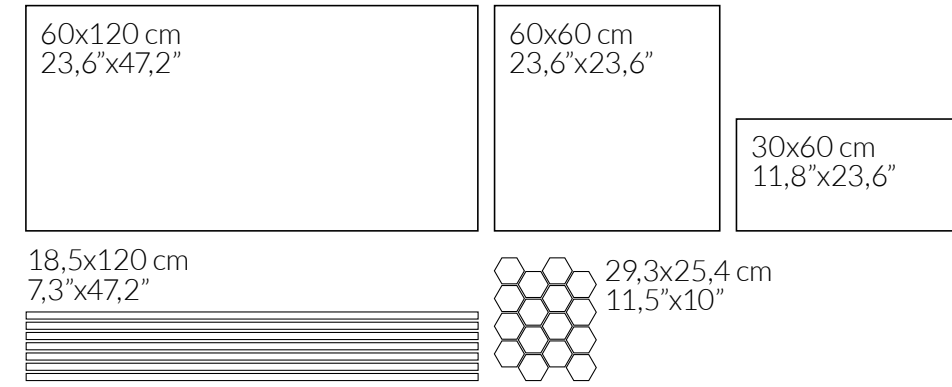

FORMATOS DISPONIBLES AVAILABLE FORMATS	ACABADO NATURAL · NATURAL FINISH	ACABADO LAPADO BRILLO · GLOSSY LAPATTO FINISH
60x120 cm · 23,6"x47,2"	INVISIBLE NAT 120   B85 DECORADO INVICTUS NAT 120   B70	INVISIBLE LUX 120   B83 ---
60x60 cm · 23,6"x23,6"	INVISIBLE NAT 60   B35	INVISIBLE LUX 60   B37
30x60 cm · 11,8"x23,6"	INVISIBLE NAT 3060   B35	INVISIBLE LUX 3060   B37
18,5x120 cm · 7,3"x47,2"	SLATS INVISIBLE NAT 120   P90	SLATS INVISIBLE LUX 120   P90
29,3x25,4 cm · 11,5"x10"	MOSAICO INVISIBLE NAT HEX   P15	MOSAICO INVISIBLE LUX HEX   P15
Nº DISEÑOS POR FORMATO · Nº DESIGNS BY FORMAT:   60x120: 8   60x60: 11   30x60: 22		

| PIEZAS DECORATIVAS · DECORATIVE PIECES |

DECORADO INVICTUS NAT 120 | 60x120 cm | B70

Tres piezas diferentes. Unidad de venta: 1 caja. - Three different pieces. Sales unit: 1 box.



WHITE

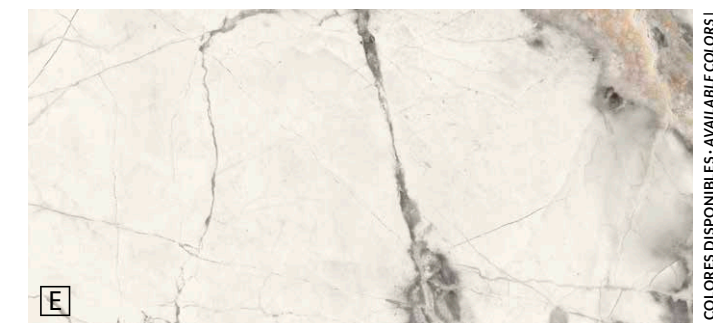

WHITE

COLORES DISPONIBLES · AVAILABLE COLORS





wall: INVISIBLE NAT 120 WHITE (60x120cm), SLATS LEGNO 120 ROVERE (18,5x120cm).  
floor: INVISIBLE NAT 120 WHITE (60x120cm).





wall and floor: PATAGONIA NAT 120 (60x120cm).

# MARBLEFULL PATAGONIA collection

| PORCELÁNICO · PORCELAIN | RECTIFICADO · RECTIFIED | DESTONIFICADO V3 · DESTONIFIED V3 |

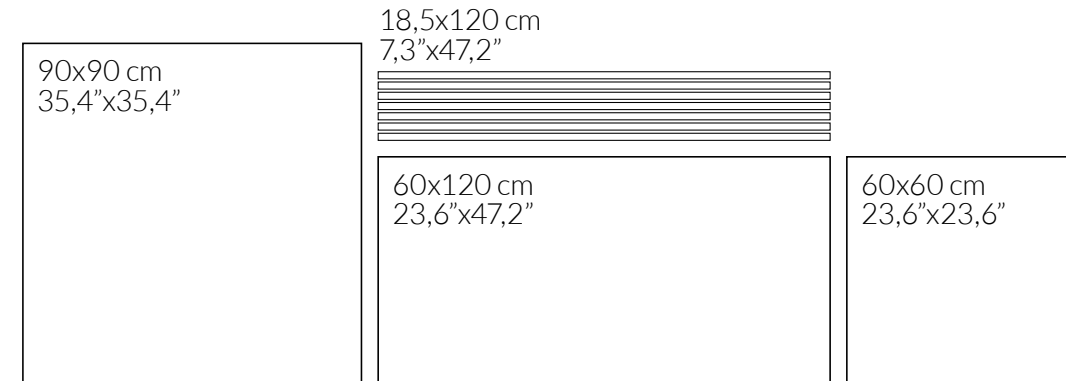

FORMATOS DISPONIBLES AVAILABLE FORMATS	ACABADO NATURAL · NATURAL FINISH	ACABADO LAPADO BRILLO · GLOSSY LAPATTO FINISH
90x90 cm · 35,4"x35,4"	PATAGONIA NAT 9090   B50	---
60x120 cm · 23,6"x47,2"	PATAGONIA NAT 120   B85	PATAGONIA LUX 120   B83
18,5x120 cm · 7,3"x47,2"	SLATS PATAGONIA NAT 120   P90	SLATS PATAGONIA LUX 120   P90
60x60 cm · 23,6"x23,6"	PATAGONIA NAT 60   B35	PATAGONIA LUX 60   B37
Nº DISEÑOS POR FORMATO · Nº DESIGNS BY FORMAT:   90x90: 6   60x120: 6   60x60: 12		



PATAGONIA LUX 120 (60x120cm).



E

COLORES DISPONIBLES · AVAILABLE COLORS





wall: PATAGONIA LUX 120 (60x120cm), BOMBAY LUX 120 (60x120cm), SLATS PATAGONIA LUX 120 (18,5x120 cm), SLATS LEGNO 120 ROVERE (18,5x120 cm).  
 floor: PATAGONIA LUX 120 (60x120cm).

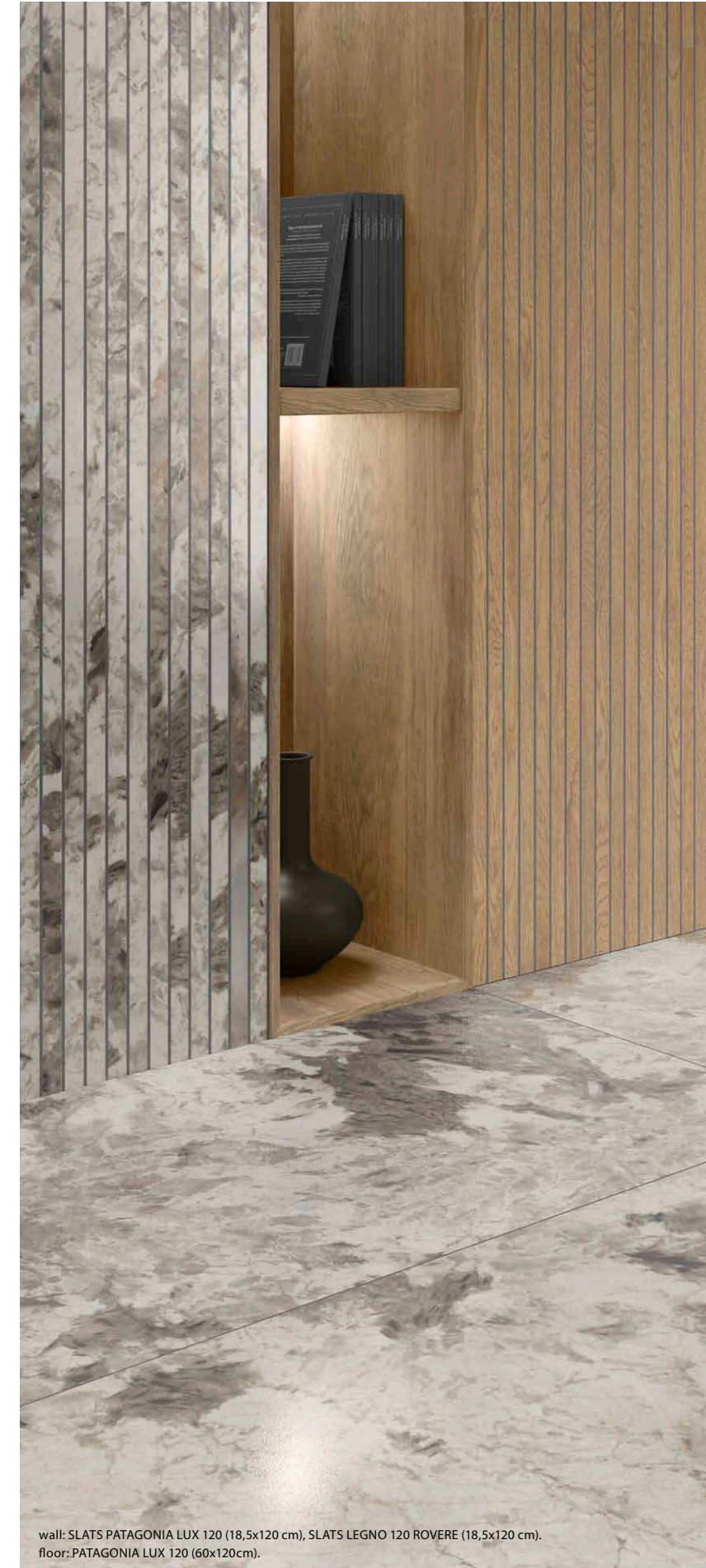

wall: SLATS PATAGONIA LUX 120 (18,5x120 cm), SLATS LEGNO 120 ROVERE (18,5x120 cm).  
 floor: PATAGONIA LUX 120 (60x120cm).





floor: NAGOYA LUX 120 GREY (60x120 cm).



wall: NAGOYA 3060 GREY (30x60 cm), LEGNO 20 ROVERE (19,4x120 cm).  
floor: NAGOYA 60 GRAPHITE (60x60 cm).



# NAGOYA

collection

| PORCELÁNICO · PORCELAIN | RECTIFICADO · RECTIFIED | DESTONIFICADO V3 · DESTONIFIED V3 |

ESCALA DE LA GRÁFICA 1/2 · GRAPHIC SCALE 1/2 |

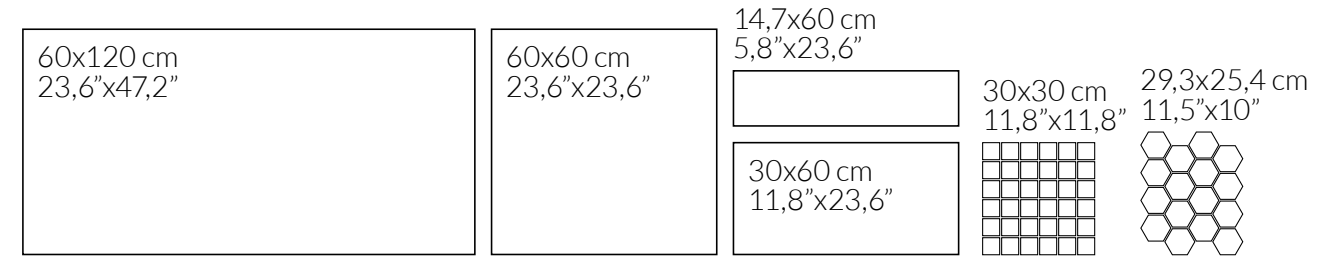

FORMATOS DISPONIBLES AVAILABLE FORMATS	ACABADO NATURAL · NATURAL FINISH 	ACABADO LAPADO BRILLO · GLOSSY LAPATTO FINISH 
60x120 cm · 23,6" x 47,2"	NAGOYA 120   B85	NAGOYA LUX 120   B83
60x60 cm · 23,6" x 23,6"	NAGOYA 60   B35	NAGOYA LUX 60   B37
30x60 cm · 11,8" x 23,6"	NAGOYA 3060   B35	NAGOYA LUX 3060   B37
14,7x60 cm · 5,8" x 23,6"	NAGOYA 15x60   B16	NAGOYA LUX 15x60   B17
30x30 cm · 11,8" x 11,8"	MOSAICO NAGOYA T5   P70	MOSAICO NAGOYA LUX T5   P60
29,3x25,4 cm · 11,5" x 10"	MOSAICO NAGOYA HEX   P15	MOSAICO NAGOYA LUX HEX   P15

TAMAÑO DEL LIENZO: 160x360 cm · GRAPHIC CHART SIZE: 63" x 141,7"

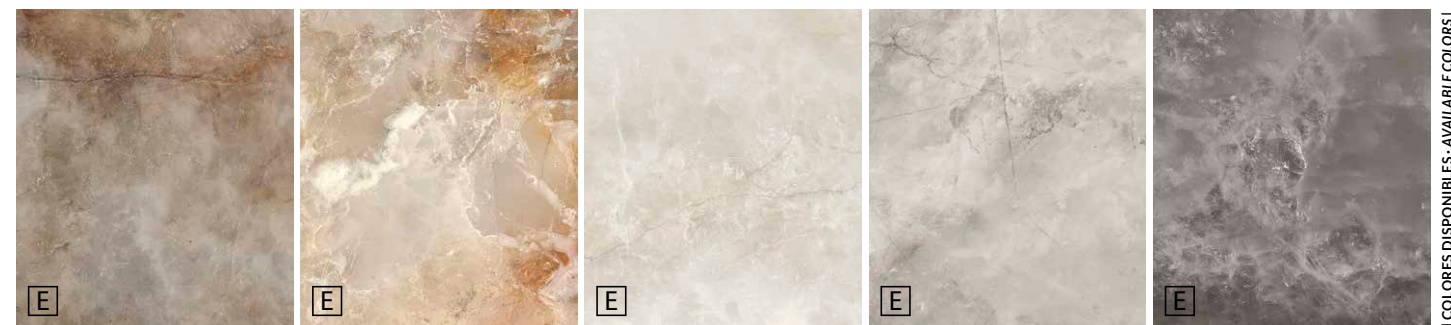

GREIGE

CRYSTAL

MARFIL

GREY

GRAPHITE

COLORES DISPONIBLES · AVAILABLE COLORS |



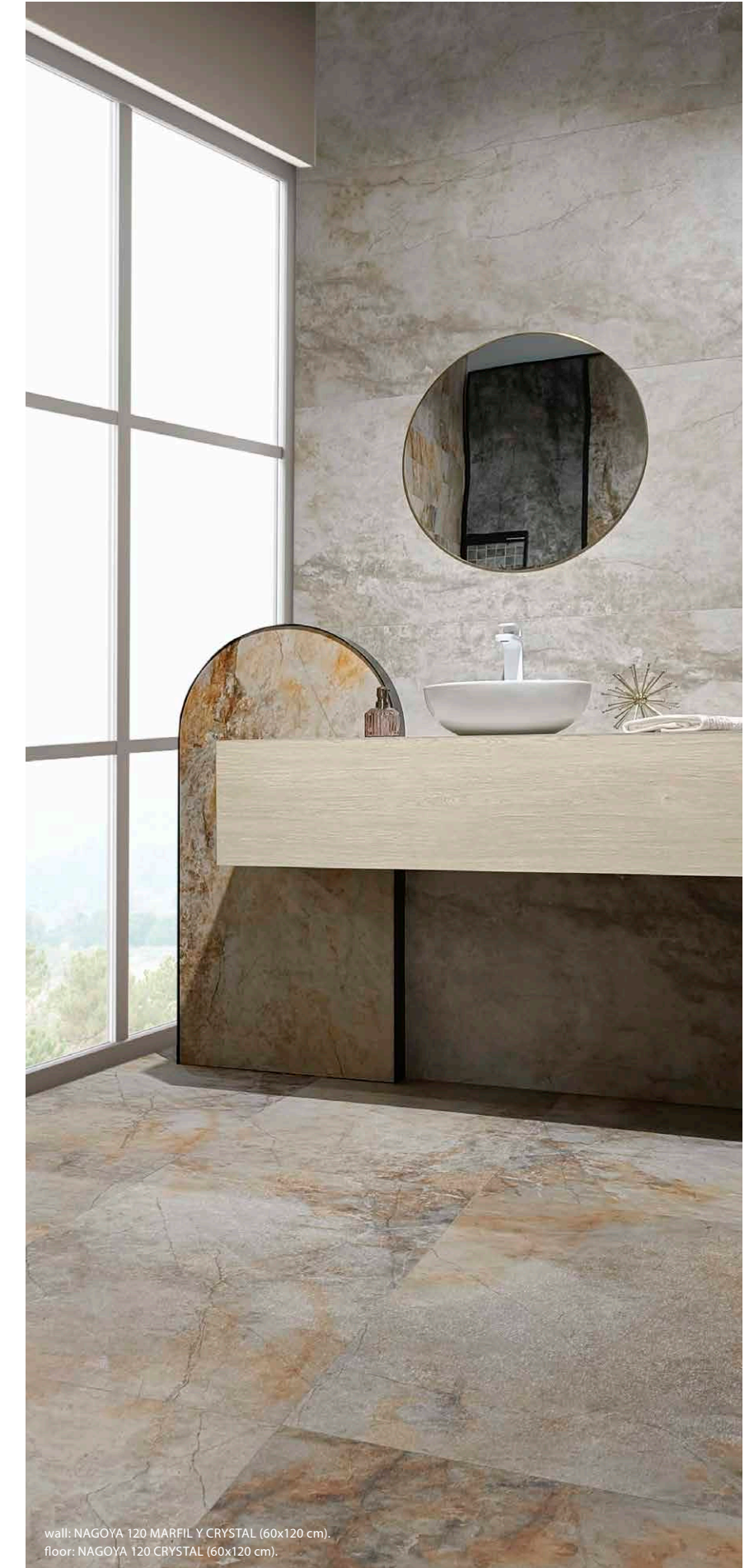





wall: NAGOYA LUX 3060 MARFIL Y GREIGE (30x60 cm), MOSAICO NAGOYA LUX HEX GREIGE (27,5x29,3 cm).  
 floor: NAGOYA LUX 60 MARFIL (60x60 cm).



wall: NAGOYA LUX 120 CRYSTAL (60x120 cm), MOSAICO NAGOYA LUX T5 CRYSTAL (30x30 cm), LEGNO 20 y 30 NOCE (19,4x120 y 30x120 cm).  
 floor: NAGOYA LUX 120 CRYSTAL (60x120 cm).





wall and floor: ONYX LUX 120 IVORY (60x120 cm), BARRICA 30 MIEL (30x120 cm).



# ONYX<sub>collection</sub>

| PORCELÁNICO · PORCELAIN | RECTIFICADO · RECTIFIED | DESTONIFICADO V3 · DESTONIFIED V3 |

ESCALA DE LA GRÁFICA 1/2 - GRAPHIC SCALE 1/2 |

60x120 cm 23,6"x47,2"	60x60 cm 23,6"x23,6"	30x60 cm 11,8"x23,6"	30x30 cm 11,8"x11,8"	21,6x28 cm 8,5"x11"
--------------------------	-------------------------	-------------------------	-------------------------	------------------------



wall: ONYX LUX 120 DARK GREY (60x120 cm), MOSAICO ONYX LUX V DARK GREY (21,6x28 cm).  
floor: ONYX LUX 120 DARK GREY (60x120 cm).

FORMATOS DISPONIBLES AVAILABLE FORMATS	ACABADO LAPADO BRILLO · GLOSSY LAPATTO FINISH
60x120 cm · 23,6"x47,2"	ONYX LUX 120   B83
60x60 cm · 23,6"x23,6"	ONYX LUX 60   B37
30x60 cm · 11,8"x23,6"	ONYX LUX 3060   B37
30x30 cm · 11,8"x11,8"	MOSAICO ONYX LUX T5   P60
21,6x28 cm · 8,5"x11"	MOSAICO ONYX LUX V   P12

TAMAÑO DEL LIENZO: DOS LIENZOS 120x240 cm · GRAPHIC CHART SIZE: TWO GRAPHIC CHARTS 47,2"x94,5"



LIGHT GREEN    IVORY    LIGHT GREY    DARK GREY    LIGHT BLUE

COLORES DISPONIBLES · AVAILABLE COLORS |





wall: ONYX R90 IVORY (30x90 cm), ONYX R90 LOT IVORY (30x90 cm), LISTELO 90 FRAME COBRE (9,3x90 cm).  
 floor: ONYX LUX 60 IVORY (60x60 cm).

| PIEZAS DECORATIVAS · DECORATIVE PIECES |

ONYX R90 LOT | 30x90 cm | B43



LIGHT GREEN



IVORY



LIGHT GREY



DARK GREY



LIGHT BLUE

# ONYX collection

| PASTA BLANCA · WHITE BODY |  
 | RECTIFICADO · RECTIFIED |  
 | DESTONIFICADO V3 · DESTONIFIED V3 |

30x90 cm  
 11,8"x35,4"

FORMATOS DISPONIBLES AVAILABLE FORMATS	ACABADO MATE · MATT FINISH 
30x90 cm · 11,8"x35,4"	ONYX R90   B42 
	ONYX R90 LOT   B43 
TAMAÑO DEL LIENZO: 2 LIENZOS 120x240 cm · GRAPHIC CHART SIZE: 2 GRAPHIC CHARTS 47,2"x95,4"	

Decoración complementaria recomendada: - Recommended complementary decoration pieces:  
 LISTELO 90 FRAME | 9,3x90 cm | P25  
 Tres piezas diferentes. Unidad de venta: 1 caja. - Three different pieces. Sales unit: 1 box.



wall: ONYX R90 LIGHT BLUE (30x90 cm), COLORS 5x50 DARK GREY MATT (5x50 cm).  
 floor: ONYX LUX 60 LIGHT BLUE (60x60 cm).

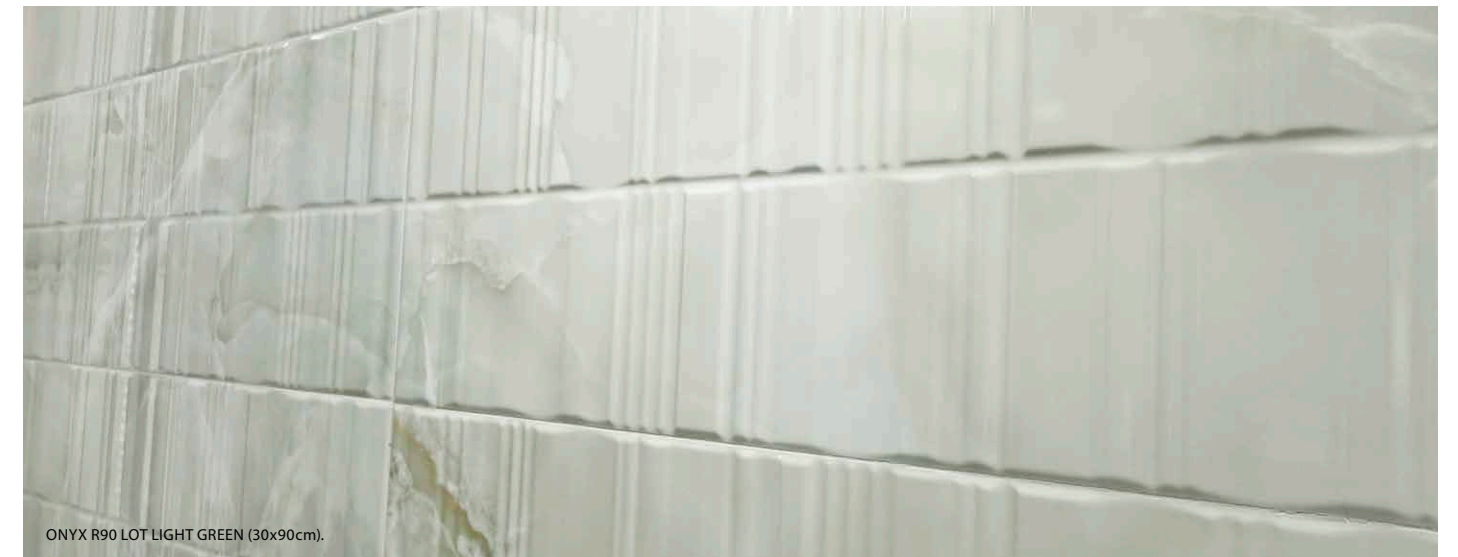

ONYX R90 LOT LIGHT GREEN (30x90cm).



LIGHT GREEN

IVORY

LIGHT GREY

DARK GREY

LIGHT BLUE

COLORES DISPONIBLES · AVAILABLE COLORS





wall: DECORADO SPINE R90 NUDE (30x90 cm).  
floor: PARADOX 9090 GOLD (90x90 cm).







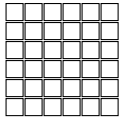
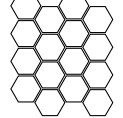

# PARADOX collection

| PORCELÁNICO · PORCELAIN | RECTIFICADO · RECTIFIED | DESTONIFICADO V3 · DESTONIFIED V3 |

ESCALA DE LA GRÁFICA 1/2 · GRAPHIC SCALE 1/2 |

90x90 cm 35,4"x35,4"	60x120 cm 23,6"x47,2"	60x60 cm 23,6"x23,6"	30x30 cm 11,8"x11,8"	29,3x25,4 cm 11,5"x10"
				
			30x60 cm 11,8"x23,6"	

FORMATOS DISPONIBLES AVAILABLE FORMATS	ACABADO NATURAL · NATURAL FINISH 	ACABADO LAPADO BRILLO · GLOSSY LAPATTO FINISH 
90x90 cm · 35,4"x35,4"	PARADOX 9090   B50	---
60x120 cm · 23,6"x47,2"	PARADOX 120   B85	PARADOX LUX 120   B83
60x60 cm · 23,6"x23,6"	PARADOX 60   B35	PARADOX LUX 60   B37
30x60 cm · 11,8"x23,6"	PARADOX 3060   B35	PARADOX LUX 3060   B37
30x30 cm · 11,8"x11,8"	MOSAICO PARADOX T5   P70 	MOSAICO PARADOX LUX T5   P60 
29,3x25,4 cm · 11,5"x10"	MOSAICO PARADOX HEX   P15 	MOSAICO PARADOX LUX HEX   P15 
TAMAÑO DEL LIENZO: DOS LIENZOS 120x280 cm · GRAPHIC CHART SIZE: TWO GRAPHIC CHARTS 47,2"x110,2"		



GOLD

WHITE

NATURE

COLORES DISPONIBLES · AVAILABLE COLORS |





wall: COLORS 5x25 GREEN GLOSSY (5x25 cm), DECORADO LAMEO R120 ROVERE (40x120 cm), KALEIDOSCOPE 120 CREAM (60x120 cm).  
 floor: PARADOX 120 NATURE (60x120 cm).





wall: PARADOX 120 GOLD (60x120 cm), NEBRASKA 30 NOGAL (30x120 cm).  
floor: PARADOX 120 GOLD (60x120 cm).

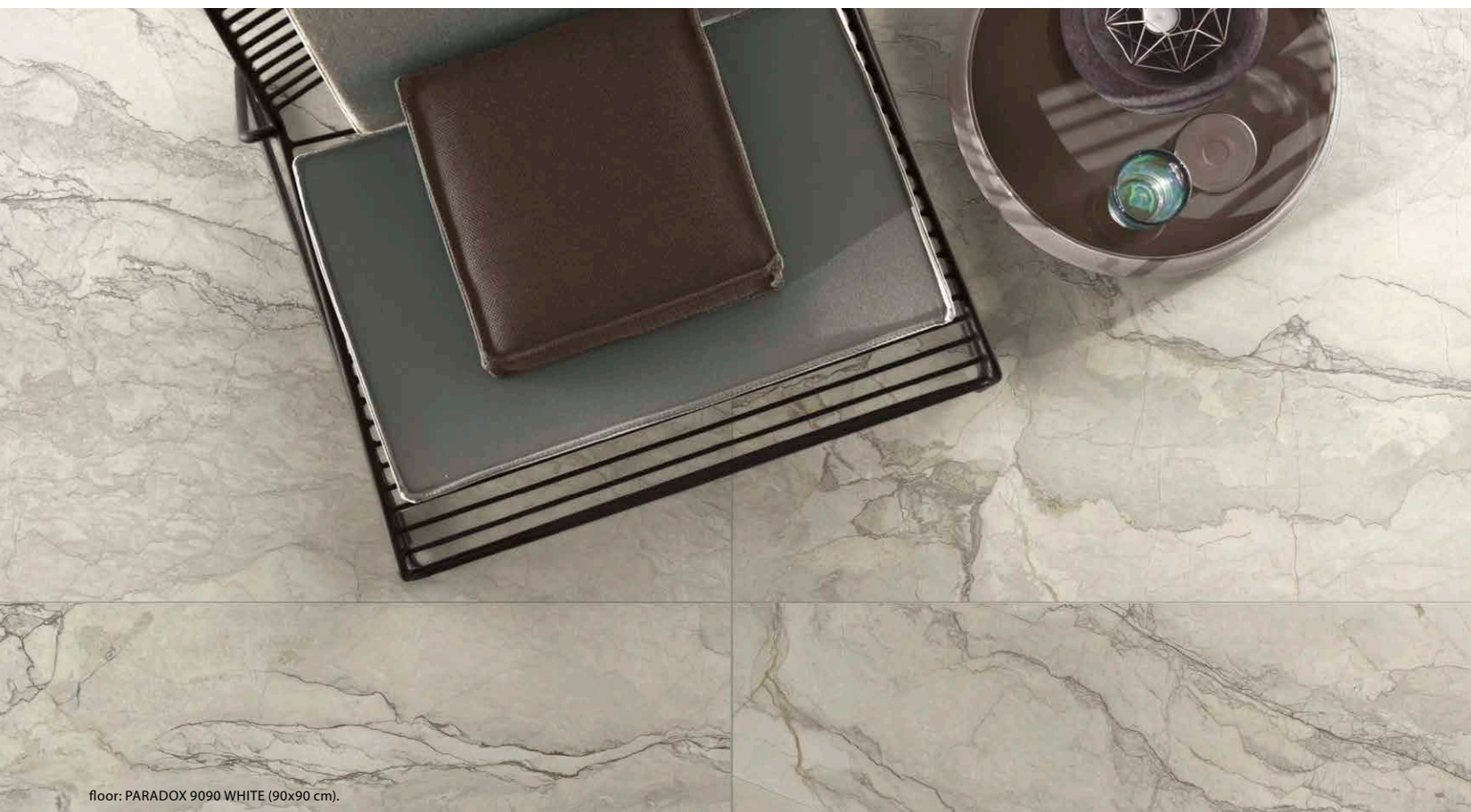

floor: PARADOX 9090 WHITE (90x90 cm).



wall and floor: PARADOX LUX 120 GOLD (60x120 cm).





wall: PASSION LUX 3060 CHAMPAGNE (30x60 cm).



wall: PASSION LUX 120 GREY (60x120 cm).  
floor: PASSION LUX 120 ICE (60x120 cm).



# PASSION collection

| PORCELÁNICO · PORCELAIN | RECTIFICADO · RECTIFIED | DESTONIFICADO V3 · DESTONIFIED V3 |

ESCALA DE LA GRÁFICA 1/2 - GRAPHIC SCALE 1/2!

60x120 cm  
23,6"x47,2"

60x60 cm  
23,6"x23,6"

30x30 cm  
11,8"x11,8"

30x60 cm  
11,8"x23,6"

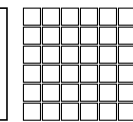

FORMATOS DISPONIBLES AVAILABLE FORMATS	ACABADO LAPADO BRILLO · GLOSSY LAPATTO FINISH
60x120 cm · 23,6"x47,2"	
60x60 cm · 23,6"x23,6"	PASSION LUX 120   B83
30x60 cm · 11,8"x23,6"	PASSION LUX 60   B37
30x30 cm · 11,8"x11,8"	PASSION LUX 3060   B37
30x30 cm · 11,8"x11,8"	MOSAICO PASSION LUX T5   P60
Nº DISEÑOS POR FORMATO · Nº DESIGNS BY FORMAT:   60x120: 8   60x60: 16   30x60: 32	



TAUPE



CHAMPAGNE



ICE

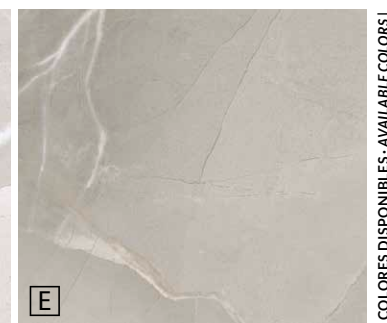

GREY

COLORES DISPONIBLES · AVAILABLE COLORS!





wall: PERLA VENATA LUX 120 CREMA (60x120 cm), DECORADO RUSTIC 15x15 CLAY (15x15 cm).  
floor: PERLA VENATA LUX 120 CREMA (60x120 cm).



# PERLA VENATA collection

| PORCELÁNICO · PORCELAIN | RECTIFICADO · RECTIFIED | DESTONIFICADO V2 · DESTONIFIED V2 |

ESCALA DE LA GRÁFICA 1/2 · GRAPHIC SCALE 1/2 |

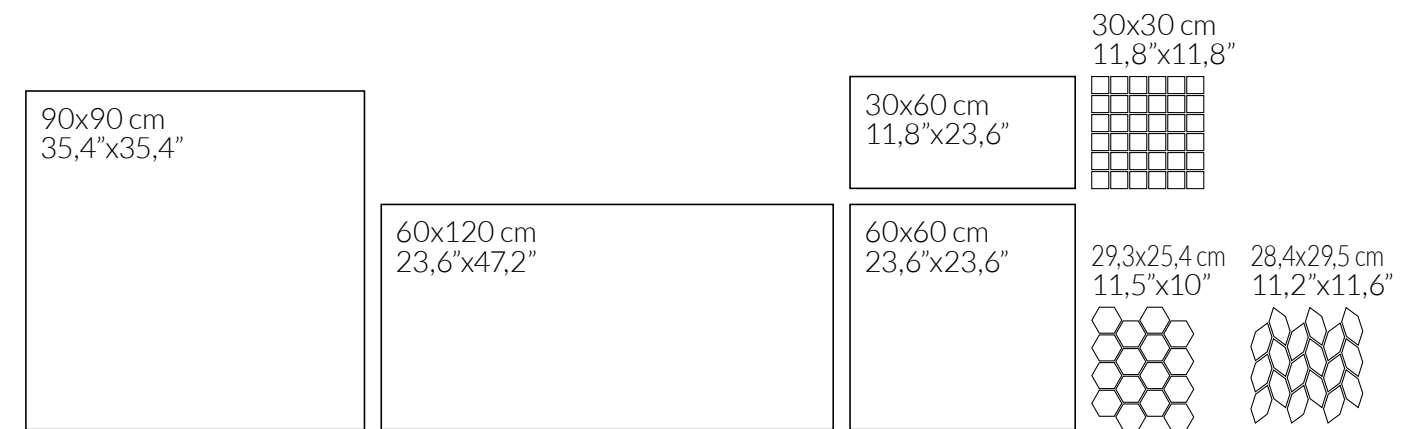

wall: PERLA VENATA LUX 120 BLANCO Y NEGRO (60x120 cm), SLATS LEGNO 120 ROVERE (18.5x120 cm).  
floor: PERLA VENATA LUX 120 NEGRO (60x120 cm).

FORMATOS DISPONIBLES AVAILABLE FORMATS	ACABADO NATURAL · NATURAL FINISH 	ACABADO LAPADO BRILLO · GLOSSY LAPATTO FINISH 
90x90 cm · 35,4"x35,4"	PERLA VENATA 9090   B50	---
60x120 cm · 23,6"x47,2"	PERLA VENATA 120   B85	PERLA VENATA LUX 120   B83
	---	DECORADO 2 VICTORY 120   P94 
60x60 cm · 23,6"x23,6"	PERLA VENATA 60   B35	PERLA VENATA LUX 60   B37
30x60 cm · 11,8"x23,6"	PERLA VENATA 3060   B35	PERLA VENATA LUX 3060   B37
30x30 cm · 11,8"x11,8"	MOSAICO PERLA VENATA T5   P70	MOSAICO PERLA VENATA LUX T5   P60
28,4x29,5 cm · 11,2"x11,6"	MOSAICO PERLA VENATA LEAF   P15	MOSAICO PERLA VENATA LUX LEAF   P15
29,3x25,4 cm · 11,5"x10"	MOSAICO PERLA VENATA HEX   P15	MOSAICO PERLA VENATA LUX HEX   P15
TAMAÑO DEL LIENZO: 195x345 cm · GRAPHIC CHART SIZE: 76,8"x135,8"		



CREMA

BLANCO

GRIS

NEGRO

COLORES DISPONIBLES · AVAILABLE COLORS |





wall: PERLA VENATA 120 NEGRO (60x120 cm), DECORADO 2 VICTORY 120 NEGRO-SILVER (60x120 cm).  
floor: PERLA VENATA 120 GRIS (60x120 cm).



wall: DECORADO 2 VICTORY 120 BLANCO-GOLD (60x120 cm).  
floor: PERLA VENATA 120 BLANCO (60x120 cm).

| PIEZAS DECORATIVAS · DECORATIVE PIECES |

DECORADO 2 VICTORY 120 | 60x120 cm | P94

Colocación y mantenimiento de baldosas cerámicas con recubrimiento PVD. Página 328. Formado por dos piezas. Prestar atención a la continuidad del diseño durante la colocación. Unidad de venta: 1 caja.  
Placement and maintenance of ceramic tiles with PVD coating. Page 329. Set of two matching pieces. Please pay attention to design ongoing graphic during tile installation. Sales unit: 1 box.



CREMA-GOLD



GRIS-SILVER



BLANCO-GOLD

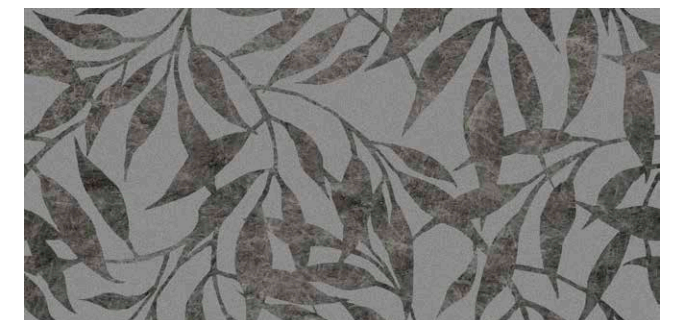

NEGRO-SILVER





wall: PERLA VENATA 120 BLANCO (60x120 cm), MOSAICO PERLA VENATA LEAF CREMA (28,4x29,5 cm).  
floor: PERLA VENATA 120 CREMA (60x120 cm).





wall: LACIO SOFT 120 ARENA (60x120cm), LEGNO 20/30 NOCE (19,4x120cm/30x120cm)  
 floor: LACIO SOFT 120 ARENA (60x120cm), LACIO DRY 120 ARENA (60x120cm).

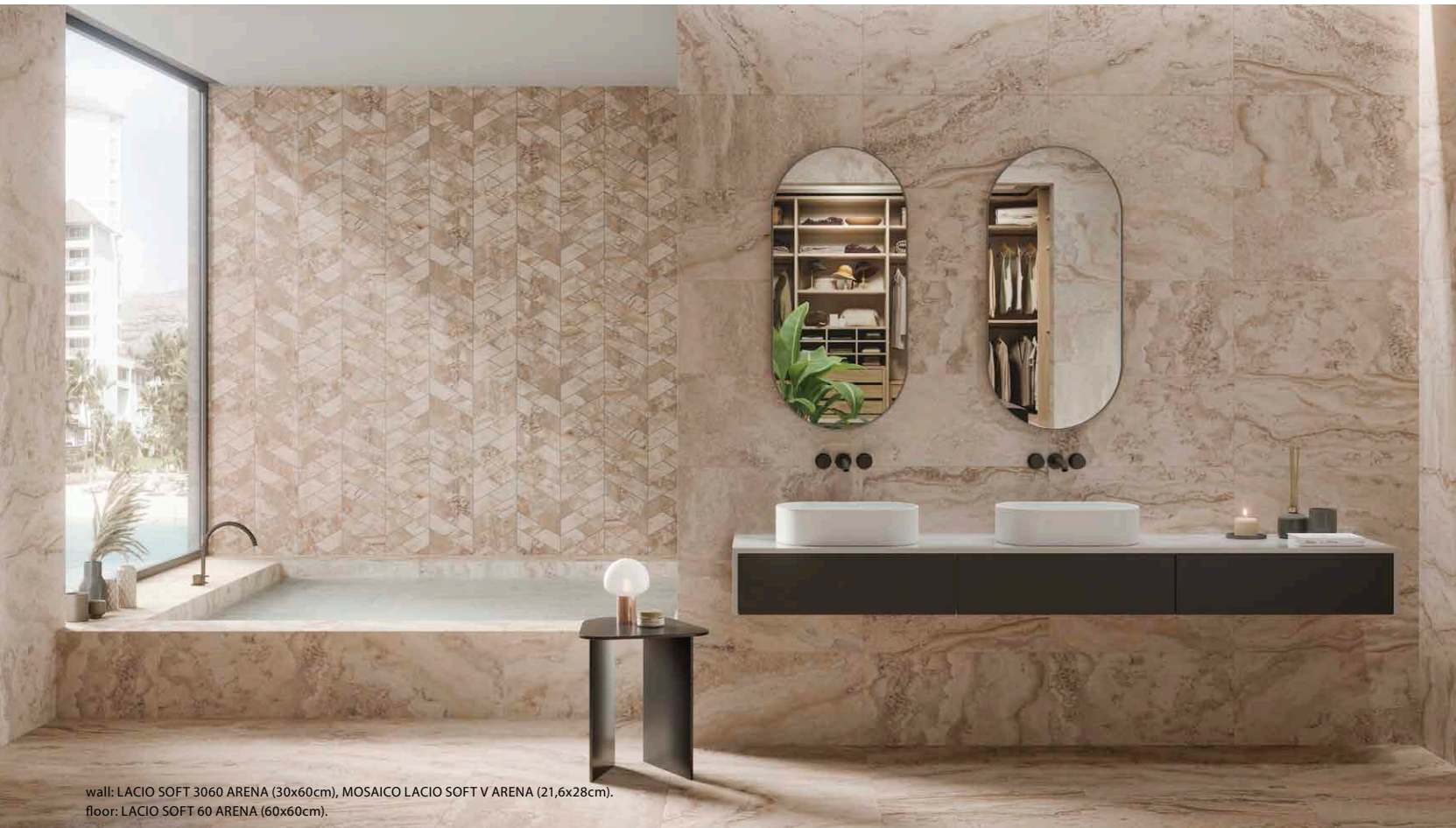

wall: LACIO SOFT 3060 ARENA (30x60cm), MOSAICO LACIO SOFT V ARENA (21,6x28cm).  
 floor: LACIO SOFT 60 ARENA (60x60cm).

# TRAVERTINE LACIO collection

| PORCELÁNICO · PORCELAIN | RECTIFICADO · RECTIFIED | DESTONIFICADO V3 · DESTONIFIED V3 |

60x120 cm 23,6"x47,2"	60x60 cm 23,6"x23,6"	21,6x28 cm 8,5"x11"
		30x60 cm 11,8"x23,6"

FORMATOS DISPONIBLES AVAILABLE FORMATS	ACABADO LAPADO MATE MATT LAPATTO FINISH	ACABADO ANTIDESLIZANTE SLIP RESISTANCE FINISH
60x120 cm · 23,6"x47,2"	LACIO SOFT 120   B83	LACIO DRY 120   B86
	DECORADO LILY SOFT 120   B80	---
60x60 cm · 23,6"x23,6"	LACIO SOFT 60   B37	---
30x60 cm · 11,8"x23,6"	LACIO SOFT 3060   B37	---
25x25 cm · 9,8"x9,8"	LACIO MOSAIC BRICK AGATA   P19 (ivory)	---
21,6x28 cm · 8,5"x11"	MOSAICO LACIO SOFT V   P12	---



IVORY



LACIO MOSAIC BRICK AGATA (25x25 cm).

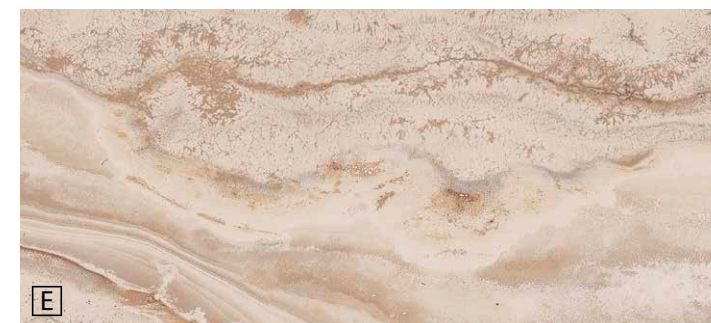

ARENA



IVORY

COLORES DISPONIBLES - AVAILABLE COLORS





wall: LACIO SOFT 120 IVORY (60x120cm), DECORADO LILY SOFT 120 IVORY (60x120cm), TIVOLI SOFT 120 KIDDLE IVORY (60x120cm).  
floor: LACIO SOFT 120 IVORY (60x120cm).



wall: DECORADO LILY SOFT 120 IVORY (60x120cm), SLATS LEGNO 120 ROVERE (18,5x120cm).

| PIEZAS DECORATIVAS · DECORATIVE PIECES |

DECORADO LILY SOFT 120 | 60x120 cm | B80

Cinco piezas diferentes. Unidad de venta: 1 caja. - Five different pieces. Sales unit: 1 box.

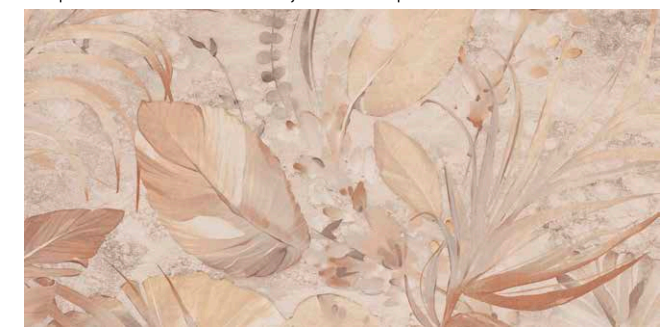

ARENA



IVORY





wall: TIVOLI SOFT 120 IVORY (60x120cm), MOSAICO TIVOLI SOFT PICKET IVORY (27,4x29,8cm).  
floor: TIVOLI DRY 120 IVORY (60x120cm).



wall: TIVOLI SOFT 3060 IVORY Y ARENA (30x60cm), MOSAICO TIVOLI SOFT 120 PICKET IVORY (27,4x29,8cm).  
floor: TIVOLI SOFT 120 ARENA (60x120cm).

# TRAVERTINE TIVOLI collection

| PORCELÁNICO · PORCELAIN | RECTIFICADO · RECTIFIED | DESTONIFICADO V2 · DESTONIFIED V2 |

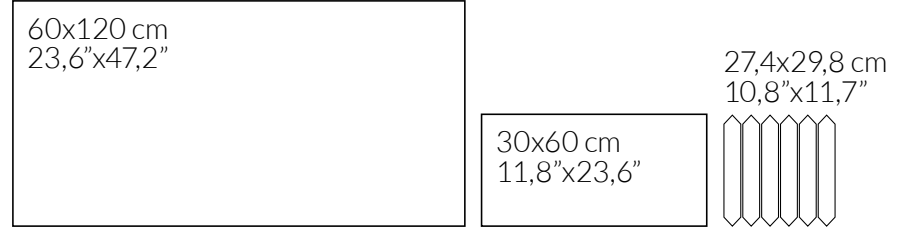

FORMATOS DISPONIBLES AVAILABLE FORMATS	ACABADO LAPADO MATE MATT LAPATTO FINISH 	ACABADO ANTIDESLIZANTE SLIP RESISTANCE FINISH 
60x120 cm · 23,6" x 47,2"	TIVOLI SOFT 120   B83  TIVOLI SOFT 120 KIDDLE   B80	TIVOLI DRY 120   B86
30x60 cm · 11,8" x 23,6"	TIVOLI SOFT 3060   B37	---
29,7x34,5 cm · 11,7" x 13,6"	TIVOLI MOSAIC HEX CROCHETE   P18  (arena)	---
27,4x29,8 cm · 10,8" x 11,7"	MOSAICO TIVOLI SOFT PICKET   P15	---
TAMAÑO DEL LIENZO: 131x260 cm · GRAPHIC CHART SIZE: 51,6" x 102,4"		



ARENA



TIVOLI MOSAIC HEX CROCHETE ARENA (29,7x34,5 cm).

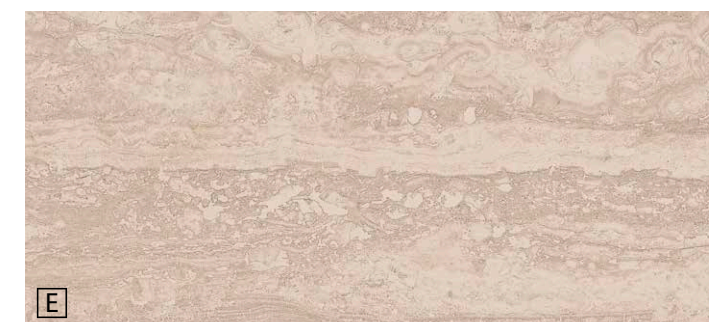

ARENA



IVORY

COLORES DISPONIBLES · AVAILABLE COLORS





wall: TIVOLI SOFT 120 IVORY Y ARENA (60x120cm), TIVOLI SOFT 120 KIDDLE IVORY (60x120cm), MOSAICO TIVOLI SOFT PICKET ARENA (27,4x29,8cm).  
 floor: TIVOLI SOFT 120 ARENA (60x120cm).

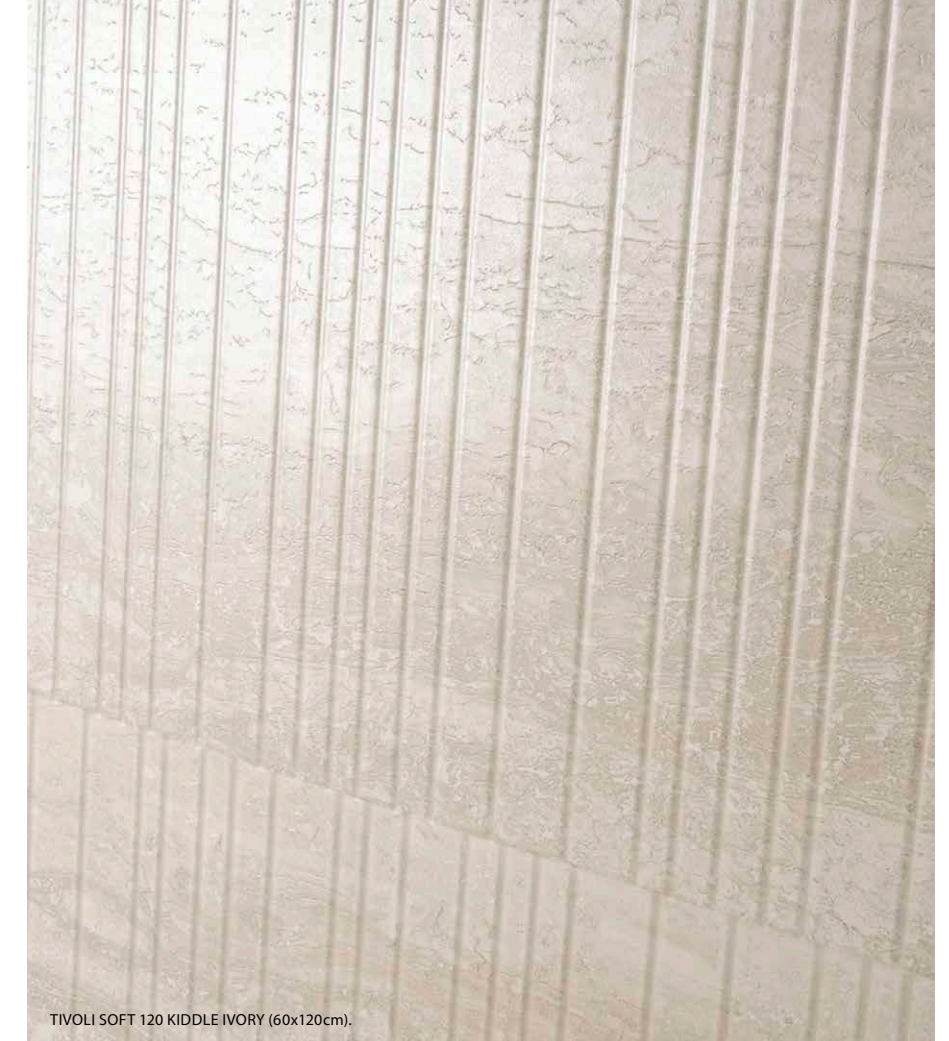

TIVOLI SOFT 120 KIDDLE IVORY (60x120cm).

| PIEZAS DECORATIVAS · DECORATIVE PIECES |

TIVOLI SOFT 120 KIDDLE | 60x120 cm | **B80**

Cuatro piezas diferentes. Unidad de venta: 1 caja. · Four different pieces. Sales unit: 1 box.

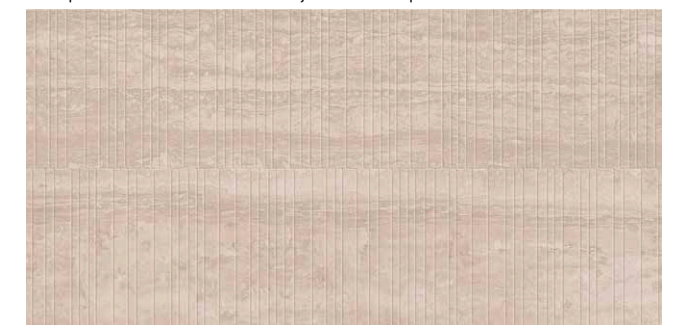

ARENA



IVORY





floor: VICHY LUX 60 BLANCO (60x60 cm).



wall: VICHY R90 GRIS (30x90 cm), DECORADO LAURIER R90 GRIS (30x90 cm).  
floor: VICHY LUX 60 BLANCO (60x60 cm).



# VICHY

collection

| PORCELÁNICO · PORCELAIN | RECTIFICADO · RECTIFIED | DESTONIFICADO V2 · DESTONIFIED V2 |

| ESCALA DE LA GRÁFICA 1/2 · GRAPHIC SCALE 1/2 |

60x60 cm  
23,6"x23,6"

<p>FORMATOS DISPONIBLES AVAILABLE FORMATS</p>	<p>ACABADO LAPADO BRILLO GLOSSY LAPATTO FINISH</p> 
<p>60x60 cm · 23,6"x23,6"</p>	<p>VICHY LUX 60   B37</p>
<p>TAMAÑO DEL LIENZO: 195x345 cm · GRAPHIC CHART SIZE: 76,8"x135,8"</p>	



**E**  
CREMA

**E**  
BLANCO

**E**  
GRIS

| COLORES DISPONIBLES · AVAILABLE COLORS |





wall: VICHY R90 CREMA (30x90 cm), DECORADO LAURIER R90 CREMA (30x90 cm), LEGNO R90 TRAIL ROVERE (30x90 cm).  
 floor: VICHY LUX 60 CREMA (60x60 cm), LEGNO 20 ROVERE (19,4x120 cm).

# VICHY collection

| PORCELÁNICO · PORCELAIN | RECTIFICADO · RECTIFIED | DESTONIFICADO V2 · DESTONIFIED V2 |

| ESCALA DE LA GRÁFICA 1/2 · GRAPHIC SCALE 1/2 |

30x90 cm  
 11,8"x35,4"

FORMATOS DISPONIBLES AVAILABLE FORMATS	ACABADO BRILLO GLOSSY FINISH 
30x90 cm · 11,8"x35,4"	VICHY R90   B42 DECORADO LAURIER R90   B42 (crema, gris)
Nº DISEÑOS POR FORMATO · Nº DESIGNS BY FORMAT:   30x90: 10	

| PIEZAS DECORATIVAS · DECORATIVE PIECES |

DECORADO LAURIER R90 | 30x90 cm | B42



CREMA



GRIS



CREMA



BLANCO



GRIS

| COLORES DISPONIBLES · AVAILABLE COLORS |





wall: VULCANO LUX 120 BASALTO Y QUARZO (60x120 cm), MOSAICO VULCANO LUX T5 BASALTO (30x30 cm).  
 floor: VULCANO LUX 120 QUARZO (60x120 cm).

# VULCANO collection

| PORCELÁNICO · PORCELAIN | RECTIFICADO · RECTIFIED | DESTONIFICADO V3 · DESTONIFIED V3 |

60x120 cm 23,6"x47,2"	60x60 cm 23,6"x23,6"	30x30 cm 11,8"x11,8"
		30x60 cm 11,8"x23,6"

FORMATOS DISPONIBLES AVAILABLE FORMATS	ACABADO LAPADO BRILLO · GLOSSY LAPATTO FINISH
60x120 cm · 23,6"x47,2"	VULCANO LUX 120   B90
60x60 cm · 23,6"x23,6"	VULCANO LUX 60   B39
30x60 cm · 11,8"x23,6"	VULCANO LUX 3060   B39
29,7x34,5 cm · 11,7"x13,6"	VULCANO MOSAIC HEX FOLIAGE   P18 (quarzo)
30x30 cm · 11,8"x11,8"	MOSAICO VULCANO LUX T5   P71
25x25 cm · 9,8"x9,8"	VULCANO MOSAIC BRICK FOLIAGE   P19 (quarzo)
TAMAÑO DEL LIENZO: CINCO LIENZOS 71x181 cm · GRAPHIC CHART SIZE: FIVE GRAPHIC CHARTS 28"x71,3"	

| PIEZAS DECORATIVAS · DECORATIVE PIECES |

VULCANO MOSAIC HEX FOLIAGE  
| 29,7x34,5 cm | P18

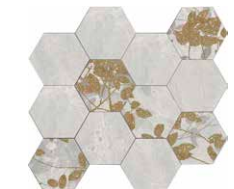

QUARZO

VULCANO MOSAIC BRICK FOLIAGE  
| 25x25 cm | P19



QUARZO



VULCANO MOSAIC HEX FOLIAGE QUARZO (29,7x34,5 cm).



MAGMA



QUARZO

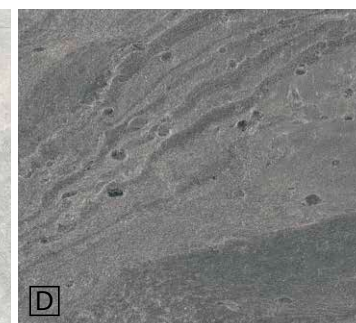

BASALTO

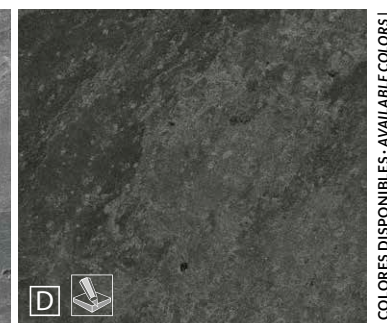

ANTRACITE

COLORES DISPONIBLES · AVAILABLE COLORS





wall: VULCANO LUX 120 QUARZO Y ANTRACITE (60x120 cm), MOSAICO VULCANO LUX T5 QUARZO Y ANTRACITE (30x30 cm).  
 floor: VULCANO LUX 120 ANTRACITE (60x120 cm).



wall: VULCANO LUX 120 QUARZO (60x120 cm).  
 floor: VULCANO LUX 60 MAGMA (60x60 cm).



wall: DELHI 20 ASH (19,4x120 cm).  
 floor: VULCANO LUX 60 ANTRACITE (60x60 cm).





**SMALL SIZE, BIG IDEAS**

AURA - NEW	300 - 303
COLORS - NEW	304 - 307
ESSENZA - NEW	308 - 311
KALEIDOSCOPE - NEW	312 - 315
TURQUETA - NEW	316 - 319

**ONZA**  
BY AZTECA



# AURA collection



| PASTA BLANCA · WHITE BODY | NO RECTIFICADO · NON RECTIFIED | DESTONIFICADO V4 · DESTONIFIED V4 |

<p>FORMATOS DISPONIBLES AVAILABLE FORMATS</p>	<p>ACABADO MATE MATT FINISH</p>
<p>6,2x25 cm · 2,4"x9,8"</p>	<p>AURA 6x25   006</p> <p>DECORADO AURA 6x25   007</p>
<p>Nº DISEÑOS POR FORMATO · Nº DESIGNS BY FORMAT:   6,2x25: 63  </p>	

## | PIEZAS · PIECES |

AURA 6x25 | 6,2x25 cm | 006



SAGE



CLAY



WHITE



GREY



GRAPHITE



CORAL



GARNET

## | PIEZAS DECORATIVAS · DECORATIVE PIECES |

DECORADO AURA 6x25 | 6,2x25 cm | 007

Doce piezas diferentes. Unidad de venta: 1 caja. Twelve different pieces. Sales unit: 1 box.



SAGE



CORAL



SAGE

CLAY

WHITE

GREY

GRAPHITE

CORAL

GARNET



wall: AURA 6x25 WHITE (6,2x25 cm), DECORADO AURA 6x25 SAGE (6,2x25 cm).  
floor: STREET 120 SAND (60x120 cm).





wall: AURA 6x25 WHITE (6,2x25 cm).

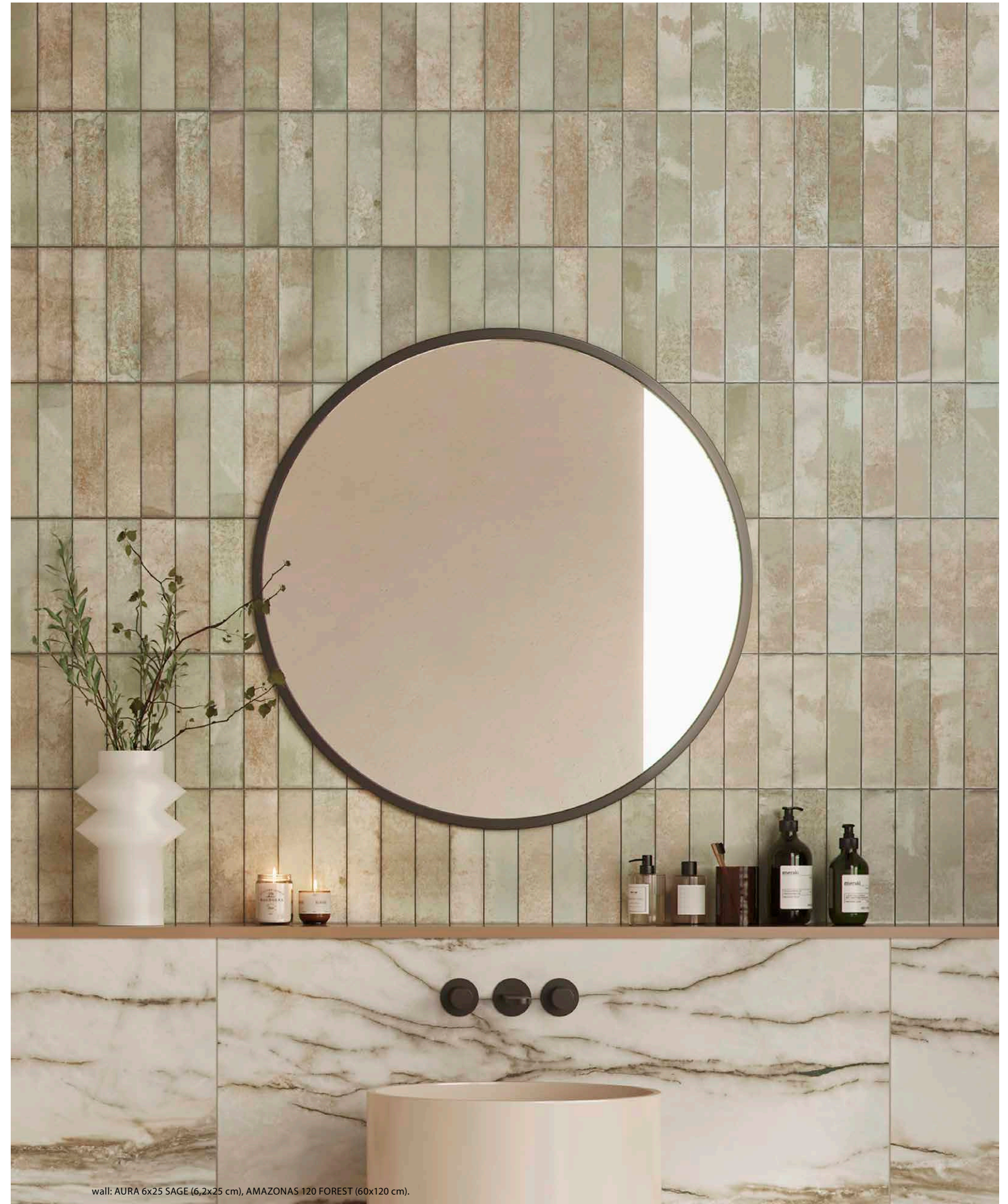

wall: AURA 6x25 SAGE (6,2x25 cm), AMAZONAS 120 FOREST (60x120 cm).



# COLORS collection

| PASTA BLANCA · WHITE BODY | NO RECTIFICADO · NON RECTIFIED | DESTONIFICADO V1 · DESTONIFIED V1 |



| PIEZAS · PIECES |

COLORS 5x25 MATT | 5x25 cm | 013



COLORS 5x25 GLOSSY | 5x25 cm | 013

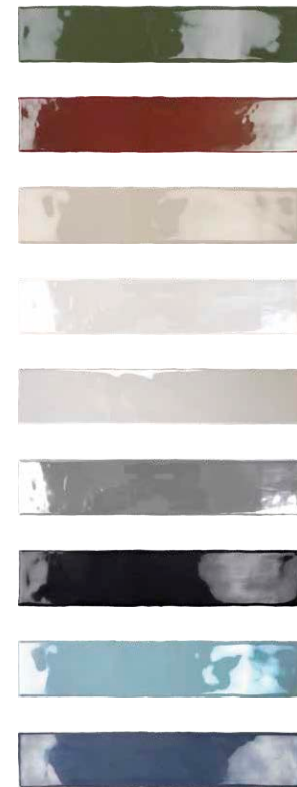

FORMATOS DISPONIBLES AVAILABLE FORMATS	ACABADO MATE MATT FINISH	ACABADO BRILLO GLOSSY FINISH
5x25 cm · 2"x9,8"	COLORS 5x25 MATT   013	COLORS 5x25 GLOSSY   013
5x50 cm · 2"x19,7"	COLORS 5x50 MATT   014	COLORS 5x50 GLOSSY   014
Nº DISEÑOS POR FORMATO · Nº DESIGNS BY FORMAT:   5x50: 3   5x25: 3		

wall: COLORS 5x50 BLACK MATT and GLOSSY (5x50 cm), PERLA VENATA LUX 120 NEGRO Y GRIS,  
DECORADO 2 VICTORY NEGRO-SILVER (60x120 cm).  
floor: PERLA VENATA 120 GRIS (60x120 cm).

| PIEZAS · PIECES |

COLORS 5x50 MATT | 5x50 cm | 014



COLORS 5x50 GLOSSY | 5x50 cm | 014

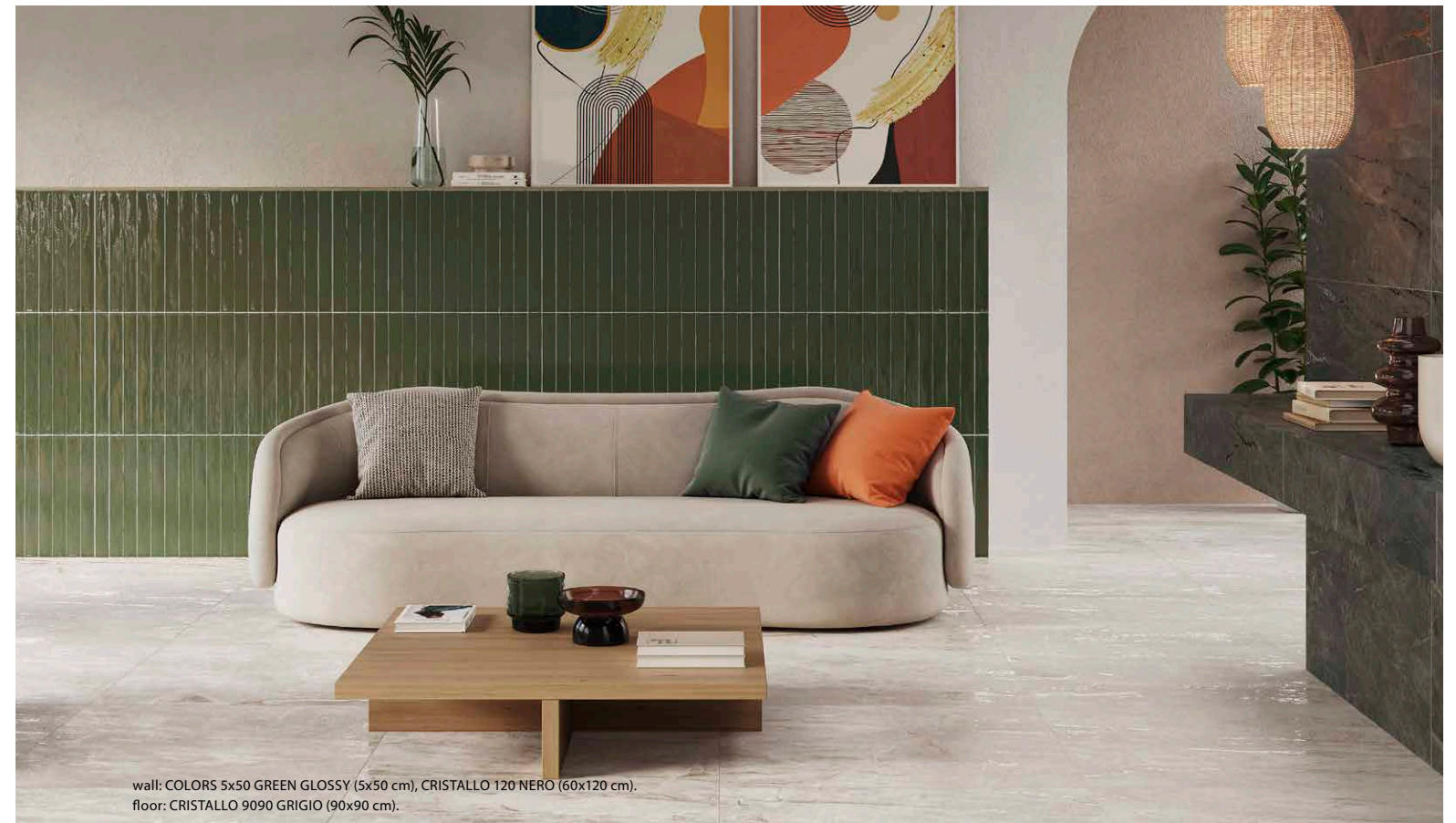

wall: COLORS 5x50 GREEN GLOSSY (5x50 cm), CRISTALLO 120 NERO (60x120 cm).  
floor: CRISTALLO 9090 GRIGIO (90x90 cm).





wall: COLORS 5x50 GLOSSY CREAM (5x50 cm), PARADOX LUX 120 GOLD (60x120 cm).  
floor: PARADOX LUX 120 GOLD (60x120 cm).

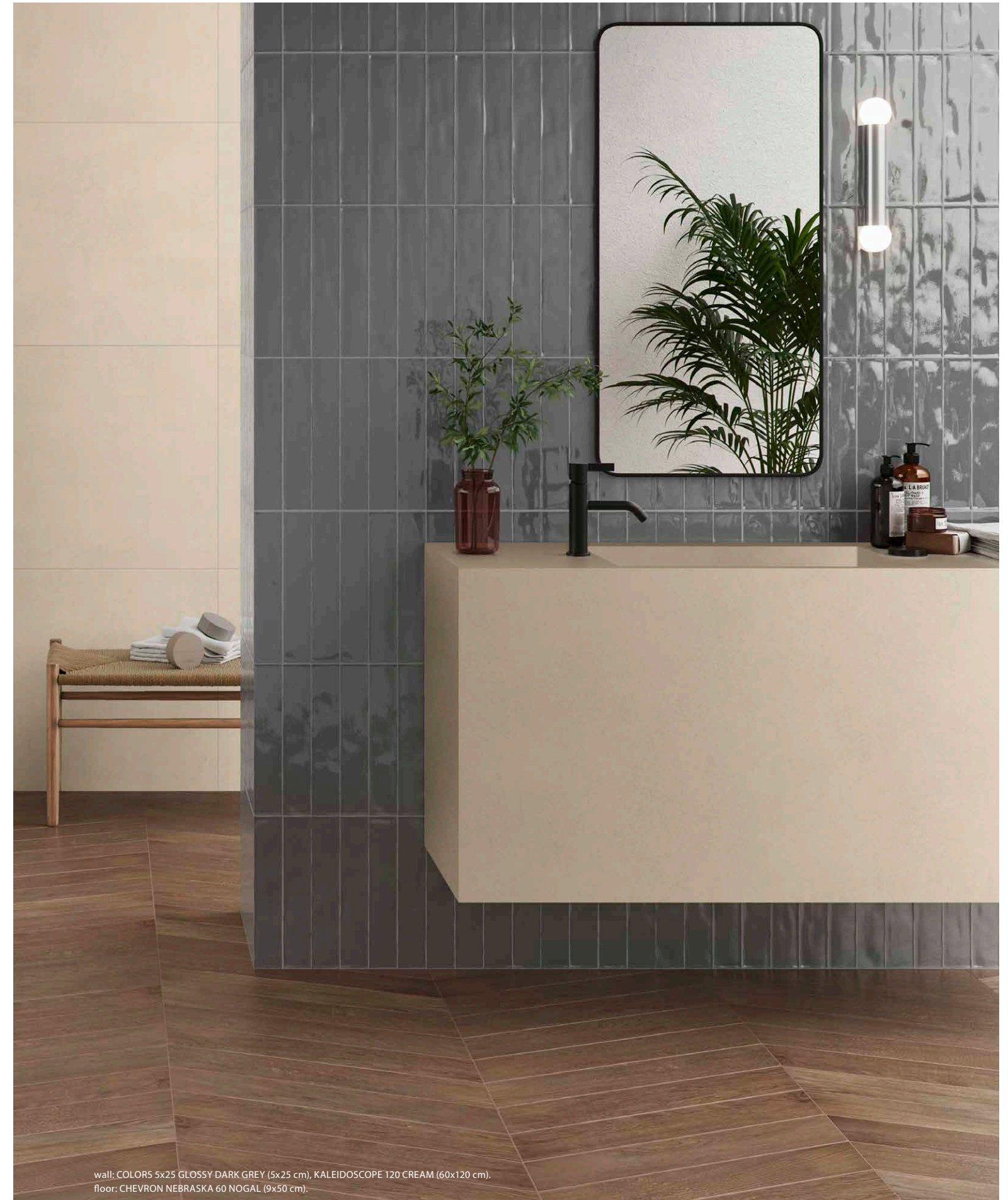

wall: COLORS 5x25 GLOSSY DARK GREY (5x25 cm), KALEIDOSCOPE 120 CREAM (60x120 cm).  
floor: CHEVRON NEBRASKA 60 NOGAL (9x50 cm).



# ESSENZA collection



| PORCELÁNICO · PORCELAIN | NO RECTIFICADO · NON RECTIFIED | DESTONIFICADO V3 · DESTONIFIED V3 |

FORMATOS DISPONIBLES AVAILABLE FORMATS	ACABADO NATURAL NATURAL FINISH 
15x15 cm · 5,9"x5,9"	ESSENZA 15x15   001
	DECORADO FLOWER 15x15   002
	DECORADO RUSTIC 15x15   002
Nº DISEÑOS POR FORMATO · Nº DESIGNS BY FORMAT:   15x15: 12	

## | PIEZAS · PIECES |

ESSENZA 15x15 | 15x15 cm | 001



## | PIEZAS DECORATIVAS · DECORATIVE PIECES |

DECORADO FLOWER 15x15 | 15x15 cm | 002

Doce piezas diferentes. Unidad de venta: 1 caja. Twelve different pieces. Sales unit: 1 box.



DECORADO RUSTIC 15x15 | 15x15 cm | 002

Doce piezas diferentes. Unidad de venta: 1 caja. Twelve different pieces. Sales unit: 1 box.



wall: ESSENZA 15x15 WHITE (15x15 cm), DECORADO RUSTIC 15x15 BLUE (15x15 cm).  
floor: ESSENZA 15x15 BLUE (15x15 cm).





wall: ESSENZA 15x15 SIENA (15x15 cm), DECORADO FLOWER 15x15 SIENA (15x15 cm).



wall: DECORADO RUSTIC 15x15 BREEZE (15x15 cm).

**DECORADO FLOWER 15x15 WHITE | 15x15 cm | 002**

Doce piezas diferentes. Unidad de venta: 1 caja. Twelve different pieces. Sales unit: 1 box.

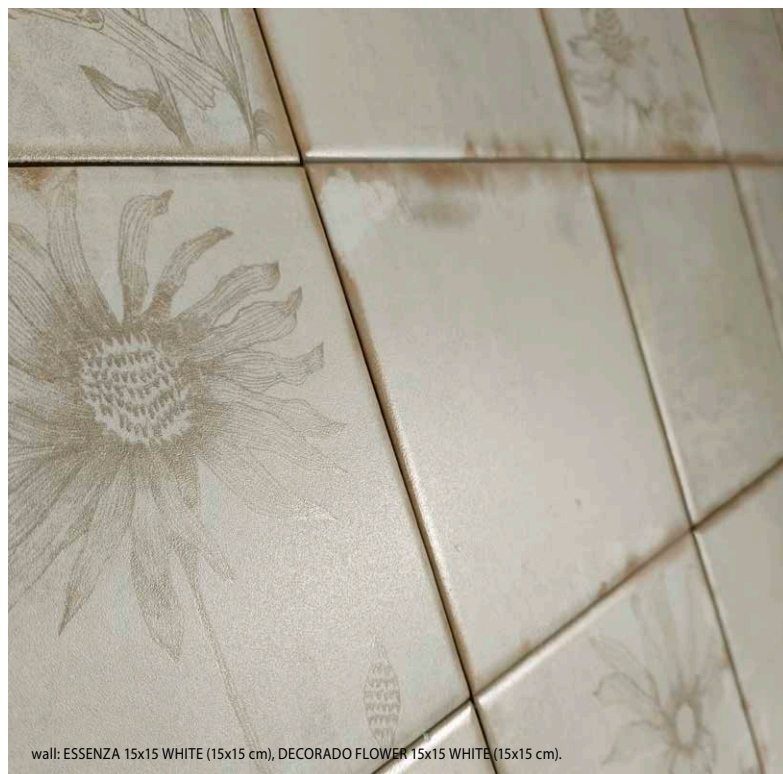

wall: ESSENZA 15x15 WHITE (15x15 cm), DECORADO FLOWER 15x15 WHITE (15x15 cm).

**DECORADO RUSTIC 15x15 BREEZE | 15x15 cm | 002**

Doce piezas diferentes. Unidad de venta: 1 caja. Twelve different pieces. Sales unit: 1 box.

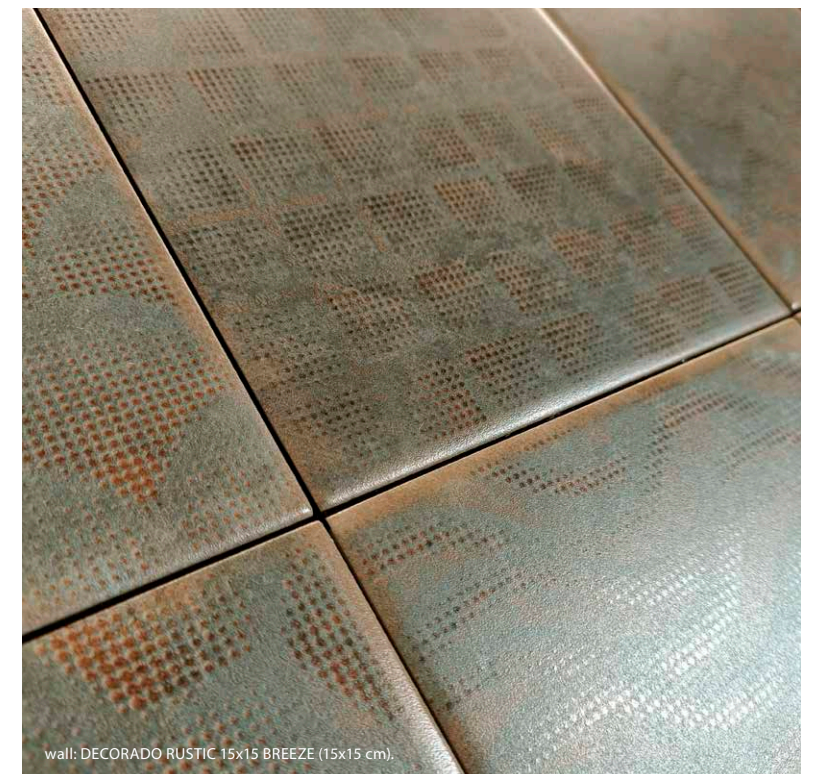
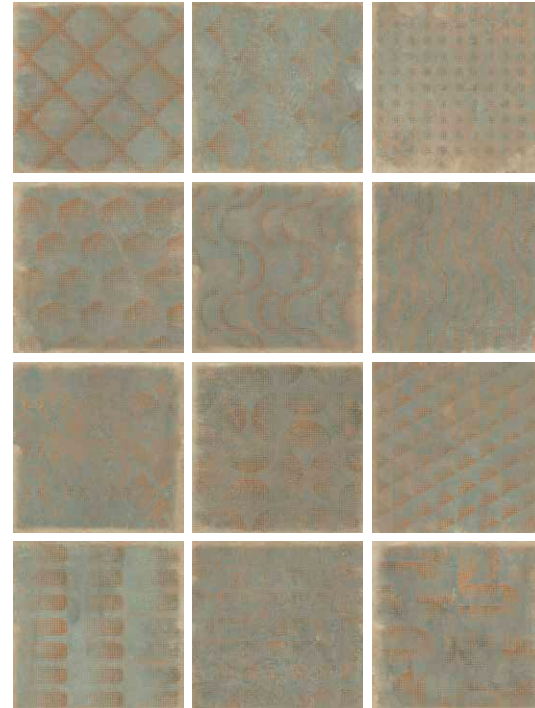

wall: DECORADO RUSTIC 15x15 BREEZE (15x15 cm).



# KALEIDOSCOPE collection



| PORCELÁNICO · PORCELAIN | NO RECTIFICADO · NON RECTIFIED | DESTONIFICADO V2 · DESTONIFIED V2 |

FORMATOS DISPONIBLES AVAILABLE FORMATS	ACABADO NATURAL · NATURAL FINISH 
20x20 cm · 7,9"x7,9"	KALEIDOSCOPE 2020   O09
	DECORADO AQUARELLE 2020   O10  (sage, warm)
TAMAÑO DEL LIENZO: 100x300 cm · GRAPHIC CHART SIZE: 39,4"x118,1"	

| PIEZAS · PIECES | KALEIDOSCOPE 2020 | 20x20 cm | 009

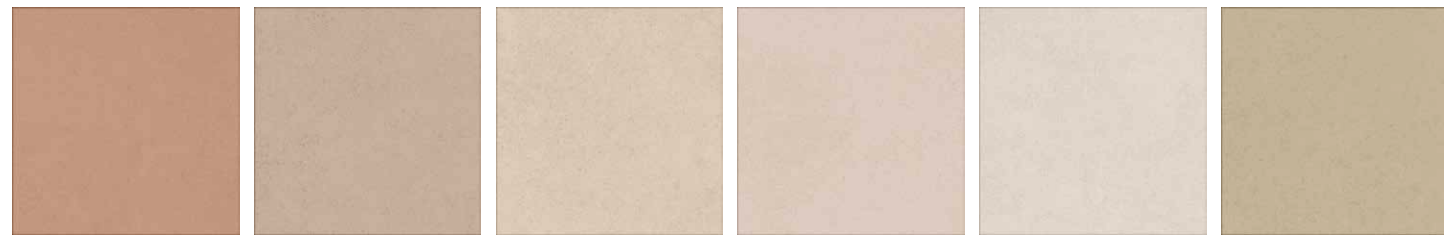

TERRACOTA TAUPE CREAM OFF WHITE WHITE SAGE

| PIEZAS DECORATIVAS · DECORATIVE PIECES | DECORADO AQUARELLE 2020 | 20x20 cm | 010 Nueve piezas diferentes. Unidad de venta: 1 caja. Nine different pieces. Sales unit: 1 box.



WARM SAGE

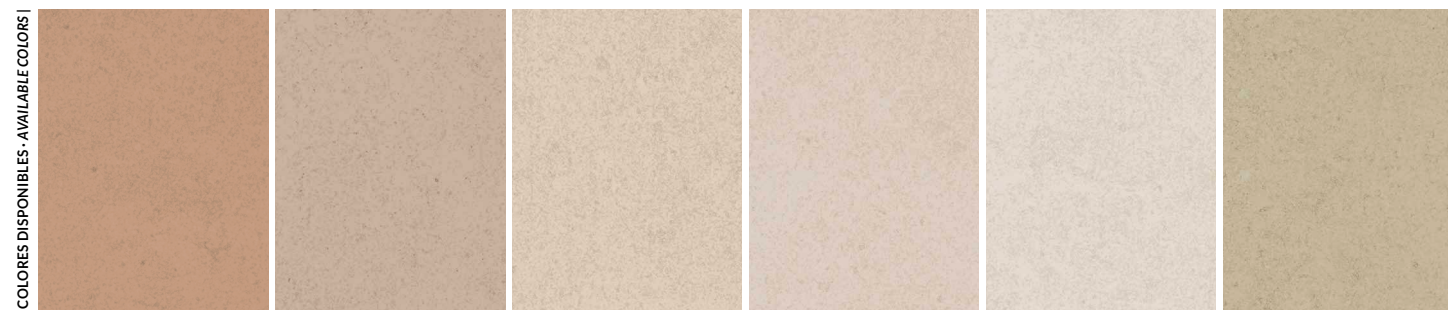

TERRACOTA TAUPE CREAM OFF WHITE WHITE SAGE

| COLORES DISPONIBLES · AVAILABLE COLORS |



floor: KALEIDOSCOPE 2020 CREAM (20x20 cm).



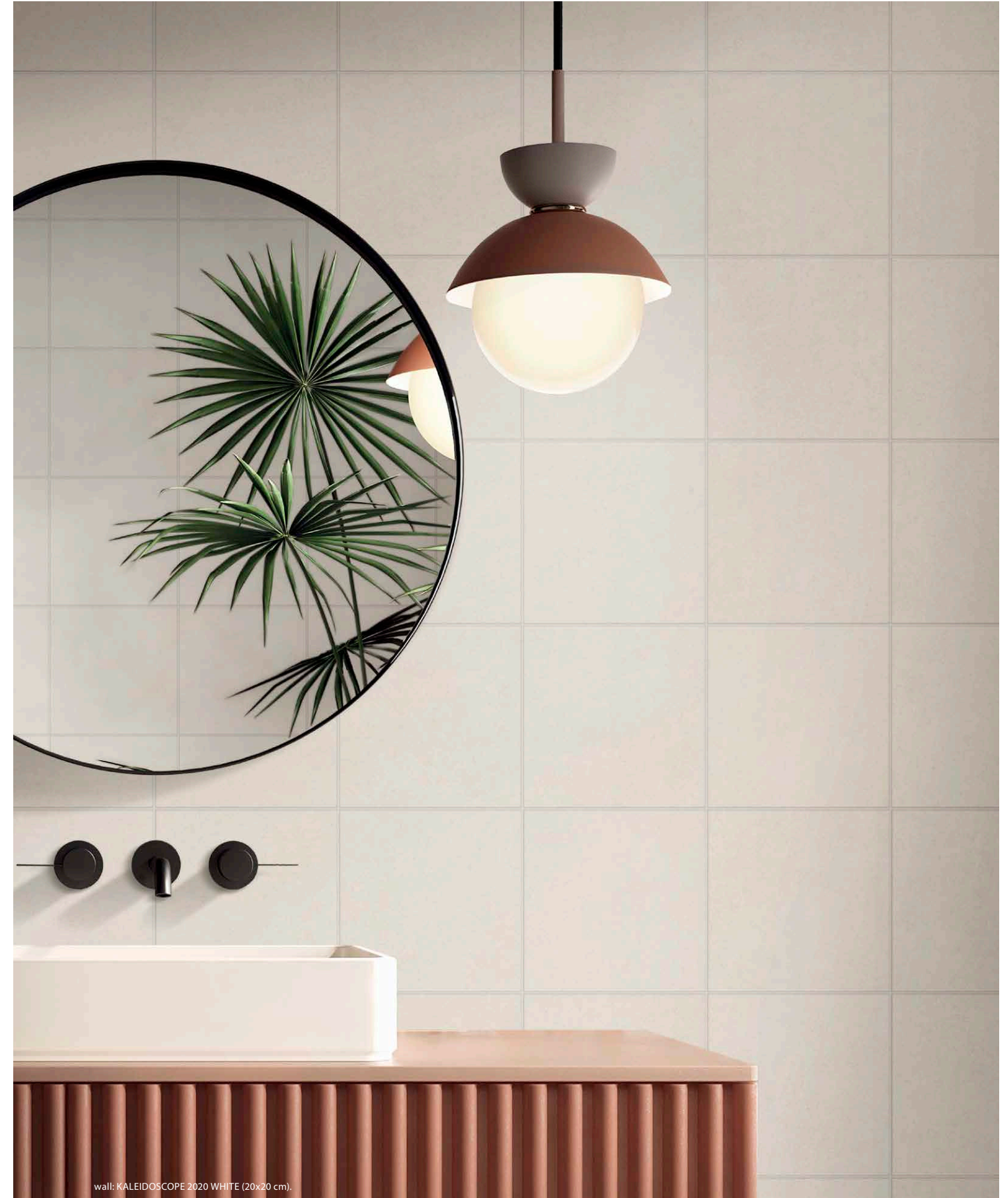



# TURQUETA collection



| PORCELÁNICO · PORCELAIN | NO RECTIFICADO · NON RECTIFIED | DESTONIFICADO V4 · DESTONIFIED V4 |

FORMATOS DISPONIBLES AVAILABLE FORMATS	ACABADO MATE · MATT FINISH	ACABADO BRILLO · GLOSSY FINISH
5x15 cm - 2"x5,9"	TURQUETA 5x15 MATT   012	TURQUETA 5x15 GLOSSY   012
Nº DISEÑOS POR FORMATO · Nº DESIGNS BY FORMAT:   5x15: 60		

## | PIEZAS · PIECES |

TURQUETA 5x15 MATT | 5x15 cm | 012



TURQUETA 5x15 GLOSSY | 5x15 cm | 012



wall: TURQUETA 5x15 WHITE GLOSSY (5x15 cm), PARADOX 120 GOLD (60x120 cm).



BLUE

WHITE

SALVIA

GREEN



wall: TURQUETA 5x15 SALVIA MATT (5x15 cm), KALEIDOSCOPE 120 TAUPE (60x120 cm).  
floor: KALEIDOSCOPE 120 WHITE (60x120 cm).





wall: TURQUETA 5x15 BLUE GLOSSY (5x15 cm), TURQUETA 5x15 BLUE MATT (5x15 cm).  
floor: NEBRASKA HEX60 JENGA ROBLE (52x60 cm).



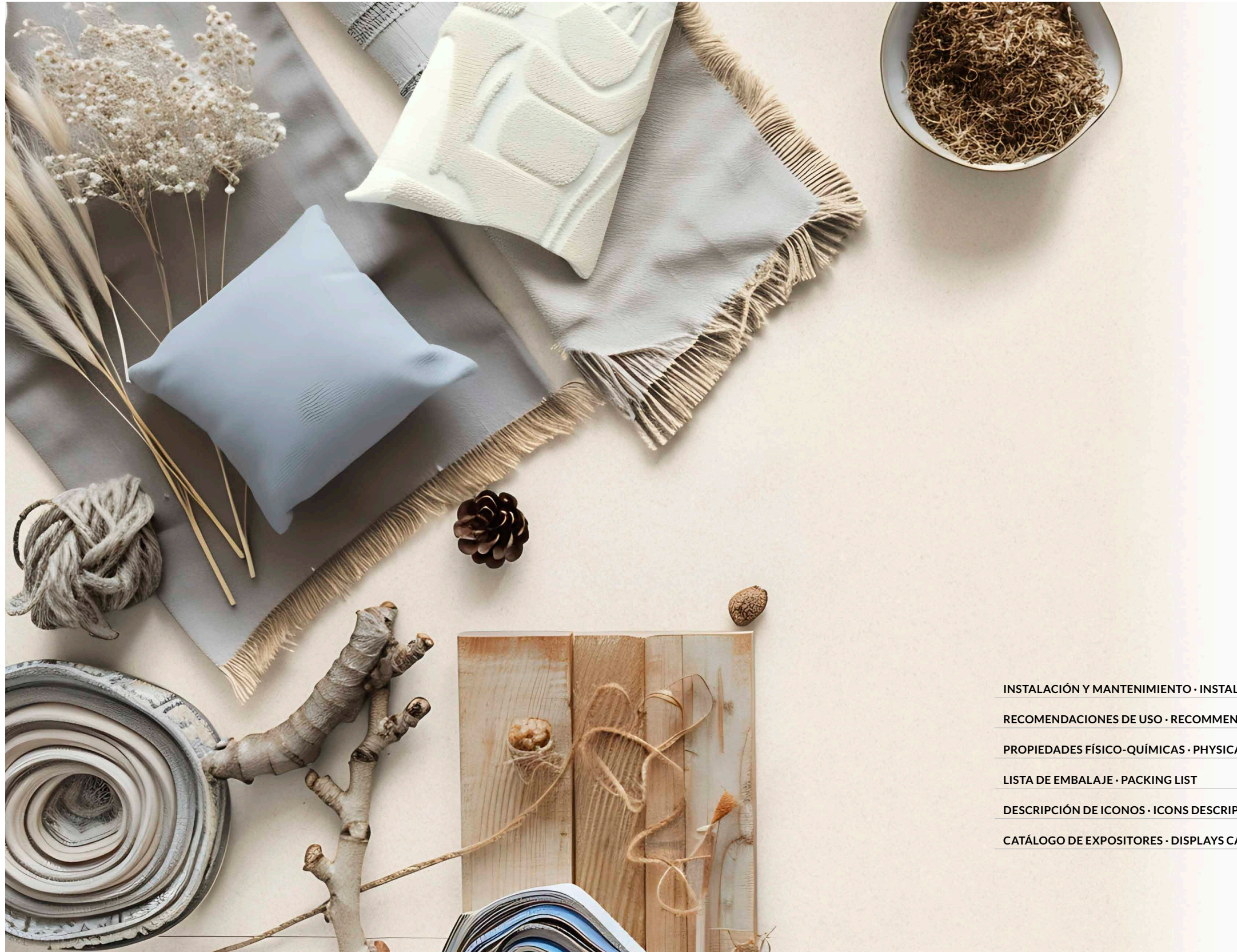

INSTALACIÓN Y MANTENIMIENTO · INSTALLATION AND MAINTENANCE	322 - 329
RECOMENDACIONES DE USO · RECOMMENDED USE	328 - 329
PROPIEDADES FÍSICO-QUÍMICAS · PHYSICAL AND CHEMICAL PROPERTIES	330 - 331
LISTA DE EMBALAJE · PACKING LIST	332 - 335
DESCRIPCIÓN DE ICONOS · ICONS DESCRIPTION	336
CATÁLOGO DE EXPOSITORES · DISPLAYS CATALOGUE	337 - 343



## INSTALACIÓN Y MANTENIMIENTO BALDOSA CERÁMICA

Los materiales cerámicos han experimentado una rápida evolución en los últimos años. Esta evolución se ha reflejado tanto en las baldosas cerámicas (bajas porosidades, grandes formatos,...) como en el destino de los locales en que se colocan (grandes áreas comerciales, fachadas, cámaras frigoríficas,...). Para una correcta planificación de las operaciones de embaldosado, hay que comenzar conociendo la naturaleza, el estado y el comportamiento de los soportes que han de ser revestidos, el sistema de colocación y el material de agarre, y por último, las juntas de pavimentación y alicatado, el rejuntado y el material de rejuntado.

### EL SOPORTE Y SUS CARACTERÍSTICAS:

Existen muchas razones por las cuales los soportes pueden no ser adecuados para fijar sobre ellos unas determinadas baldosas, con unos determinados adhesivos y con unas determinadas técnicas de colocación. Para lograr el objetivo final, que es la obtención de un revestimiento de alta calidad y gran durabilidad, se hace necesario partir de un soporte que esté preparado en condiciones óptimas para recibir la capa de agarre.

#### SOPORTE DE LADRILLOS CERÁMICOS:

Este tipo de soporte constituye una base ideal para recibir los revestimientos cerámicos. Este soporte es muy absorbente por lo que hay que controlar la temperatura ambiente y la hidratación. Se recomienda la aplicación de un enfoscado de cemento Portland y arena, ya que la colocación de ladrillos cerámicos no suele presentar una buena planitud.

#### SOPORTE DE FORJADO O SOLERA DE HORMIGÓN:

En la aplicación de baldosas cerámicas en este tipo de soporte es aconsejable realizar un diagnóstico previo realizando las operaciones necesarias para obtener una superficie apta para recibir la cerámica. Como norma general, es necesario la utilización de capas con distintas funciones (desolidarización, nivelación,...). Se recomienda que, para prevenir los posibles efectos de una inadecuada flexibilidad o estabilidad dimensional, el embaldosado debe independizarse del soporte mediante una capa de desolidarización que puede ser una base de arena, lámina de polietileno,... Posteriormente, es aconsejable la aplicación de una capa de nivelación para corregir irregularidades en la planeidad del soporte y poder aplicar convenientemente el material de agarre.

#### SOPORTE DE PANELES DE CARTÓN-YESO:

Para la fijación de baldosas cerámicas sobre paneles de cartón-yeso, hay que tener en cuenta que el peso de la capa de azulejos no ha de ser excesiva (se deben utilizar adhesivos extendidos en capa fina). Hay que asegurarse de que las superficies de los paneles, que han de recibir el recubrimiento cerámico, tienen que estar reforzadas y sujetas firmemente para evitar que se onduen o se deformen, de forma que no sufran ninguna distorsión durante o después de la fijación de los azulejos.

#### SOPORTE DE YESO:

Las superficies de yeso han de ser examinadas cuidadosamente antes de iniciar su alicatado. Es importante que exista una buena unión entre la base de yeso y el material de agarre por lo que es aconsejable dar una imprimación tapa poros. Se debe verificar la compatibilidad de uso del adhesivo con el yeso y la imprimación.

#### OTROS SOPORTES (Cerámico, terrazo o piedra natural, madera, hierro):

Existen soportes especiales sobre los cuales es necesario extremar los trabajos de preparación de la superficie de colocación:

- **Soporte cerámico:** en la aplicación de cerámica en rehabilitación es necesario limpiar bien con productos especiales para quitar grasas y otros residuos adheridos por el paso del tiempo (es aconsejable consultar previamente a los fabricantes sobre el procedimiento a seguir y los productos a utilizar).
- **Soporte de terrazo o piedra natural:** es necesario realizar una limpieza exhaustiva de la superficie del soporte ya que es uno de los factores clave para un buen encolado, sobretodo eliminar los restos de polvo ya que de lo contrario no existirá adherencia entre el soporte y el material de agarre y ocurrirán desprendimientos. En la piedra natural si ésta no ha sido mecanizada y tiene la superficie rugosa, hay que alisarla o nivelarla con mortero rico en cemento. Los materiales de agarre aconsejados son morteros cola con alto contenido en resinas poliméricas y resinas de reacción (epoxi o poliuretano).
- **Soporte de madera:** sobre soportes de madera es conveniente la aplicación de una imprimación impermeabilizante. El material de agarre aconsejado son resinas de reacción (epoxi o poliuretano).
- **Soporte de hierro:** es necesario preparar un soporte sano y limpio, exento de óxidos. El material de agarre aconsejado son resinas de reacción (epoxi o poliuretano).
- **Soporte de cristal:** para una correcta colocación de las series de cristal es necesario aplicar un adhesivo profesional poliuretánico bicomponente por su elevada elasticidad y deslizamiento vertical nulo. Se recomienda el uso de SUPERFLEX.

### EL SISTEMA DE COLOCACIÓN:

Para establecer el sistema de colocación deben tenerse en cuenta algunas consideraciones tales como el tipo y el tamaño de la baldosa, su ubicación en interiores o exteriores y las consideraciones anteriores sobre el soporte.

#### LA COLOCACIÓN EN CAPA FINA:

Constituye la técnica de colocación actual, adaptada a los modernos materiales cerámicos y a la diversidad de soportes existentes. La colocación se realiza sobre una capa previa de regularización del soporte, bien sea un enfoscado en las paredes o una base de mortero en los suelos. Es un sistema apto para cualquier tipo de baldosa y especialmente para piezas de baja porosidad y además es compatible con cualquier soporte. Existen materiales de agarre adaptados a cada tipo de colocación y el tiempo de rectificación es alto. Se recomienda el método de doble encolado en formatos superiores a 900 cm<sup>2</sup> (30x30 cm) mediante el uso de llana dentada.

#### RECOMENDACIONES DE CORTE:

Recomendamos el uso de herramientas de disco o cortes con agua para cortar material gres porcelánico, para conseguir un corte limpio y adecuado.

### EL MATERIAL DE AGARRE (ADHESIVOS):

Para una correcta colocación, se considera de vital importancia la elección de un material de agarre adecuado (también denominados adhesivos para la colocación de cerámica). Se recomienda seguir las directrices indicadas en la nueva norma **UNE 138002:12** como "Reglas generales para la ejecución de revestimientos con baldosas cerámicas por adherencia".

A continuación se describen los distintos materiales de agarre acordes a las diferentes solicitaciones, que quedan recogidos en la **UNE EN 212004** y se acompañan las tablas, para la correcta elección del adhesivo según el caso.

#### TIPOS DE ADHESIVOS (SEGÚN UNE EN 12004)

- **C** Adhesivo cementoso; morteros cola.
- **D** Adhesivo en dispersión; pastas adhesivas.
- **R** Adhesivo de resinas reactivas.

Estos adhesivos se pueden clasificar en dos clases:

- **1** normal.
- **2** mejorado.

Con tres características opcionales:

- **F** Fraguado rápido (para todos los adhesivos).
- **T** Deslizamiento reducido (para todos los adhesivos).
- **E** Tiempo abierto prolongado (solo cementosos y en dispersión).

La norma contempla además la característica de mejora en deformabilidad:

- **S1** Adhesivo deformable.
- **S2** Adhesivo muy deformable.

## INSTALLATION AND MAINTENANCE CERAMIC TILES

Ceramics have undergone a rapid evolution in the last few years. This has been reflected in as much as the ceramic tiles (low porosities, large formats...) as in the areas where they are put to use (large shopping centres, facades, refrigerating chambers...)

To optimise the planning of tiling operations one must first study the nature, condition and behaviour of the surface onto which the tiles are to be applied, the fixing system and adhering material, and lastly, the grouting and finishing materials for floor and wall tiles.

### THE SUPPORT SURFACE AND ITS FEATURES:

There are many reasons for which a surface may be considered inadequate for applying certain types of tiles with certain types of adhesives and with certain installation techniques. To achieve the final goal, which is a high quality and durable covering, it is necessary to begin with a surface which is prepared in the best possible way prior to applying the adhesive layer.

#### CERAMIC BRICK SUPPORT SURFACES:

This type of surface is ideal for ceramic coverings. It is very absorbent and therefore the ambient temperature and humidity must be controlled. A cement coating of sand mixed with Portland cement is recommended, as the surface is normally not level.

#### CONCRETE SLAB SUPPORT SURFACES:

When laying tiles onto this type of surface, it is recommended to first make a careful analysis of the surface, carrying out any necessary modifications to prepare the surface for the tiles. As a general rule, several layers, each having its own function, will be needed (insulating, levelling,...). It is highly recommended that, in order to avoid the negative effects brought about by a lack of flexibility or dimensional stability, the tile should be isolated from the surface with an isolating layer. This could be a sand base, a polyethylene membrane... Subsequently, it is a good idea to apply a levelling layer to correct any irregularities in the flatness of the surface and thus conveniently apply the adhering material.

#### PLASTER WALLBOARD SUPPORT SURFACES:

In order to adhere ceramic tiles to plaster wallboards, one must remember that the weight of the tile layer must not be excessive (adhesives should be applied in an evenly applied thin layer). It is essential to ensure that the panels which are to receive the ceramic tiles are correctly reinforced and attached so they do not warp in any way or become deformed during installation, or afterwards.

#### PLASTER SUPPORT SURFACES:

Plaster surfaces must be carefully inspected before proceeding with any tiling work. It is essential that the fixing material bonds correctly to the plaster, so it is highly recommended to apply a sealant in order to close the pores. Check the compatibility of the plaster adhesive and the primer.

#### OTHER SUPPORT SURFACES (Ceramic, terrazzo or natural stone, wood, metal):

There are certain surfaces which need maximum preparation prior tiling.

- **Ceramic support surfaces:** when applying ceramics in restoration work, they need to be thoroughly cleaned with specialized products to remove all traces of grease and dirt which have adhered to the surface over time. It is recommended to consult the adhesive materials manufacturers to see which procedure is best to follow, and the best products to utilize.
- **Terrazzo or natural stone support surfaces:** the surface must be thoroughly cleaned before laying any tiles; all traces of dust must be removed to ensure optimum adhesion and avoid any posterior detaching. If the natural stone has not been smoothed and has a rough surface, it must be levelled and smoothed with a cement-rich mortar. Recommended fixing materials for this type of surface are adhesive mortars with a high polymeric resin content and reaction resins (epoxy or polyurethane).
- **Wood support surfaces:** on wood surfaces it is a good idea to apply a waterproofing sealant. The recommended adhesive material is a reaction resin (epoxy or polyurethane).
- **Metal support surfaces:** the surface must be clean and in good condition, free of any rust. The recommended adhesive materials are reaction resins (epoxy or polyurethane).
- **Fixing glass tiles:** to correctly apply the glass series, you need a professional polyurethane two-part adhesive, which offers elasticity and no vertical slippage. We recommend SUPERFLEX.

### THE INSTALLATION METHOD:

To determine the correct setting system, one must take into account the type and size of the tile, whether it is for interior or exterior applications, and the previously mentioned support surface considerations.

#### INSTALLATION UTILIZING A THIN ADHESIVE LAYER:

This is the most current installation system, adapted to modern ceramic materials and the wide variety of possible support surfaces. A preliminary layer is usually applied to plumb and level the support surface, whether it may be a coating on the walls, or a mortar base on the floors. This system is adequate for all types of tiles, especially low-porosity tiles, and is furthermore compatible with all types of support surfaces. There are adhesive products adapted to each type of setting system, and the workability time is high. The buttering and floating method is recommended on formats over 900 cm<sup>2</sup> by using a toothed trowel.

#### RECOMMENDED CUTS:

We recommend the use of circular tools or water jet cutters in order to cut stoneware material and to obtain a clean and suitable cut.

### ADHESIVE MATERIALS:

For optimum results, it is vital to select an adhesive which is appropriate (these are known as tile setting adhesives). It is recommended to follow the guidelines indicated in the new **UNE 138002** standard:12 as "General rules for the execution of coatings with ceramic tiles by adhesion."

The following describes the different gripping materials according to the different demands, which are listed in **UNE EN 212004**, and the tables are attached for the correct selection of the adhesive according to each case.

#### TYPES OF ADHESIVES (ACCORDING TO UNE EN 12004)

- **C** Cementitious adhesive; adhesive mortars.
- **D** Dispersion adhesives; adhesive pastes.
- **R** Reactive resin adhesives.

These adhesives can be classified into two classes:

- **1** normal.
- **2** improved.

With three optional features:

- **F** Fast setting (for all adhesives).
- **T** Reduced slippage (for all adhesives).
- **E** Extended open time (only cementitious and dispersion).

The standard also contemplates the "improved" characteristic in deformability:

- **S1** Deformable adhesive.
- **S2** Very deformable adhesive.



Las siguientes tablas muestran el tipo de adhesivo con las prestaciones mínimas que se debe seleccionar según el uso previsto del revestimiento cerámico. Los factores que determinan el tipo de adhesivo para cada uso son:

- El tipo de soporte de colocación.
- La capacidad de absorción de agua de la baldosa cerámica.
- La longitud del lado mayor de la misma.

Con el fin de asegurar que el adhesivo elegido es el adecuado, es siempre recomendable comprobar las especificaciones técnicas del fabricante.

**SELECCIÓN DEL ADHESIVO ADECUADO PARA PAVIMENTOS:**

PAVIMENTOS INTERIORES RESIDENCIALES Y DE PÚBLICA CONCURRENCIA PAETONAL:										
CAPACIDAD DE ABSORCIÓN DE AGUA DE LA BALDOSA		<=3%				>3%				
LONGITUD DEL LADO MÁS LARGO DE LA BALDOSA EN CM		<=30	<=60	<=90	>90	<=30	<=60	<=90	>90	
TIPOS SOPORTES	Recrido cementoso con calefacción radiante	C2	C2S1	C2S2	C2	C2S1	C2S2			
	Recrido cementoso sin calefacción radiante	C1	C2		C(i)	C1	C2			
	Recrido de base de sulfato cálcico (anhidrita) con	C2	C2S1	C2S2	C2	C2S1	C2S2			
	Recrido de base de sulfato cálcico (anhidrita) sin	C1	C2		C1	C2				
	Forjado o solera de hormigón	C2	C2S1	C2S2	C1	C2	C2S1			
	Baldosas/ mosaico/ piedras preexistentes	C2			C2					
	Superficies de metal	R1*			---	R1*			---	

PAVIMENTOS INTERIORES COMERCIALES O USO INDUSTRIAL Y EXIGENCIAS MECÁNICAS					
CAPACIDAD DE ABSORCIÓN DE AGUA DE LA BALDOSA		PARA CUALQUIERA			
LONGITUD DEL LADO MÁS LARGO DE LA BALDOSA EN CM		<=30	<=60	<=90	>90
TIPOS SOPORTES	Recrido cementoso con calefacción radiante	C2	C2S1		C2S2
	Recrido cementoso sin calefacción radiante		C2		C2S1
	Forjado o solera de hormigón	C2			
	Baldosas/ mosaico/ piedras preexistentes	C2			
	Superficies de metal	R1*		R2*	---

NOTA: En pavimentos industriales con exigencias químicas es conveniente la selección de adhesivos R1 o R2 en base epoxi.

PAVIMENTOS EXTERIORES					
CAPACIDAD DE ABSORCIÓN DE AGUA DE LA BALDOSA		<=3%	>3%	PARA CUALQUIERA	
LONGITUD DEL LADO MÁS LARGO DE LA BALDOSA EN CM		<=30	<=60	<=90	>90
TIPOS SOPORTES	Recrido cementoso	C2	C1	C2S1	C2S2
	Losa o solera de hormigón		C2		
	Baldosas/ mosaico/ piedras preexistentes	C2S1			
	Superficies de metal	R1*		R2*	---

**SELECCIÓN DEL ADHESIVO ADECUADO PAREDES Y TECHOS:**

PAREDES Y TECHO INTERIORES									
CAPACIDAD DE ABSORCIÓN DE AGUA DE LA BALDOSA		<=3%				>3%			
LONGITUD DEL LADO MÁS LARGO DE LA BALDOSA EN CM		<=30	<=60	<=90	>90	<=30	<=60	<=90	>90
TIPOS SOPORTES	Revoque a base de cal/cemento con calefacción	C2/D1	C2S1	C2S2	C2/D1	C2S1	C2S2		
	Revoque a base de cal/cemento sin calefacción	C1/D1	C2		C(i)/D1	C1	C2		
	Revoque a base de yeso con calefacción radiante	C2/D1	C2S1	C2S2	C2/D1	C2S1	C2S2		
	Revoque a base de yeso sin calefacción radiante	C1/D1	C2		C1/D1	C1	C2		
	Ladrillo cerámico de gran formato	C1			C(i)/D1				
	Hormigón	C2/D1	C2	C2S1	C1	C2	C2S1		
	Baldosas/ mosaico/ piedras existentes	C2		C2S1	C2		C2S1		
	Paneles a base de cemento/ fibrocemento	C1/D1	C2	C2S1	C1/D1	C2			
	Superficies de madera	C2/D1/R1	C2S1/R1*		---	C2/D1/R1	C2S1/R1*	---	
	Paneles de cartón-yeso	C1/D1	C2	C2S1	---	C1/D1	C2	C2S1	---
	Superficies de metal	R1*			---	R1*			---

PAREDES Y TECHO INTERIORES					
CAPACIDAD DE ABSORCIÓN DE AGUA DE LA BALDOSA		PARA CUALQUIERA			
LONGITUD DEL LADO MÁS LARGO DE LA BALDOSA EN CM		<=30	<=60	<=90	>90
TIPOS SOPORTES	Revoque a base de cal/ cemento	C2S1 / D2	C2S1	C2S2	
	Hormigón		C2S2		
	Paneles a base de cemento / fibrocemento		C2S2		
	Superficies de metal	R1*		R2*	---

The following tables show the type of adhesive with the minimum performance that must be selected according to the intended use of the ceramic coating. The factors that determine the type of adhesive for each use are:

- The type of placement support.
- The water absorption capacity of ceramic tile.
- The length of its longest side.

In order to ensure that the chosen adhesive is suitable, it is always advisable to check the manufacturer's technical specifications.

**SELECTION OF ADEQUATE ADHESIVE FOR PAVEMENTS:**

RESIDENTIAL AND PUBLIC INTERIOR PAVEMENTS INTENDED FOR PUBLIC PEDESTRIAN USE:									
WATER ABSORPTION CAPACITY OF THE TILES		<=3%				>3%			
LENGTH OF THE LONGEST SIDE OF THE TILE IN CM		<=30	<=60	<=90	>90	<=30	<=60	<=90	>90
TYPES OF SUPPORT	Cement screed with radiant heating	C2	C2S1	C2S2	C2	C2S1	C2S2		
	Cement screed without radiant heating	C1	C2		C(i)	C1	C2		
	Calcium sulphate (anhydrite) screed base with radiant	C2	C2S1	C2S2	C2	C2S1	C2S2		
	Calcium sulphate (anhydrite) screed base without radiant	C1	C2		C1	C2			
	Concrete floor or slab	C2	C2S1	C2S2	C1	C2	C2S1		
	Tiles/ mosaic/ pre-existing stones	C2			C2				
	Metal surfaces	R1*			---	R1*			---

INTERIOR PAVEMENT FOR COMMERCIAL OR INDUSTRIAL AND MECHANICAL USE					
WATER ABSORPTION CAPACITY OF THE TILES		FOR ANY			
LENGTH OF THE LONGEST SIDE OF THE TILE IN CM		<=30	<=60	<=90	>90
TYPES OF SUPPORT	Cement screed with radiant heating	C2	C2S1		C2S2
	Cement screed without radiant heating		C2		C2S1
	Concrete floor or slab	C2			
	Tiles/ mosaic/ pre-existing stones	C2			
	Metal surfaces	R1*		R2*	---

NOTE: In industrial pavements with chemical requirements, it is recommended to select R1 or R2 adhesives in epoxy base.

EXTERIOR PAVEMENTS					
WATER ABSORPTION CAPACITY OF THE TILES		<=3%	>3%	FOR ANY	
LENGTH OF THE LONGEST SIDE OF THE TILE IN CM		<=30	<=60	<=90	>90
TYPES OF SUPPORT	Cement screed	C2	C1	C2S1	C2S2
	Concrete floor or slab		C2		
	Tiles/ mosaic/ pre-existing stones	C2S1			
	Metal surfaces	R1*		R2*	---

**ADEQUATE ADHESIVE SELECTION FOR WALLS AND CEILINGS:**

INTERIOR WALLS AND CEILINGS									
WATER ABSORPTION CAPACITY OF THE TILES		<=3%				>3%			
LENGTH OF THE LONGEST SIDE OF THE TILE IN CM		<=30	<=60	<=90	>90	<=30	<=60	<=90	>90
TYPES OF SUPPORT	Plastering on a lime/cement base with radiant	C2/D1	C2S1	C2S2	C2/D1	C2S1	C2S2		
	Plastering on a lime/cement base without	C1/D1	C2		C(i)/D1	C1	C2		
	Plastering on a plaster base with radiant	C2/D1	C2S1	C2S2	C2/D1	C2S1	C2S2		
	Plastering on a plaster base without radiant	C1/D1	C2		C1/D1	C1	C2		
	Large format ceramic brick	C1			C(i)/D1				
	Cement	C2/D1	C2	C2S1	C1	C2	C2S1		
	Tiles/ mosaic/ pre-existing stones	C2		C2S1	C2		C2S1		
	Cement/ fibre cement-based panels	C1/D1	C2	C2S1	C1/D1	C2			
	Wooden surfaces	C2/D1/R1	C2S1/R1*		---	C2/D1/R1	C2S1/R1*	---	
	Plaster-cardboard panels	C1/D1	C2	C2S1	---	C1/D1	C2	C2S1	---
	Metal surfaces	R1*			---	R1*			---

WALLS AND INTERIOR CEILINGS					
WATER ABSORPTION CAPACITY OF THE TILES		FOR ANY			
LENGTH OF THE LONGEST SIDE OF THE TILE IN CM		<=30	<=60	<=90	>90
TYPES OF SUPPORT	Plastering on a lime/ cement base	C2S1 / D2	C2S1	C2S2	
	Cement		C2S2		
	Cement/ fibre cement-based panels		C2S2		
	Metal surfaces	R1*		R2*	---



**INSTALACIÓN Y MANTENIMIENTO**  
BALDOSA CERÁMICA

**ESPECIAL COLOCACIÓN PARA LAS SERIES DESTONIFICADAS**

Para obtener un excelente acabado estético en cuanto al diseño y apreciar todas sus cualidades, se recomienda que se mezclen baldosas del mayor número de cajas posible antes de iniciar la instalación.

**ESPECIAL COLOCACIÓN GRANDES FORMATOS**

Para la instalación de grandes formatos (lado mayor de 60 cm.) y/o rectangulares se recomienda el uso de sistemas nivelados como campanas o cuñas para garantizar una correcta colocación.

El sistema de auto-nivelación se caracteriza por ventajas como el ahorro en tiempo de colocación o el auto-nivelado entre las piezas para conseguir una colocación totalmente plana.

La colocación a rompe-junta de grandes formatos y/o rectangulares nunca debe realizarse en la mitad de la pieza.

Se aconseja que para mantener la estética y evitar dificultades en su instalación, la colocación a rompe-junta no supere el 20% del lado sobre el que se aplica.

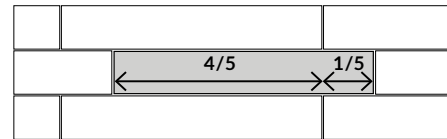
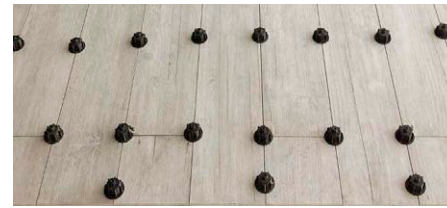

**LAS JUNTAS DE PAVIMENTACIÓN Y ALICATADO**

**JUNTAS DE COLOCACIÓN:**

Junta de colocación cerámica es la separación que se deja entre todas las baldosas cerámicas contiguas, ya sea intencionalmente por razones funcionales y/o estéticas, ya sea por la necesidad de compensar sus desviaciones dimensionales.

Respecto a las juntas de colocación, deben tenerse en cuenta los siguientes consejos:

- En general, se recomienda no hacer una colocación con una separación entre piezas inferior a 1'5mm (incluidos los productos rectificadas).
- En modelos de borde irregular, debe utilizarse una junta no inferior a 3mm.
- En modelos modulares (colocación de varios formatos de pieza juntos), aconsejamos una junta de 5mm para una correcta modulación.

**JUNTAS DE MOVIMIENTO:**

Zonas de interrupción inexcusable de los recubrimientos cerámicos, para absorber posibles variaciones dimensionales. Se clasifican en:

- **Juntas estructurales**, que son las que presenta la estructura del edificio. En este caso, se deberá respetar la junta proyectada en los forjados o paredes, prolongándola hasta en las baldosas coincidentes con ellas.
- **Juntas perimetrales**, que son las que se deben dejar en los límites de los suelos embaldosados con otros elementos tales como paredes, pilares, escalones, etc., para evitar la acumulación de tensiones; deben ser continuas y mayores de 5mm. Quedan ocultas por el rodapié, y deben rellenarse con un material elástico y llegar hasta el forjado cortando la solera.
- **Juntas de partición**, que son las que deben subdividir las grandes superficies revestidas con baldosas cerámicas, para evitar que se acumulen las dilataciones y contracciones. La superficie máxima a revestir sin estas juntas será de unos 60m<sup>2</sup> en interiores y de la mitad en exterior. No deben ser inferiores a 5 mm.

**EL REJUNTADO Y EL MATERIAL DE REJUNTADO**

**EL REJUNTADO:**

No es recomendable empezar la operación de rejuntado antes de que se haya endurecido el adhesivo. Una manipulación prematura podría perturbar la posición y adhesión de las baldosas.

El rejuntado se realiza con una espátula de goma o con una paleta de rejuntar. El material debe ser comprimido con movimientos de ida y vuelta para lograr que las juntas se llenen completamente.

**EL MATERIAL DE REJUNTADO:**

Existe una amplia variedad de materiales de rejuntado para baldosas cerámicas, que permiten adecuarse a los diversos tipos de baldosas y de ambientes. La mayoría de estos materiales contienen cemento en su composición y además otros componentes que exaltan algunas características específicas (blancura, resistencia a los hongos, uniformidad y textura, dureza, flexibilidad,...).

También existen otros materiales, como los epoxídicos, los orgánicos y las siliconas, que no contienen cemento y poseen propiedades inalcanzables con los materiales de cemento. Su colocación requiere mayor cuidado y habilidad por parte de los colocadores.

**Juntas cementosas:**

Constituidos por conglomerantes hidráulicos, cargas minerales y aditivos orgánicos, que sólo tienen que mezclarse con agua o adición líquida justo antes de su uso. Pueden contener pigmentos para proporcionar diversas coloraciones. Se dividen en dos clases, normal o mejorados, según dispongan de características adicionales (con absorción de agua reducida, con resistencia elevada a la abrasión,...). Se preparan añadiendo la cantidad de agua indicada por el fabricante para conseguir una pasta suficientemente espesa y homogénea. Existen en el mercado para juntas finas y para juntas anchas. Su campo de aplicación son los rejuntados de revestimientos de paramentos y suelos, tanto interiores como exteriores. Son compatibles con todos los tipos de baldosas. No es recomendable su empleo en locales sometidos a limpieza frecuente con productos agresivos y en locales de uso alimentario (cocinas colectivas, mataderos,...) o sanitario (quirófanos,...).

**Juntas de resinas reactivas:**

Constituidos por resinas sintéticas (generalmente epoxídica), aditivos orgánicos y cargas minerales, cuyo endurecimiento resulta de una reacción química. Están disponibles en uno o más componentes. Pueden contener pigmentos para proporcionar diversas coloraciones. Entre sus principales propiedades están la resistencia a productos químicos, resistencia bacteriológica, elevada adherencia, muy buena resistencia a la humedad, y excelente resistencia a la abrasión. Su campo de aplicación es el de los locales en los que se requiera asepsia, resistencia química, alta resistencia a la abrasión y alta resistencia a la humedad.

TIPO	NOMBRE
CG1	Material para juntas cementosas normales.
CG2	Material para juntas cementosas mejoradas.
RG	Material para juntas de resinas de reacción.

**RECOMENDACIÓN**

No se debe utilizar junta de color que contenga negro de humo (carbón micronizado), ni tintes que puedan dificultar la limpieza de las superficies revestidas.

**INSTALLATION AND MAINTENANCE**  
CERAMIC TILES

**SPECIAL ARRANGEMENT FOR DETONED SERIES**

In order to obtain an excellent aesthetic finish regarding design and to appreciate all their qualities, we recommend you mix floor tiles from different boxes before starting to arrange them.

**SPECIAL ARRANGEMENT FOR LARGE FORMATS**

For large (largest side of 60 cm.) and/or rectangular formats, we recommend the use of levelled systems such as bells or wedges in order to guarantee a proper arrangement.

The self-levelling system has some advantages such as saving time in arranging the pieces or the self-levelling among pieces in order to obtain a totally flat arrangement.

When laying rectangular formats discontinuously, never do so in the centre of the piece.

In order to maintain the aesthetic appearance and avoid difficulties in installation, we recommend that discontinuous laying does not exceed 20% of the side to which it is applied.

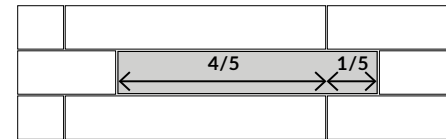
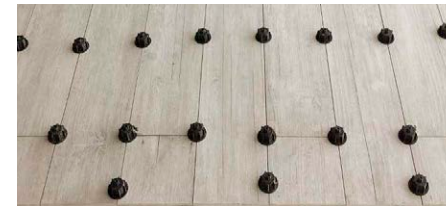

**WALL AND FLOOR TILE JOINTS**

**GROUT JOINTS:**

A tile joint is the separation between each ceramic tile and those adjacent. This gap may be functional or aesthetic, or used to compensate for any irregularities between the tiles' sizes.

With regards to these joints, the following considerations should be taken into account:

- Generally, a grout joint of not less than 1.5mm is recommended (including rectified products).
- For products with an irregular edge, a grout joint of not less than 3mm should be used.
- Concerning modulars (installing tiles together which have various formats) a grout joint of 5mm is recommended for correct modularity.

**EXPANSION JOINTS:**

These are areas of unavoidable interruption in the ceramic tiles in order to accommodate possible dimensional variations. They are classified as follows:

- **Structural joints**, which are those pertaining to the building structure. In this case, the joint must be left in the tiles coinciding with the joints in the structure or walls.
- **Perimeter joints**, those which should be left at the edges of tiled surfaces with other areas such as walls, pillars, steps, etc., to avoid the build-up of structural pressure. These should be continuous and greater than 5mm. They can be hidden by the skirting pieces, and must be filled with an elastic material up to the structural support.
- **Partition joints**, used to divide large areas covered with tiles, to avoid accumulations of contractions and dilatations. The maximum area that should be covered without these joints is 60m<sup>2</sup> for interior surfaces and half the area in exteriors. Partition joints should be no narrower than 5mm.

**GROUTING AND GROUTING MATERIALS.**

**GROUTING:**

It is not recommended to start grouting before the adhesive has completely hardened. A premature manipulation could disturb the positioning and adherence of the tiles.

Grouting is done with a rubber spatula or grouting trowel. The material should be pressed with back and forth movements to ensure that the joints are completely filled.

**GROUTING MATERIAL:**

Wide ranges of grouting materials for ceramic tiles exist, allowing selection of the most appropriate, depending on the type of tile and environment. Most of these materials contain cement and other components which have specific functions (whitening, mould resistance, smoothness of texture, hardness, flexibility...)

There are also other materials such as epoxies, organic materials and silicon-based, which do not contain cements, and far surpasses cement-based products when it comes to certain functions. Greater care and skill will be needed when using these products.

**Cement-based mortars:**

Containing hydraulic binders, mineral fillers and organic additives, these need only be mixed with water or another liquid just before their application. They may contain colouring agents in order to obtain colour variations. These mortars are divided into "normal" or "improved" categories according to their attributes (reduced water absorption, high scratch-resistance...) They are prepared by adding the amount of water indicated by the manufacturer to obtain a sufficiently thick and homogeneous paste. There are products on the market for both thick and thin joints. They can be applied to interior and exterior wall and floor coverings. They are compatible with all tile types. These grouts are not recommended for areas which undergo frequent cleaning with aggressive products, nor in industrial food plants (kitchens, slaughter houses...) or hygienic environments (operating rooms...).

**Reactive resin mortars:**

Made from synthetic resins (generally epoxies), organic additives and mineral fillers, these grouts harden caused by a chemical reaction. They are available in one or more components. They may contain pigments to provide colouring. The main characteristics of these products include their resistance to chemical products and bacteria, their high level of adherence, very good resistance to humidity, and excellent abrasion resistance. Their area of usage is that for areas where hygiene, chemical resistance, high scratch-resistance and excellent resistance to humidity are paramount.

TYPE	NAME
CG1	Material for normal cement joints.
CG2	Material for improved cement joints.
RG	Material for reaction resin joints.

**RECOMMENDATION**

When using coloured grouts, conduct a staining test on a loose tile prior to grouting your wall floor. Micronized "carbon black" grouts are not recommended.



**INSTALACIÓN Y MANTENIMIENTO**  
BALDOSA CERÁMICA

**USO Y MANTENIMIENTO**

Debido a sus características, los materiales cerámicos tienen una gran facilidad de uso y escasos requerimientos de mantenimiento, debido principalmente a su facilidad de limpieza.

Es importante, a la hora de elegir un producto cerámico, tener en cuenta los usos recomendados por el fabricante, el cual clasifica los materiales de acuerdo con sus propiedades físicas y químicas. Esta clasificación es adecuada siempre que se realice un uso de las baldosa cerámicas en condiciones normales, lo cual incluye: evitar abrasivos y/o golpes sobre la superficie de las piezas y evitar el contacto con productos que deterioren la superficie (como ácidos fluorhídricos). Es conveniente proteger los suelos de los materiales abrasivos interponiendo elementos de limpieza del calzado en la entrada de la vivienda, como alfombrillas o felpudos.

Para la limpieza inicial al finalizar la obra, los restos de cemento que aparecen en forma de película o pequeñas acumulaciones se pueden retirar de una forma muy sencilla con una solución ácida diluida (por ejemplo vinagre más agua). Sin embargo, nunca debe realizarse una limpieza ácida sobre baldosa recién colocadas, ya que el ácido reacciona con el cemento de las juntas. Es importante que tras la instalación y la limpieza inicial se protejan las zonas pavimentadas mediante cartón o film de plástico grueso con el fin de que las superficies no resulten dañadas por el resto de oficios hasta final de obra.

En general, el mantenimiento habitual consiste en la limpieza periódica mediante el lavado con agua o una solución diluida de detergente, siendo suficiente para devolver a los productos cerámicos su aspecto original.

Ocasionalmente pueden aparecer manchas o incrustaciones que no se eliminan con la limpieza habitual. En estos casos se debe usar un agente de limpieza y procedimientos específicos, dependiendo del tipo de revestimiento y características de la mancha. La aparición de daños en las baldosas suele producirse por el uso de productos de limpieza demasiado enérgicos o inadecuados para el tipo de superficie.

En la tabla siguiente se exponen algunos de los tipos de manchas más frecuentes y los productos recomendados para su tratamiento. De todos modos, recordar que es mejor probar previamente su efecto en una zona restringida y poco visible.

TIPO DE SUCIEDAD	PRODUCTO RECOMENDADO	PROVEEDOR
Cemento, lápiz, cal de agua, rayas de metales, óxidos.	DETERDEK	FILA
Residuos de juntas de epoxi.	CR10	FILA
Grasas, comidas, goma, tintes, rotulador, sangre, nicotina, orina, vomito, aceite, etc.	PS/87	FILA
Pintadas de grafitis, barniz, pintura, spray, acrílicos.	NO PAINT STAR	FILA
Café, té, zumos, refrescos.	SR/95	FILA
Cera de velas o de reparación de arañazos, resinas de árboles, residuos de cinta adhesiva.	FILASOLV	FILA
Silicona, pegamento.	ZERO SIL	FILA

**COLOCACIÓN & MANTENIMIENTO DE BALDOSAS CERÁMICAS CON RECUBRIMIENTO PVD**

**(Physical Vapor Deposition)**

Este producto debido a su fabricación puede presentar variaciones de calibre, textura, diseño y tono. Estas variaciones dan al producto una personalidad propia y unas características irrepetibles. Por todo ello, no se admitirán reclamaciones por estos motivos.

Para su colocación recomendamos que las piezas sean manipuladas con cuidado para evitar rayados. También que las piezas estén limpias y secas. Recomendamos emplear el adhesivo ELASTICER (FIXCER) o similares.

Hay que evitar que los restos de material de colocación endurezcan y queden adheridos a la superficie de las piezas. Para limpiar los restos de material de colocación antes de que hayan endurecido, usar una esponja y abundante agua.

En limpiezas sucesivas se recomienda la utilización de una bayeta suave húmeda y jabón neutro, evitando siempre el uso de detergentes enérgicos o productos y elementos de limpieza abrasivos, que podrían causar efectos irreversibles en las piezas.

Para cortar las piezas de vidrio, se recomienda emplear un cortador de disco refrigerado con agua.

**RECOMENDACIONES DE USO**  
BALDOSA CERÁMICA

Nuestros productos han sido concebidos para diferentes usos siendo clasificados mediante ensayos técnicos en seis grupos de acuerdo con su capacidad de resistencia a la abrasión, al desgaste, al ataque químico, etc.

LOS MODELOS PRODUCIDOS SON CONTROLADOS A TRAVÉS DE LOS ANÁLISIS EFECTUADOS EN LABORATORIOS EXTERNOS ACREDITADOS Y EN NUESTROS PROPIOS LABORATORIOS.

<b>A</b>	Baldosas esmaltadas de revestimiento. No recomendadas para suelos.
<b>B</b>	Para zonas de escaso tránsito con calzado suave, como baños y dormitorios privados, sin acceso directo desde el exterior. Debe evitarse toda abrasión.
<b>C</b>	Zonas de tránsito moderado, con calzado suave o normal. Por ejemplo todas las estancias de una vivienda privada a excepción de entradas y otras habitaciones que puedan ser objeto de un tránsito considerable.
<b>D</b>	Zonas de tránsito medio, con calzado normal. Aconsejados para todas las estancias de una vivienda privada (cocinas, vestíbulos, pasillos y terrazas), así como despachos, oficinas y lugares de uso similar. Resistencia media a la abrasión.
<b>E</b>	Para zonas de tránsito regular, como locales comerciales, hoteles, salas de exposición y tiendas. Resistencia relativamente fuerte a la abrasión.
	HIGH TRANSIT, pavimentos especialmente concebidos para uso de zonas de tránsito muy intenso. Altamente resistentes al desgaste.

**INSTALLATION AND MAINTENANCE**  
CERAMIC TILES

**USE AND MAINTENANCE**

Due to their properties, ceramic tiles are extremely easy to use and need very low maintenance as they are so easy to clean.

When selecting tiles, it is important to take note of the use recommended by the manufacturer, who will classify the material according to its physical and chemical properties. This classification is valid as long as the tiles are used under normal conditions which include: avoiding scratching tiles or blows to the pieces and not exposing the pieces to products which will deteriorate their surface (strong acids such as hydrofluoric acid). It is advisable to protect floors from abrasive materials, using some elements for the cleaning of shoe soles, like a doormat.

When tiling is completed, any traces of cement can be successfully removed with a diluted acid solution (for example vinegar). However, an acid wash of any type should not be carried out on newly laid tiles as the acid will react with the cement. After installation and initial cleaning, it is important to protect the area with cardboard or thick plastic film, in order to avoid the tiles to be damaged by the rest of works to be made until construction is finished.

In general, maintenance consists in a periodical cleaning of the tiles with either water or a mild detergent diluted in water. This should be enough to return the tiles to their original conditions.

Occasionally, some colouring products can cause stains or incrustations which cannot be removed with normal cleaning. In these cases, specific cleaning agents and procedures should be used according to the type of tile and the nature of the stain. Damage to tiles is usually caused by over-aggressive cleaning products or products which are not suited to the type of tile. As a general rule, before using a cleaning product over the whole surface, carry out a test on a small, hidden area.

The following table shows some of the most frequent stain types, and the recommended products for their cleanind. Remember to always test a small patch of floor with the cleaning product before proceeding to larger, more visible areas.

TYPE OF DIRT	RECOMMENDED PRODUCT	SUPPLIER
Cement, pencil, lime water, metal scratches, oxides.	DETERDEK	FILA
Waste from epoxy connections.	CR10	FILA
Fats, foods, rubber, dyes, marker, blood, nicotine, urine, vomit, oil, etc.	PS/87	FILA
Painted graffiti, varnish, paint, spray, acrylics.	NO PAINT STAR	FILA
Coffee, tea, juice, soft drinks.	SR/95	FILA
Candle wax or scratch repair, tree resins, adhesive tape residue.	FILASOLV	FILA
Silicone, glue.	ZERO SIL	FILA

**PLACEMENT & MAINTENANCE OF CERAMIC TILES WITH PVD COATING**

**(Physical Vapour Deposition)**

Due to its manufacture, this product can present variations of calibre, texture, design, and tone. These variations give the product its own personality and unreproducible characteristics. Therefore, no claims will be accepted for these reasons.

For its placement, we recommend that the pieces be handled with care to avoid scratches. Also that the pieces remain clean and dry. We recommend using ELASTICER adhesive (FIXCER) or a similar product.

It is necessary to avoid that the remains of placement material harden and remain adhered to the surface of the pieces. To clean the remains of placement material before they have hardened, use a sponge and plenty of water.

In future cleanings, the use of a soft, damp cloth and neutral soap is recommended, avoiding the use of energetic detergents or abrasive cleaning products and elements, which could cause irreversible effects on the pieces.

To cut glass pieces, it is recommended to use a water-cooled cutting disc.

**RECOMMENDED USE**  
CERAMIC TILES:







Our products have been designed for different uses and, after technical tests, they have been divided into six groups, depending on their resistance to chemical products, abrasion, etc.

THE RESULTS OF THESE TESTS HAVE BEEN ESPECIFIED IN EACH ONE OF THE MODELS AND HAVE BEEN OBTAINED ACCORDING TO THE ANALYSIS CARRIED OUT BY THE EXTERNAL LABORATORIES AND BY OUR OWN LABORATORIES.















<b>A</b>	Glazed wall tiles. Not recommended for floors.
<b>B</b>	For light transit areas with soft soled footwear, such as private bathrooms and bedrooms without direct access to the outside. Any abrasion should be avoided.
<b>C</b>	For medium transit areas with soft soled or normal footwear, for example, rooms in the living areas of a home with the exception of entrances, and other rooms that may have a lot of traffic.
<b>D</b>	For medium transit areas with normal footwear. Recommended for all areas of private home (kitchens, entrances, corridors and terraces), as well as offices, consulting rooms and other places of similar use. Medium resistance to abrasion.
<b>E</b>	For areas of regular transit, such as commercial zones, hotels, exhibition rooms and shops. Fairly high resistance to abrasion.
	HIGH TRANSIT, floor tiles especially designed for areas of heavy transit. Highly resistant to wear.



PROPIEDADES FÍSICO-QUÍMICAS | PHYSICAL AND CHEMICAL PROPERTIES  
REVESTIMIENTO | WALL TILES

CARACTERÍSTICAS TÉCNICAS TECHNICAL FEATURES	MÉTODO DE LA NORMA STANDARD TEST METHOD	VALOR NORMA REQUIREMENT	REVESTIMIENTO WALL TILES
 RESISTENCIA A LA HELADA FROST RESISTANCE	ISO 10545-12	---	---
 RESISTENCIA A LA ROTURA BREAKING STRENGTH	ISO 10545-4	≥ 600 N	CUMPLE PASSES
 RESISTENCIA A LA FLEXIÓN MODULUS OF RUPTURE	ISO 10545-4	≥ 12 N / mm <sup>2</sup>	CUMPLE PASSES
 RESISTENCIA AL ATAQUE QUÍMICO CHEMICAL RESISTANCE	ISO 10545-13 Resistencia a ácidos y bases de baja concentración. <i>Resistance to low concentrations of acids and bases.</i>	VALOR DECLARADO DECLARED VALUE	SEGÚN MODELO ACCORDING TO MODEL
	ISO 10545-13 Resistencia a ácidos y álcalis de alta concentración. <i>Resistance to high concentrations of acids and bases.</i>	VALOR DECLARADO DECLARED VALUE	SEGÚN MODELO ACCORDING TO MODEL
	ISO 10545-13 Resistencia a productos domésticos y sales para piscinas. <i>Resistance to cleaning products and swimmingpool aditives.</i>	MÍNIMO CLASE B MINIMUM CLASS B	CUMPLE PASSES
 RESISTENCIA A LAS MANCHAS STAIN RESISTANCE	ISO 10545-14	MÍNIMO CLASE 3 MINIMUM CLASS 3	CUMPLE PASSES
 ABSORCIÓN DE AGUA (E) WATER ABSORTION (E)	ISO 10545-3	E > 10%	CUMPLE PASSES

PROPIEDADES FÍSICO-QUÍMICAS | PHYSICAL AND CHEMICAL PROPERTIES  
GRES PORCELÁNICO | PORCELAIN TILES

CARACTERÍSTICAS TÉCNICAS TECHNICAL FEATURES	MÉTODO DE LA NORMA STANDARD TEST METHOD	VALOR NORMA REQUIREMENT	GRES PORCELÁNICO PORCELAIN TILES
 RESISTENCIA A LA HELADA FROST RESISTANCE	ISO 10545-12	RESISTENTE RESISTANT	CUMPLE PASSES
 RESISTENCIA A LA ROTURA BREAKING STRENGTH	ISO 10545-4	≥ 1300 N	CUMPLE PASSES
 RESISTENCIA A LA FLEXIÓN MODULUS OF RUPTURE	ISO 10545-4	≥ 35 N / mm <sup>2</sup>	CUMPLE PASSES
 RESISTENCIA AL RAYADO (MOHS) SCRATCH RESISTANCE (MOHS)	UNE EN-101	VALOR DECLARADO DECLARED VALUE	SEGÚN MODELO ACCORDING TO MODEL
	UNE-41901	VALOR DECLARADO DECLARED VALUE	 SEGÚN MODELO ACCORDING TO MODEL
 RESISTENCIA AL DESLIZAMIENTO SLIP RESISTANCE	DIN 51130	VALOR DECLARADO DECLARED VALUE	 SEGÚN MODELO ACCORDING TO MODEL
	BS 7976-2:2002 +A1:2013	H 0-24 M 25-35 L 36+	 SEGÚN MODELO ACCORDING TO MODEL
	ANSI A 137.1 (DCOF)	< 0,42 ≥ 0,42	 SEGÚN MODELO ACCORDING TO MODEL
 RESISTENCIA AL DESLIZAMIENTO SLIP RESISTANCE	DIN 51097	A: > 12° A+B: > 18° A+B+C: > 24°	SEGÚN MODELO ACCORDING TO MODEL
 RESISTENCIA AL ATAQUE QUÍMICO CHEMICAL RESISTANCE	ISO 10545-13 Resistencia a ácidos y bases de baja concentración. <i>Resistance to low concentrations of acids and bases.</i>	VALOR DECLARADO DECLARED VALUE	SEGÚN MODELO ACCORDING TO MODEL
	ISO 10545-13 Resistencia a ácidos y álcalis de alta concentración. <i>Resistance to high concentrations of acids and bases.</i>	VALOR DECLARADO DECLARED VALUE	SEGÚN MODELO ACCORDING TO MODEL
	ISO 10545-13 Resistencia a productos domésticos y sales para piscinas. <i>Resistance to cleaning products and swimmingpool aditives.</i>	MÍNIMO CLASE B MINIMUM CLASS B	CUMPLE PASSES
 RESISTENCIA A LAS MANCHAS STAIN RESISTANCE	ISO 10545-14	MÍNIMO CLASE 3 MINIMUM CLASS 3	CUMPLE PASSES
 ABSORCIÓN DE AGUA (E) WATER ABSORTION (E)	ISO 10545-3	E ≤ 0,5%	CUMPLE PASSES
 RESISTENCIA A LA ABRASIÓN ABRASION RESISTANCE	ISO 10545-7	VALOR DECLARADO DECLARED VALUE	SEGÚN MODELO ACCORDING TO MODEL



LISTA DE EMBALAJE | PACKING LIST



PASTA BLANCA | WHITE BODY

Unidad mínima de venta: 1 caja | Minimum sales unit: 1 box

FORMATO (cm) SIZE (inches)	PZAS/CAJA PIECES/BOX	M2/CAJA (APROX.) SQ.M/BOX (APROX.)	KG/CAJA (APROX.) KG/BOX (APROX.)	CAJAS/PALET BOX/PALLET	CAJAS/EUR.PALET BOX/EUR.PALLET	M2/PALET SQ.M/PALLET	M2/EUR.PALET SQ.M/EUR.PALLET
40x120 cm · 15,7"x47,2"	3	1,44	29,07	24	---	34,56	---
30x90 cm · 11,8"x35,4"	4	1,08	19,45	54	45	58,32	48,60
30x60 cm · 11,8"x23,6"	6	1,08	19,23	60	60	64,80	64,80

DECORADOS PASTA BLANCA | WHITE BODY DECORATION

Unidad mínima de venta: 1 pieza | Minimum sales unit: 1 piece

FORMATO (cm) SIZE (inches)	PZAS/CAJA PIECES/BOX	M2/CAJA (APROX.) SQ.M/BOX (APROX.)	KG/CAJA (APROX.) KG/BOX (APROX.)	CAJAS/PALET BOX/PALLET	CAJAS/EUR.PALET BOX/EUR.PALLET	M2/PALET SQ.M/PALLET	M2/EUR.PALET SQ.M/EUR.PALLET
40x120 cm · 15,7"x47,2"	2	0,96	19,42	26	---	24,96	---
30x90 cm · 11,8"x35,4"	4	1,08	19,71	18	12	19,44	12,96
9,3x90 cm · 3,7"x35,4"	12	1,00	15,03	---	32	---	32,00



PORCELÁNICO | PORCELAIN

Unidad mínima de venta: 1 caja | Minimum sales unit: 1 box

FORMATO (cm) SIZE (inches)	PZAS/CAJA PIECES/BOX	M2/CAJA (APROX.) SQ.M/BOX (APROX.)	KG/CAJA (APROX.) KG/BOX (APROX.)	CAJAS/PALET BOX/PALLET	CAJAS/EUR.PALET BOX/EUR.PALLET	M2/PALET SQ.M/PALLET	M2/EUR.PALET SQ.M/EUR.PALLET
120x120 cm · 47,2"x47,2"	1	1,44	31,00	40	---	57,60	---
90x90 cm · 35,4"x35,4"	2	1,62	38,40	24	---	38,88	---
60x120 cm · 23,6"x47,2"	2	1,44	32,88	---	30	---	43,20
30x120 cm · 11,8"x47,2"	4	1,44	35,20	---	30	---	43,20
19,4x120 cm · 7,6"x47,2"	6	1,40	35,02	30	---	42,00	---
60x60 cm · 23,6"x23,6"	3	1,08	23,81	48	40	51,84	43,20
30x60 cm · 11,8"x23,6"	6	1,08	24,13	48	60	51,84	64,80
14,7x60 cm · 5,8"x23,6"	10	0,88	20,56	---	48	---	42,24
52x60 cm · 20,5"x23,6" · HEX60	4	0,94	19,31	36	---	33,84	---

DECORADOS PORCELÁNICO | PORCELAIN DECORATION

Unidad mínima de venta: 1 pieza | Minimum sales unit: 1 piece

FORMATO (cm) SIZE (inches)	PZAS/CAJA PIECES/BOX	M2/CAJA (APROX.) SQ.M/BOX (APROX.)	KG/CAJA (APROX.) KG/BOX (APROX.)	CAJAS/PALET BOX/PALLET	CAJAS/EUR.PALET BOX/EUR.PALLET	M2/PALET SQ.M/PALLET	M2/EUR.PALET SQ.M/EUR.PALLET
60x120 cm · 23,6"x47,2"	2	1,44	32,88	---	21	---	30,24
60x60 cm · 23,6"x23,6"	3	1,08	23,81	48	40	51,84	43,20
30x60 cm · 11,8"x23,6"	6	1,08	24,13	48	60	51,84	64,80

LISTA DE EMBALAJE | PACKING LIST

MOSAICOS | MOSAICS

Unidad mínima de venta: 1 pieza | Minimum sales unit: 1 piece

FORMATO (cm) SIZE (inches)	PZAS/CAJA PIECES/BOX	M2/CAJA (APROX.) SQ.M/BOX (APROX.)	KG/CAJA (APROX.) KG/BOX (APROX.)	CAJAS/PALET BOX/PALLET	CAJAS/EUR.PALET BOX/EUR.PALLET	M2/PALET SQ.M/PALLET	M2/EUR.PALET SQ.M/EUR.PALLET
<b>MOSAICO 30 · 30 MOSAIC</b>							
30x30 cm · 11,8"x11,8"	5	0,45	9,40	108	84	48,60	37,80
<b>MOSAICO BRICK · BRICK MOSAIC</b>							
25x25 cm · 9,8"x9,8"	6	0,38	9,00	---	108	---	40,50
<b>MOSAICO CROSS · CROSS MOSAIC</b>							
30x30 cm · 11,8"x11,8"	5	0,45	9,40	108	84	48,60	37,80
<b>MOSAICO DIAMOND · DIAMOND MOSAIC</b>							
24,7x22,6 cm · 9,7"x8,9"	5	0,28	5,28	108	84	30,24	23,52
<b>MOSAICO HEX · HEX MOSAIC</b>							
29,7x34,5 cm · 11,7"x13,6"	6	0,61	11,00	---	54	---	33,20
<b>MOSAICO HEX · HEX MOSAIC</b>							
27,5x29,3 cm · 10,8"x11,5"	4	0,30	6,90	---	84	---	25,20
<b>MOSAICO I · I MOSAIC</b>							
30x30 cm · 11,8"x11,8"	5	0,45	9,19	108	84	48,60	37,80
<b>MOSAICO M · M MOSAIC</b>							
24,5x27,8 cm · 9,6"x10,9"	5	0,34	7,85	108	84	36,72	28,56
<b>MOSAICO MURETTO · MURETTO MOSAIC</b>							
29,8x26,2 cm · 11,7"x10,3"	5	0,39	9,45	90	84	35,10	32,76
<b>MOSAICO LEAF · LEAF MOSAIC</b>							
28,4x29,5 cm · 11,2"x11,6"	5	0,42	9,00	72	---	30,24	---
<b>MOSAICO PICKET · PICKET MOSAIC</b>							
27,4x29,8 cm · 10,8"x11,7"	5	0,41	8,47	108	---	44,28	---
<b>MOSAICO T5 · T5 MOSAIC</b>							
30x30 cm · 11,8"x11,8"	5	0,45	9,40	108	84	48,60	37,80
<b>MOSAICO V · V MOSAIC</b>							
21,6x28 cm · 8,5"x11"	5	0,30	6,64	108	---	32,40	---
<b>SLATS 120 · 120 SLATS</b>							
18,5x120 cm · 7,3"x47,2"	6	1,33	35,02	---	30	---	39,90

RODAPIÉS PORCELÁNICO | PORCELAIN SKIRTINGS

Unidad mínima de venta: 1 caja | Minimum sales unit: 1 box



RODAPIÉ | SKIRTING

	NATURAL	LAPADO y SCINTILLANTE LAPATTO and SCINTILLANTE	LAPADO METALIZADO METALLIC LAPATTO	FORMATO (cm) SIZE (inches)	PZAS/CAJA PIECES/BOX	KG/CAJA (APROX.) KG/BOX (APROX.)	CAJAS/PALET BOX/PALLET	CAJAS/EUR.PALET BOX/EUR.PALLET
		P50	P46					
RODAPIÉ   SKIRTING R 120	P50	P46	P44	10x120 cm · 3,9"x47,2"	5	15,10	-	60
RODAPIÉ   SKIRTING R 90	P76	P73	P58	8,8x90 cm · 3,5"x35,4"	11	19,30	40	30
RODAPIÉ   SKIRTING R 60	P80	---	---	10x60 cm · 3,9"x23,6"	14	21,15	48	32
RODAPIÉ   SKIRTING R 60	P29	P27	P26	8x60 cm · 3,1"x23,6"	20	18,50	64	56



## LISTA DE EMBALAJE | PACKING LIST

### PELDAÑOS PORCELÁNICO GS | GS PORCELAIN STEPS

Unidad mínima de venta: 1 pieza | *Minimum sales unit: 1 piece*

	NATURAL y DRY	LAPADO y SCINTILLANTE LAPATTO and SCINTILLANTE	LAPADO METALIZADO METALLIC LAPATTO	FORMATO (cm) SIZE (inches)	PZAS/CAJA PIECES/BOX	KG/CAJA (APROX.) KG/BOX (APROX.)
PELDAÑO   STEP EXT 33x120	P39	---	---	33x120 cm · 13"x47,2"	2	25,90
PELDAÑO   STEP GS 120	P43	P41	P42	33x120 cm · 13"x47,2"	2	23,04
PELDAÑO   STEP GSDI-GSDD 120	P72	P57	P37	33x120 cm · 13"x47,2"	1	12,15
PELDAÑO   STEP GS 90	P20	P22	P23	33x90 cm · 13"x35,4"	2	16,67
PELDAÑO   STEP GSDI-GSDD 90	P81	P77	P78	33x90 cm · 13"x35,4"	1	8,98
PELDAÑO   STEP GS 60	P59	P51	P49	33x60 cm · 13"x23,6"	2	10,61
PELDAÑO   STEP GSDI-GSDD 60	P69	P68	P47	33x60 cm · 13"x23,6"	1	5,94

PELDAÑO | STEP GS

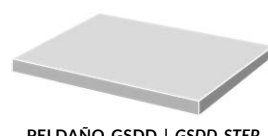
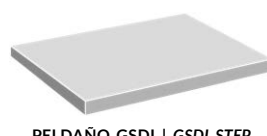
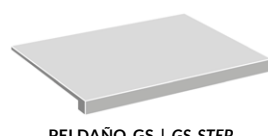
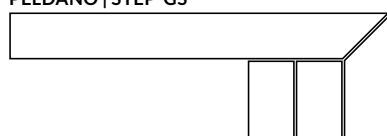

PELDAÑO | STEP EXT

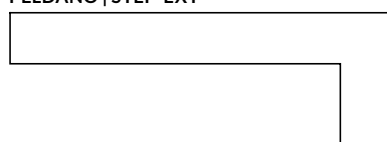

PELDAÑOS GX, FS y LS consultar tarifa de precios y packing al departamento comercial · [comercial@azteca.es](mailto:comercial@azteca.es).  
GX, FS and LS STEPS please consult Sales Department for prices and packing · [comercial@azteca.es](mailto:comercial@azteca.es).

PELDAÑO | STEP GX

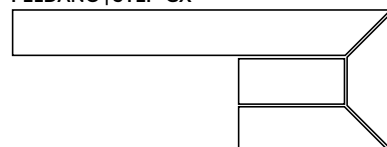

PELDAÑO | STEP FS

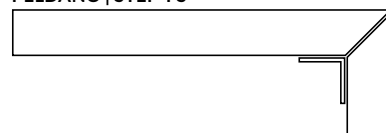

PELDAÑO | STEP LS

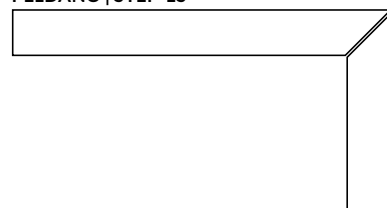

## LISTA DE EMBALAJE | PACKING LIST



### PASTA BLANCA | WHITE BODY

Unidad mínima de venta: 1 caja | *Minimum sales unit: 1 box*

	FORMATO (cm) SIZE (inches)	PZAS/CAJA PIECES/BOX	M2/CAJA (APROX.) SQ.M/BOX (APROX.)	KG/CAJA (APROX.) KG/BOX (APROX.)	CAJAS/PALET BOX/PALLET	CAJAS/EUR.PALET BOX/EUR.PALLET	M2/PALET SQ.M/PALLET	M2/EUR.PALET SQ.M/EUR.PALLET
	5x25 cm · 2"x9,8"	48	0,57	10,00	---	96	---	54,96
	6,2x25 cm · 2,4"x9,8"	29	0,45	6,00	---	120	---	53,94
	5x50 cm · 2"x19,7"	26	0,62	11,00	---	88	---	54,86



### PORCELÁNICO | PORCELAIN

Unidad mínima de venta: 1 caja | *Minimum sales unit: 1 box*

	FORMATO (cm) SIZE (inches)	PZAS/CAJA PIECES/BOX	M2/CAJA (APROX.) SQ.M/BOX (APROX.)	KG/CAJA (APROX.) KG/BOX (APROX.)	CAJAS/PALET BOX/PALLET	CAJAS/EUR.PALET BOX/EUR.PALLET	M2/PALET SQ.M/PALLET	M2/EUR.PALET SQ.M/EUR.PALLET
	5x15 cm · 2"x5,9"	108	0,81	14,00	---	76	---	61,56
	15x15 cm · 5,9"x5,9"	44	1,00	17,00	64	---	64,00	---
	20x20 cm · 7,9"x7,9"	15	0,60	11,50	---	116	---	69,60



## DESCRIPCIÓN DE ICONOS | ICONS DESCRIPTION

	<b>Antihielo.</b> No frost.		<b>Piezas con acabado mate.</b> Matt-finishing tiles.
	<b>Piezas realizadas en pasta blanca.</b> White body tiles.		<b>Piezas con acabado satinado.</b> Satin-finishing tiles.
	<b>Piezas realizadas en pasta roja.</b> Red body tiles.		<b>Piezas con acabado brillante.</b> Bright-finishing tiles.
	<b>Piezas realizadas en porcelánico.</b> Porcelain tiles.		<b>Piezas con acabado "lapatto" brillo.</b> Glossy "Lapatto" finishing tiles.
	<b>Piezas rectificadas.</b> Rectified tiles.		<b>Piezas con acabado "lapatto" mate.</b> Matt "Lapatto" finishing tiles.
	<b>Piezas no rectificadas.</b> Non rectified tiles.		<b>Piezas con acabado scintillante.</b> Scintillante finishing tiles.
	<b>Efecto uniforme del tono.</b> Homogeneous shading effect.		<b>Piezas con efectos digitales.</b> Digital effects finishing tiles.
	<b>Bajo efecto destonificado.</b> Slight shade variation.		<b>Piezas con efectos digitales.</b> Digital effects finishing tiles.
	<b>Medio efecto destonificado.</b> Moderate shade variation.		<b>Tecnología digital usada para casar el diseño y el relieve de cada una de las piezas.</b> Digital technology used to match the pattern and the structure of every single piece.
	<b>Alto efecto destonificado.</b> Substantial shade variation.		<b>Piezas divisibles.</b> Suited to be divided into pieces.
	<b>Piezas aptas para colocación sólo en pared.</b> Tiles suitable for laying only on walls.		<b>Resistencia al deslizamiento.</b> Slip resistance.
	<b>Piezas aptas para colocación tanto en pared como en suelo.</b> Tiles suitable for laying on wall and floor.		<b>Resistencia al deslizamiento.</b> Slip resistance.
	<b>Piezas aptas para colocación sólo en suelo.</b> Tiles suitable for laying only on floor.		<b>Recomendable seguir la indicación durante su colocación.</b> It is recommended to follow the indication during collocation.
	<b>Piezas con volumen.</b> Voluminous.		<b>Recomendable no dejar una junta inferior a 1,5 mm.</b> Recommended to use a joint of not less than 1,5 mm.
	<b>Piezas con soporte coloreado.</b> Color body.		<b>Se aconseja que la colocación a rompejunta no supere el 20% del lado sobre el que se aplica.</b> We recommend that discontinuous laying does not exceed 20% of the side to which it is applied.
	<b>Piezas de metal o que contienen metal.</b> Made of metal or containing metal.		<b>Se recomienda el uso de sistemas nivelados para garantizar una correcta colocación.</b> We recommend the use of levelled systems in order to guarantee a proper arrangement.

## EXPOSITORES | DISPLAYS

### APOLO



#### DIMENSIONES - MEASURES:

Anchura - Width: 300 cm | Altura - Height: 230 cm | Fondo - Depth: 85-112 cm

ACABADO - FINISH: Plata + Antracita | Silver + Antracite

ILUMINACIÓN - LIGHTING: SI - YES

CAPACIDAD - CAPACITY: 24 PANELES - PANELS

DIMENSIONES DEL PANEL - PANEL MEASURES:

Anchura - Width: 100,5 cm | Altura - Height: 192,5 cm

EMBALAJE - PACKAGING: 1 BULTO | 1 PACKAGE

PESO - WEIGHT: 430 kg

DIMENSIONES DEL EMBALAJE - PACKAGING MEASURES:

Anchura - Width: 305 cm | Altura - Height: 110 cm | Fondo - Depth: 95 cm

### EGEO



#### DIMENSIONES - MEASURES:

Anchura - Width: 320 cm | Altura - Height: 220 cm | Fondo - Depth: 110-156 cm

ACABADO - FINISH: Plata + Grafito | Silver + Graphite

ILUMINACIÓN - LIGHTING: SI - YES

CAPACIDAD - CAPACITY: 24 + 2 PANELES - PANELS

DIMENSIONES DEL PANEL - PANEL MEASURES:

Anchura - Width: 100,5 cm | Altura - Height: 192,5 cm

EMBALAJE - PACKAGING: 1 BULTO | 1 PACKAGE

PESO - WEIGHT: 465 kg

DIMENSIONES DEL EMBALAJE - PACKAGING MEASURES:

Anchura - Width: 229 cm | Altura - Height: 140 cm | Fondo - Depth: 121 cm

### ANKARA



#### DIMENSIONES - MEASURES:

Anchura - Width: 315 cm | Altura - Height: 234 cm | Fondo - Depth: 104-158 cm

ACABADO - FINISH: Plata + Grafito | Silver + Graphite

ILUMINACIÓN - LIGHTING: SI - YES

CAPACIDAD - CAPACITY: 24 + 2 PANELES - PANELS

DIMENSIONES DEL PANEL - PANEL MEASURES:

Anchura - Width: 100,5 cm | Altura - Height: 192,5 cm

EMBALAJE - PACKAGING: 1 BULTO | 1 PACKAGE

PESO - WEIGHT: 435 kg

DIMENSIONES DEL EMBALAJE - PACKAGING MEASURES:

Anchura - Width: 229 cm | Altura - Height: 119 cm | Fondo - Depth: 118 cm

### BOOK CORNER 26P



#### DIMENSIONES - MEASURES:

Anchura - Width: 356 cm | Altura - Height: 225 cm | Fondo - Depth: 117-170 cm

ACABADO - FINISH: Plata + Grafito | Silver + Graphite

ILUMINACIÓN - LIGHTING: SI - YES

CAPACIDAD - CAPACITY: 24 + 2 PANELES - PANELS

DIMENSIONES DEL PANEL - PANEL MEASURES:

Anchura - Width: 100,5 cm | Altura - Height: 192,5 cm

EMBALAJE - PACKAGING: 1 BULTO | 1 PACKAGE

PESO - WEIGHT: 500 kg

DIMENSIONES DEL EMBALAJE - PACKAGING MEASURES:

Anchura - Width: 224 cm | Altura - Height: 110 cm | Fondo - Depth: 124 cm



EXPOSITORES | DISPLAYS

DETROIT SIMPLE



DIMENSIONES - MEASURES:

Anchura - Width: 228 cm | Altura - Height: 230 cm | Fondo - Depth: 117 cm

ACABADO - FINISH: Plata + Grafito | Silver + Graphite

ILUMINACIÓN - LIGHTING: SI - YES

CAPACIDAD - CAPACITY: 15 + 2 PANELES - PANELS

DIMENSIONES DEL PANEL - PANEL MEASURES:

Anchura - Width: 100,5 cm | Altura - Height: 192,5 cm

EMBALAJE - PACKAGING: 1 BULTO | 1 PACKAGE

PESO - WEIGHT: 510 kg

DIMENSIONES DEL EMBALAJE - PACKAGING MEASURES:

Anchura - Width: 230 cm | Altura - Height: 115 cm | Fondo - Depth: 120 cm

DAKAR DOBLE



DIMENSIONES - MEASURES:

Anchura - Width: 341 cm | Altura - Height: 230 cm | Fondo - Depth: 99 cm

ACABADO - FINISH: Plata + Antracita | Silver + Antracite

ILUMINACIÓN - LIGHTING: SI - YES (LED)

CAPACIDAD - CAPACITY: 24 + 3 PANELES - PANELS

DIMENSIONES DEL PANEL - PANEL MEASURES:

Anchura - Width: 100,5 cm | Altura - Height: 192,5 cm

EMBALAJE - PACKAGING: 2 BULTOS | 2 PACKAGES

PESO - WEIGHT: 1 - 455 kg | 2 - 440 kg

DIMENSIONES DEL EMBALAJE - PACKAGING MEASURES:

1- Anchura - Width: 346 cm | Altura - Height: 54 cm | Fondo - Depth: 121 cm  
2- Anchura - Width: 216 cm | Altura - Height: 96 cm | Fondo - Depth: 108 cm

EXPOSITORES | DISPLAYS

EXTRAIBLE 10P



DIMENSIONES - MEASURES:

Anchura - Width: 65 cm | Altura - Height: 225 cm | Fondo - Depth: 141 cm

ACABADO - FINISH: Plata + Antracita | Silver + Antracite

ILUMINACIÓN - LIGHTING: NO - NOT

CAPACIDAD - CAPACITY: 10 PANELES - PANELS

DIMENSIONES DEL PANEL - PANEL MEASURES:

Anchura - Width: 100,5 cm | Altura - Height: 192,5 cm

EMBALAJE - PACKAGING: 1 BULTO | 1 PACKAGE

PESO - WEIGHT: 350 kg

DIMENSIONES DEL EMBALAJE - PACKAGING MEASURES:

Anchura - Width: 229 cm | Altura - Height: 156 cm | Fondo - Depth: 71 cm

EXTRAIBLE 20P



DIMENSIONES - MEASURES:

Anchura - Width: 118 cm | Altura - Height: 225 cm | Fondo - Depth: 141 cm

ACABADO - FINISH: Plata + Antracita | Silver + Antracite

ILUMINACIÓN - LIGHTING: NO - NOT

CAPACIDAD - CAPACITY: 20 PANELES - PANELS

DIMENSIONES DEL PANEL - PANEL MEASURES:

Anchura - Width: 100,5 cm | Altura - Height: 192,5 cm

EMBALAJE - PACKAGING: 1 BULTO | 1 PACKAGE

PESO - WEIGHT: 480 kg

DIMENSIONES DEL EMBALAJE - PACKAGING MEASURES:

Anchura - Width: 229 cm | Altura - Height: 156 cm | Fondo - Depth: 122 cm

SELLA 17



DIMENSIONES - MEASURES:

Anchura - Width: 245 cm | Altura - Height: 212 cm | Fondo - Depth: 130 cm

ACABADO - FINISH: Plata | Silver

ILUMINACIÓN - LIGHTING: OPCIONAL - OPTIONAL

CAPACIDAD - CAPACITY: 17 PANELES - PANELS

DIMENSIONES DEL PANEL - PANEL MEASURES:

Anchura - Width: 100,5 cm | Altura - Height: 192,5 cm

EMBALAJE - PACKAGING: 1 BULTO | 1 PACKAGE

PESO - WEIGHT: 480 kg

DIMENSIONES DEL EMBALAJE - PACKAGING MEASURES:

Anchura - Width: 220 cm | Altura - Height: 100 cm | Fondo - Depth: 139 cm

TIBER 33



DIMENSIONES - MEASURES:

Anchura - Width: 339 cm | Altura - Height: 219 cm | Fondo - Depth: 126 cm

ACABADO - FINISH: Plata | Silver

ILUMINACIÓN - LIGHTING: OPCIONAL - OPTIONAL

CAPACIDAD - CAPACITY: 33 PANELES - PANELS

DIMENSIONES DEL PANEL - PANEL MEASURES:

Anchura - Width: 100,5 cm | Altura - Height: 192,5 cm

EMBALAJE - PACKAGING: 1 BULTO | 1 PACKAGE

PESO - WEIGHT: 725 kg

DIMENSIONES DEL EMBALAJE - PACKAGING MEASURES:

Anchura - Width: 229 cm | Altura - Height: 130 cm | Fondo - Depth: 144 cm

CAJONERA SIMPLE

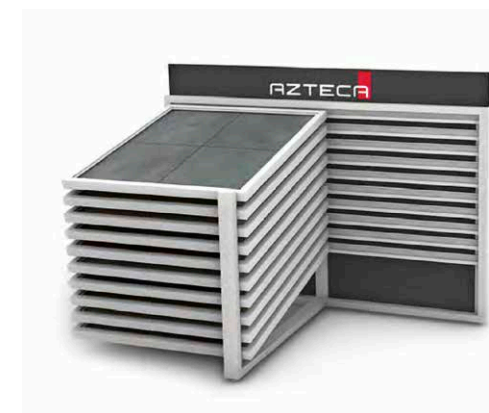

DIMENSIONES - MEASURES:

A- Anchura - Width: 213 cm | Altura - Height: 140 cm | Fondo - Depth: 113 cm

B- Anchura - Width: 258 cm | Altura - Height: 140 cm | Fondo - Depth: 133 cm

ACABADO - FINISH: Plata + Antracita | Silver + Antracite

ILUMINACIÓN - LIGHTING: NO - NOT

CAPACIDAD - CAPACITY: 10 PANELES - PANELS

DIMENSIONES DEL PANEL - PANEL MEASURES:

Anchura - Width: A-101 cm B-121 cm | Altura - Height: A-101 cm B-121 cm

EMBALAJE - PACKAGING: 1 BULTO | 1 PACKAGE

PESO - WEIGHT: A-400 Kg B-450 Kg

DIMENSIONES DEL EMBALAJE - PACKAGING MEASURES:

A- Anchura - Width: 219 cm | Altura - Height: 80 cm | Fondo - Depth: 147 cm

B- Anchura - Width: 260 cm | Altura - Height: 80 cm | Fondo - Depth: 147 cm

CAJONERA DOBLE



DIMENSIONES - MEASURES:

A- Anchura - Width: 318 cm | Altura - Height: 140 cm | Fondo - Depth: 113 cm

B- Anchura - Width: 324 cm | Altura - Height: 140 cm | Fondo - Depth: 133 cm

ACABADO - FINISH: Plata + Antracita | Silver + Antracite

ILUMINACIÓN - LIGHTING: NO - NOT

CAPACIDAD - CAPACITY: 20 PANELES - PANELS

DIMENSIONES DEL PANEL - PANEL MEASURES:

Anchura - Width: A-101 cm B-121 cm | Altura - Height: A-101 cm B-121 cm

EMBALAJE - PACKAGING: 1 BULTO | 1 PACKAGE

PESO - WEIGHT: A-600 Kg B-700 Kg

DIMENSIONES DEL EMBALAJE - PACKAGING MEASURES:

A- Anchura - Width: 324 cm | Altura - Height: 80 cm | Fondo - Depth: 147 cm

B- Anchura - Width: 384 cm | Altura - Height: 80 cm | Fondo - Depth: 147 cm



OTROS EXPOSITORES | OTHER DISPLAYS



DIMENSIONES - MEASURES:  
Anchura - Width: 22 cm  
Altura - Height: 31,5 cm  
Fondo - Depth: 2,5 cm  
ACABADO - FINISH: Mate - Matt

CAPACIDAD - CAPACITY: 9-12 Piezas - Pieces  
DIMENSIONES DE LA PIEZA - PIECE MEASURES:  
Varios formatos | Several formats

DIMENSIONES DEL EMBALAJE - PACKAGING MEASURES:  
Anchura - Width: 22 cm  
Altura - Height: 31,5 cm  
Fondo - Depth: 2,5 cm  
PESO - WEIGHT:  
Según colección | Depending on collection

CARPETA TÉCNICA (DÍPTICO)

COLECCIONES - COLLECTIONS:

AKILA, ELEKTRA, HARLEY, MOONLIGHT, PASSION, STONEAGE, SYNTHESIS.



DIMENSIONES - MEASURES:  
Anchura - Width: 34,5 cm  
Altura - Height: 34,5 cm  
Fondo - Depth: 2,8 cm  
ACABADO - FINISH: Mate - Matt

CAPACIDAD - CAPACITY: 1-8 Piezas - Pieces  
DIMENSIONES DE LA PIEZA - PIECE MEASURES:  
Varios formatos | Several formats

DIMENSIONES DEL EMBALAJE - PACKAGING MEASURES:  
Anchura - Width: 34,5 cm  
Altura - Height: 34,5 cm  
Fondo - Depth: 2,8 cm  
PESO - WEIGHT:  
Según colección | Depending on collection

CARPETA TÉCNICA (ESTÁNDAR)

COLECCIONES - COLLECTIONS:

ANETO, BALI, BARRICA, BELLVER, CALACATTA, CEMENT, CERVINO, DENVER, DUBAI, HERITAGE, KAI, MACCHIA VECCHIA, ONYX, ORION, SAN FRANCISCO, SENSE, SHELLSTONE, STONECRETE (DISTRICT-STREET), STUDIO, TRAVERTINE (LACIO-TIVOLI), VINCENT STONE, VULCANO.



DIMENSIONES - MEASURES:  
Anchura - Width: 24,5 cm  
Altura - Height: 20 cm  
Fondo - Depth: 0,15 cm  
ACABADO - FINISH: Mate - Matt

CAPACIDAD - CAPACITY: ---  
DIMENSIONES DE LA PIEZA - PIECE MEASURES:  
---

DIMENSIONES DEL EMBALAJE - PACKAGING MEASURES:  
Anchura - Width: 24,5 cm  
Altura - Height: 20 cm  
Fondo - Depth: 0,15 cm  
PESO - WEIGHT:  
---

MONOGRÁFICO

COLECCIONES - COLLECTIONS:

ARMONY, COSMOS, ELEKTRA, SEASTONE.



DIMENSIONES - MEASURES:  
Anchura - Width: 34,5 cm  
Altura - Height: 34,5 cm  
Fondo - Depth: 2,8 cm  
ACABADO - FINISH: Mate - Matt

CAPACIDAD - CAPACITY: 1-8 Piezas - Pieces  
DIMENSIONES DE LA PIEZA - PIECE MEASURES:  
Varios formatos | Several formats

DIMENSIONES DEL EMBALAJE - PACKAGING MEASURES:  
Anchura - Width: 34,5 cm  
Altura - Height: 34,5 cm  
Fondo - Depth: 2,8 cm  
PESO - WEIGHT:  
Según colección | Depending on collection

CARPETA TÉCNICA (GENÉRICA)

COLECCIONES - COLLECTIONS:

Todas las colecciones bajo pedido comercial. / All collections available upon request.

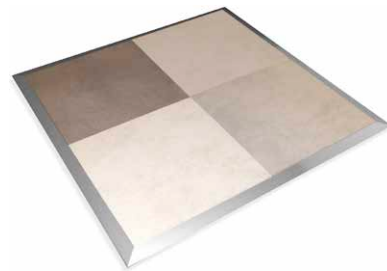

DIMENSIONES - MEASURES: Según proyecto | According to the project  
ACABADO - FINISH: Plata - Silver  
CAPACIDAD - CAPACITY: Según formato | Depending on format  
DIMENSIONES DEL EMBALAJE - PACKAGING MEASURES: Según proyecto | According to the project  
PESO - WEIGHT: Según formato | Depending on format

ALFOMBRA



SISTEMA EXPOSITIVO DINAMIC

Este sistema expositivo se diseña según proyecto.  
This exhibition system is designed according to the project.



SIL PIEZAS

Este sistema expositivo se diseña según proyecto.  
This exhibition system is designed according to the project.

CUNAS | CRADLES



DIMENSIONES DE LA CUNA - CRADLE MEASURES:  
Anchura - Width: 68 cm  
Altura - Height: 149,5 cm  
Fondo - Depth: 156,5 a-to 280 cm  
ACABADO - FINISH: Blanco - White

CAPACIDAD - CAPACITY: 10 Piezas - Pieces  
DIMENSIONES DE LA PIEZA - PIECE MEASURES:  
Anchura - Width: 120 cm | Altura - Height: 120 cm

DIMENSIONES DEL EMBALAJE - PACKAGING MEASURES:  
Anchura - Width: 160 cm  
Altura - Height: 100 cm  
Fondo - Depth: 70 cm  
PESO - WEIGHT: 120 kg

120x120 GIRATORIA



DIMENSIONES DE LA CUNA - CRADLE MEASURES:  
Anchura - Width: 85 cm  
Altura - Height: 120 cm  
Fondo - Depth: 130 a-to 200 cm  
ACABADO - FINISH: Blanco - White

CAPACIDAD - CAPACITY: 10 Piezas - Pieces  
DIMENSIONES DE LA PIEZA - PIECE MEASURES:  
Anchura - Width: 90 cm | Altura - Height: 90 cm

DIMENSIONES DEL EMBALAJE - PACKAGING MEASURES:  
Anchura - Width: 125 cm  
Altura - Height: 100 cm  
Fondo - Depth: 98 cm  
PESO - WEIGHT: 100 kg

90x90 GIRATORIA



DIMENSIONES DE LA CUNA - CRADLE MEASURES:  
Anchura - Width: 75 cm  
Altura - Height: 144 cm  
Fondo - Depth: 100 a-to 170 cm  
ACABADO - FINISH: Blanco - White

CAPACIDAD - CAPACITY: 10 Piezas - Pieces  
DIMENSIONES DE LA PIEZA - PIECE MEASURES:  
Anchura - Width: 60 cm | Altura - Height: 120 cm

DIMENSIONES DEL EMBALAJE - PACKAGING MEASURES:  
Anchura - Width: 157 cm  
Altura - Height: 65 cm  
Fondo - Depth: 98 cm  
PESO - WEIGHT: 100 kg

60x120 GIRATORIA



DIMENSIONES DE LA CUNA - CRADLE MEASURES:  
Anchura - Width: 46 cm  
Altura - Height: 100 cm  
Fondo - Depth: 95 cm  
ACABADO - FINISH: Blanco - White

CAPACIDAD - CAPACITY: 8 Piezas - Pieces  
DIMENSIONES DE LA PIEZA - PIECE MEASURES:  
Anchura - Width: 90 cm | Altura - Height: 90 cm

DIMENSIONES DEL EMBALAJE - PACKAGING MEASURES:  
Anchura - Width: 48 cm  
Altura - Height: 35 cm  
Fondo - Depth: 92 cm  
PESO - WEIGHT: 35 kg

9090 GUÍAS



DIMENSIONES DE LA CUNA - CRADLE MEASURES:  
Anchura - Width: 40 cm  
Altura - Height: 20 cm  
Fondo - Depth: 52 cm  
ACABADO - FINISH: Negro - Black

CAPACIDAD - CAPACITY: 4 Piezas - Pieces  
DIMENSIONES DE LA PIEZA - PIECE MEASURES:  
Anchura - Width: 90 cm | Altura - Height: 90 cm

DIMENSIONES DEL EMBALAJE - PACKAGING MEASURES:  
Anchura - Width: 42 cm  
Altura - Height: 15 cm  
Fondo - Depth: 55 cm  
PESO - WEIGHT: 8 kg

PEINE 90x90



DIMENSIONES DE LA CUNA - CRADLE MEASURES:  
Anchura - Width: 120 cm  
Altura - Height: 52 cm  
Fondo - Depth: 45 cm  
ACABADO - FINISH: Negro + Rojo - Black + Red

CAPACIDAD - CAPACITY: 10 Piezas - Pieces  
DIMENSIONES DE LA PIEZA - PIECE MEASURES:  
Anchura - Width: 45 a-to 60 cm | Altura - Height: 90 a-to 120 cm

DIMENSIONES DEL EMBALAJE - PACKAGING MEASURES:  
Anchura - Width: 130 cm  
Altura - Height: 15 cm  
Fondo - Depth: 60 cm  
PESO - WEIGHT: 15 kg

GRANDES FORMATOS



DIMENSIONES DE LA CUNA - CRADLE MEASURES:  
Anchura - Width: 60 cm  
Altura - Height: 177,5 cm  
Fondo - Depth: 60 cm  
ACABADO - FINISH: Negro - Black

CAPACIDAD - CAPACITY: 6 Piezas - Pieces  
DIMENSIONES DE LA PIEZA - PIECE MEASURES:  
Anchura - Width: 120 cm | Altura - Height: 60 cm

DIMENSIONES DEL EMBALAJE - PACKAGING MEASURES:  
Anchura - Width: 83 cm  
Altura - Height: 10,5 cm  
Fondo - Depth: 178 cm  
PESO - WEIGHT: 30 kg

60x120 INCLINADA



DIMENSIONES DE LA CUNA - CRADLE MEASURES:  
Anchura - Width: 42 cm  
Altura - Height: 176 cm  
Fondo - Depth: 60 cm  
ACABADO - FINISH: Blanco - White

CAPACIDAD - CAPACITY: 15 Piezas - Pieces  
DIMENSIONES DE LA PIEZA - PIECE MEASURES:  
Anchura - Width: máximo 60 cm | Altura - Height: maximum 60 cm

DIMENSIONES DEL EMBALAJE - PACKAGING MEASURES:  
Anchura - Width: 42 cm  
Altura - Height: 176 cm  
Fondo - Depth: 25 cm  
PESO - WEIGHT: 20 kg

ATRIL 15P



**CUNAS | CRADLES**



**TORRE 12P**

**DIMENSIONES DE LA CUNA - CRADLE MEASURES:**  
Anchura - Width: 45 cm  
Altura - Height: 166 cm  
Fondo - Depth: 85 cm  
ACABADO - FINISH: Negro - Black

**CAPACIDAD - CAPACITY:** 12 Piezas - Pieces  
**DIMENSIONES DE LA PIEZA - PIECE MEASURES:**  
Varios formatos | Several formats

**DIMENSIONES DEL EMBALAJE - PACKAGING MEASURES:**  
Anchura - Width: 120 cm  
Altura - Height: 15 cm  
Fondo - Depth: 45 cm  
PESO - WEIGHT: 12 kg



**PAVIMENTOS**

**DIMENSIONES DE LA CUNA - CRADLE MEASURES:**  
Anchura - Width: 60 cm  
Altura - Height: 195 cm  
Fondo - Depth: 100 cm  
ACABADO - FINISH: Negro - Black

**CAPACIDAD - CAPACITY:** 12 Piezas - Pieces  
**DIMENSIONES DE LA PIEZA - PIECE MEASURES:**  
Varios formatos | Several formats

**DIMENSIONES DEL EMBALAJE - PACKAGING MEASURES:**  
Anchura - Width: 180 cm  
Altura - Height: 110 cm  
Fondo - Depth: 60 cm  
PESO - WEIGHT: 40 kg



**CUNA ONZA AURA**

**DIMENSIONES DE LA CUNA - CRADLE MEASURES:**  
Anchura - Width: 36 cm  
Altura - Height: 40 cm  
Fondo - Depth: 20 cm  
ACABADO - FINISH: Blanco - White

**CAPACIDAD - CAPACITY:** 9 Piezas - Pieces  
**DIMENSIONES DE LA PIEZA - PIECE MEASURES:**  
Anchura - Width: 6,2 cm | Altura - Height: 25 cm

**DIMENSIONES DEL EMBALAJE - PACKAGING MEASURES:**  
Anchura - Width: 25 cm  
Altura - Height: 10 cm  
Fondo - Depth: 45 cm  
PESO - WEIGHT: 1 kg aprox.



**CUNA ONZA ESSENZA**

**DIMENSIONES DE LA CUNA - CRADLE MEASURES:**  
Anchura - Width: 40 cm  
Altura - Height: 30 cm  
Fondo - Depth: 25 cm  
ACABADO - FINISH: Blanco - White

**CAPACIDAD - CAPACITY:** 8 Piezas - Pieces  
**DIMENSIONES DE LA PIEZA - PIECE MEASURES:**  
Anchura - Width: 15 cm | Altura - Height: 15 cm

**DIMENSIONES DEL EMBALAJE - PACKAGING MEASURES:**  
Anchura - Width: 35 cm  
Altura - Height: 10 cm  
Fondo - Depth: 45 cm  
PESO - WEIGHT: 1 kg aprox.



**30x90**

**DIMENSIONES DE LA CUNA - CRADLE MEASURES:**  
Anchura - Width: 30 cm  
Altura - Height: 25 cm  
Fondo - Depth: 55 cm  
ACABADO - FINISH: Negro - Black

**CAPACIDAD - CAPACITY:** 6 Piezas - Pieces  
**DIMENSIONES DE LA PIEZA - PIECE MEASURES:**  
Anchura - Width: 30 cm | Altura - Height: 90 cm

**DIMENSIONES DEL EMBALAJE - PACKAGING MEASURES:**  
Anchura - Width: 32 cm  
Altura - Height: 7 cm  
Fondo - Depth: 57 cm  
PESO - WEIGHT: 10 kg



**PEINE 8P**

**DIMENSIONES DE LA CUNA - CRADLE MEASURES:**  
Anchura - Width: 50 cm  
Altura - Height: 25 cm  
Fondo - Depth: 58 cm  
ACABADO - FINISH: Blanco - White

**CAPACIDAD - CAPACITY:** 8 Piezas - Pieces  
**DIMENSIONES DE LA PIEZA - PIECE MEASURES:**  
Todos los formatos | All formats

**DIMENSIONES DEL EMBALAJE - PACKAGING MEASURES:**  
Anchura - Width: 51 cm  
Altura - Height: 7 cm  
Fondo - Depth: 61 cm  
PESO - WEIGHT: 9,5 kg



**PEINE 6P**

**DIMENSIONES DE LA CUNA - CRADLE MEASURES:**  
Anchura - Width: 60 cm  
Altura - Height: 6 cm  
Fondo - Depth: 65 cm  
ACABADO - FINISH: Negro - Black

**CAPACIDAD - CAPACITY:** 6 Piezas - Pieces  
**DIMENSIONES DE LA PIEZA - PIECE MEASURES:**  
Todos los formatos | All formats

**DIMENSIONES DEL EMBALAJE - PACKAGING MEASURES:**  
Anchura - Width: 65 cm  
Altura - Height: 10 cm  
Fondo - Depth: 70 cm  
PESO - WEIGHT: 8 kg



**40x120**

**DIMENSIONES DE LA CUNA - CRADLE MEASURES:**  
Anchura - Width: 50 cm  
Altura - Height: 163 cm  
Fondo - Depth: 67 cm  
ACABADO - FINISH: Negro - Black

**CAPACIDAD - CAPACITY:** 8 Paneles - Panels  
**DIMENSIONES DEL PANEL - PANEL MEASURES:**  
Anchura - Width: 47 cm | Altura - Height: 150 cm

**DIMENSIONES DEL EMBALAJE - PACKAGING MEASURES:**  
Anchura - Width: 51 cm  
Altura - Height: 6,1 cm  
Fondo - Depth: 164,1 cm  
PESO - WEIGHT: 21 kg



**PEINE PLAFONES**

**DIMENSIONES DE LA CUNA - CRADLE MEASURES:**  
Anchura - Width: 60 cm  
Altura - Height: 120 cm  
Fondo - Depth: 65 cm  
ACABADO - FINISH: Antracita - Antracite

**CAPACIDAD - CAPACITY:** 6 Paneles - Panels  
**DIMENSIONES DEL PANEL - PANEL MEASURES:**  
Anchura - Width: 50 cm | Altura - Height: 120 cm

**DIMENSIONES DEL EMBALAJE - PACKAGING MEASURES:**  
Anchura - Width: 120 cm  
Altura - Height: 40 cm  
Fondo - Depth: 80 cm  
PESO - WEIGHT: 50 kg



**PORTA-PLAFONES**

**DIMENSIONES DE LA CUNA - CRADLE MEASURES:**  
Anchura - Width: 40,2 cm  
Altura - Height: 70 cm  
Fondo - Depth: 80 cm  
ACABADO - FINISH: Negro + Rojo - Black + Red

**CAPACIDAD - CAPACITY:** 25 Plafones - Plafons  
**DIMENSIONES DEL PLAFON - PLAFONS MEASURES:**  
Todos los formatos | All formats

**DIMENSIONES DEL EMBALAJE - PACKAGING MEASURES:**  
Anchura - Width: 80 cm  
Altura - Height: 10,4 cm  
Fondo - Depth: 70 cm  
PESO - WEIGHT: 10 kg





**AZTECA PRODUCTS & SERVICES S.L.U.**  
Ctra. Castellón-Alcora, Km 19,7  
12110 Alcora (Castellón-Spain)  
Tel. (+34) 964 367 500  
comercial@azteca.es



